

# Block B: Fuel Gas Systems



# Block B: Fuel Gas Systems

Plumbing Apprenticeship Program Level 4

SkilledTradesBC

BCCAMPUS  
VICTORIA, B.C.



*Block B: Fuel Gas Systems* Copyright © 2025 by SkilledTradesBC is licensed under a [Creative Commons Attribution-NonCommercial-ShareAlike 4.0 International License](https://creativecommons.org/licenses/by-nc-sa/4.0/), except where otherwise noted.

© 2025 SkilledTradesBC

The CC licence permits you to retain, reuse, copy, redistribute, and revise this book—in whole or in part—for free providing it is for non-commercial purposes, and adapted and reshared content retains the same licence, and the author is attributed as follows:

[Block B: Fuel Gas Systems](#) by SkilledTradesBC is licensed under a [CC BY-NC-SA 4.0 licence](https://creativecommons.org/licenses/by-nc-sa/4.0/).

If you redistribute all or part of this book, it is recommended the following statement be added to the copyright page so readers can access the original book at no cost:

Download for free from the [B.C. Open Collection](#).

**Sample APA-style citation (7th Edition):**

SkilledTradesBC. (2025). *Block B: Fuel gas systems*. BCcampus. <https://opentextbc.ca/plumbing4b/>

**Cover image attribution:**

["Oil and Gas 11"](#) by [Matthew Dance](#) is licensed under a [CC BY-NC-SA 2.0 licence](https://creativecommons.org/licenses/by-nc-sa/2.0/).

**Ebook ISBN:** 978-1-77420-267-8

**Print ISBN:** 978-1-77420-266-1

Visit [BCCampus Open Education](https://bccampusopeneducation.ca/) to learn about open education in British Columbia.

This book was produced with Pressbooks (<https://pressbooks.com>) and rendered with Prince.

# Contents

Accessibility Statement	1
For Students: How to Access and Use this Textbook	5
About BCcampus Open Education	vii

## Competency B1: Select Regulators, Valves, and Valve Train Components

Learning Task 1	11
Describe Manual Valves	
Learning Task 2	23
Describe Gas Valve Train	
Learning Task 3	27
Describe Pressure Regulators	
Learning Task 4	55
Describe Automatic Gas Valves	

## Competency B2: Install Regulators, Valves, and Valve Train Components

Learning Task 1	109
Installing Manual Valves	
Learning Task 2	117
Installing Gas Pressure Regulators	

## Competency B3: Commission Fuel Gas Delivery Systems

Learning Task 1	135
Describe Gas Piping and Tubing Pressure Testing	
Learning Task 2	143
Purging Low Volume Gas Piping Systems	

## Competency B4: Install Air Supply Systems for Fuel Gas Appliances

Learning Task 1	151
Describe The Methods of Providing Gas Appliance Air Supply	
Learning Task 2	157
Code Requirements For Gas Appliance Air Supply	

Learning Task 3	175
Describe The Installation of Passive Air Supply Systems	
Appendix 1: Self-Tests	185
Appendix 2: Self-Test Answer Keys	209
Versioning History	213

## Accessibility Statement

BCcampus Open Education believes that education must be available to everyone. This means supporting the creation of free, open, and accessible educational resources. We are actively committed to increasing the accessibility and usability of the textbooks we produce.

### Accessibility of This Resource

BCcampus was requested to make this resource available to students starting in January 2025 and, as a result, we are making this book public before all of our production work is finished, namely image descriptions and attributions. Due to this, this book does not meet our accessibility standards at the time of publication. We will be continuing to work on these steps after the book has been made public and these issues will be resolved at a later date.

In the mean time, we have done our best to be transparent about the existing accessibility barriers and features below:

### Accessibility Checklist

<b>Element</b>	<b>Requirements</b>	<b>Pass?</b>
<b>Headings</b>	Content is organized under headings and subheadings that are used sequentially.	Yes
<b>Images</b>	Images that convey information include alternative text descriptions. These descriptions are provided in the alt text field, in the surrounding text, or linked to as a long description.	Yes
<b>Images</b>	Images and text do not rely on colour to convey information.	Yes
<b>Images</b>	Images that are purely decorative or are already described in the surrounding text contain empty alternative text descriptions. (Descriptive text is unnecessary if the image doesn't convey contextual content information.)	Yes
<b>Tables</b>	Tables include row and/or column headers that have the correct scope assigned.	Yes
<b>Tables</b>	Tables include a title or caption.	Yes
<b>Tables</b>	Tables do not have merged or split cells.	Yes
<b>Tables</b>	Tables have adequate cell padding.	Yes
<b>Links</b>	The link text describes the destination of the link.	Yes
<b>Links</b>	Links do not open new windows or tabs. If they do, a textual reference is included in the link text.	Yes
<b>Links</b>	Links to files include the file type in the link text.	Yes
<b>Audio</b>	All audio content includes a transcript that includes all speech content and relevant descriptions of non-speech audio and speaker names/headings where necessary.	N/A
<b>Video</b>	All videos include high-quality (i.e., not machine generated) captions of all speech content and relevant non-speech content.	N/A
<b>Video</b>	All videos with contextual visuals (graphs, charts, etc.) are described audibly in the video.	Yes
<b>H5P</b>	All H5P activities have been tested for accessibility by the H5P team and have passed their testing.	Yes
<b>H5P</b>	All H5P activities that include images, videos, and/or audio content meet the accessibility requirements for those media types.	N/A
<b>Formulas</b>	Formulas have been created using LaTeX and are rendered with MathJax.	Yes
<b>Formulas</b>	If LaTeX is not an option, formulas are images with alternative text descriptions.	N/A
<b>Font</b>	Font size is 12 point or higher for body text.	Yes
<b>Font</b>	Font size is 9 point for footnotes or endnotes.	Yes
<b>Font</b>	Font size can be zoomed to 200% in the webbook or eBook formats.	Yes

### Let Us Know if You are Having Problems Accessing This Book

We are always looking for ways to make our resources more accessible. If you have problems accessing this resource, please contact us to let us know so we can fix the issue.

Please include the following information:

- The name of the resource
- The location of the problem by providing a web address or page description.
- A description of the problem
- The computer, software, browser, and any assistive technology you are using that can help us diagnose and solve your issue (e.g., Windows 10, Google Chrome (Version 65.0.3325.181), NVDA screen reader)

You can contact us one of the following ways:

- Web form: [BCcampus Open Ed Help](#)
- Web form: [Report an Error](#)

This statement was last updated on May 5th, 2025.

The Accessibility Checklist table was adapted from one originally created by the [Rebus Community](#) and shared under a [CC BY 4.0 License](#).



## For Students: How to Access and Use this Textbook

This textbook is available in the following formats:

- **Online webbook.** You can read this textbook online on a computer or mobile device in one of the following browsers: Chrome, Firefox, Edge, and Safari.
- **PDF.** You can download this book as a PDF to read on a computer (Digital PDF) or print it out (Print PDF).
- **Mobile.** If you want to read this textbook on your phone or tablet, you can use the EPUB (eReader) file.
- **HTML.** An HTML file can be opened in a browser. It has very little style so it doesn't look very nice, but some people might find it useful.

For more information about the accessibility of this textbook, see the Accessibility Statement.

You can access the online webbook and download any of the formats for free here: [Block B: Fuel Gas Systems](#). To download the book in a different format, look for the “Download this book” drop-down menu and select the file type you want.

### How can I use the different formats?

Format	Internet required?	Device	Required apps	Accessibility Features	Screen reader compatible
Online webbook	Yes	Computer, tablet, phone	An Internet browser (Chrome, Firefox, Edge, or Safari)	WCAG 2.0 AA compliant, option to enlarge text, and compatible with browser text-to-speech tools	Yes
PDF	No	Computer, print copy	Adobe Reader (for reading on a computer) or a printer	Ability to highlight and annotate the text. If reading on the computer, you can zoom in.	Unsure
EPUB	No	Computer, tablet, phone	An eReader app	Option to enlarge text, change font style, size, and colour.	Unsure
HTML	No	Computer, tablet, phone	An Internet browser (Chrome, Firefox, Edge, or Safari)	WCAG 2.0 AA compliant and compatible with browser text-to-speech tools.	Yes

### Tips for Using This Textbook

- **Search the textbook.**

- If using the online webbook, you can use the search bar in the top right corner to search the entire book for a key word or phrase. To search a specific chapter, open that chapter and use your browser’s search feature by hitting **[Cntr] + [f]** on your keyboard if using a Windows computer or **[Command] + [f]** if using a Mac computer.
- The **[Cntr] + [f]** and **[Command] + [f]** keys will also allow you to search a PDF, HTML, and EPUB files if you are reading them on a computer.
- If using an eBook app to read this textbook, the app should have a built-in search tool.
- **Navigate the textbook.**
  - This textbook has a table of contents to help you navigate through the book easier. If using the online webbook, you can find the full table of contents on the book’s homepage or by selecting “Contents” from the top menu when you are in a chapter.
- **Annotate the textbook.**
  - If you like to highlight or write on your textbooks, you can do that by getting a print copy, using the Digital PDF in Adobe Reader, or using the highlighting tools in eReader apps.

## Webbook vs. All Other Formats

The webbook includes H5P Interactive Activities. If you are not using the webbook to access this textbook, this content will not be included. Instead, your copy of the text will provided a link to where you can access that content online.

However, the interactive activities are also provided in alternate formats for people not using the webbook. Those questions have been made available in a static format in [Appendix 1: Self-Tests](#) and the answers are available in [Appendix 2: Self-Test Answer Keys](#).

Even if you decide to use a PDF or a print copy to access the textbook, you can access the webbook and download any other formats at any time.

---

## About BCcampus Open Education

*Block B: Fuel Gas Systems* by SkilledTradesBC was funded by BCcampus Open Education.

[BCcampus Open Education](#) began in 2012 as the B.C. Open Textbook Project with the goal of making post-secondary education in British Columbia more accessible by reducing students' costs through the use of open textbooks and other OER. [BCcampus](#) supports the post-secondary institutions of British Columbia as they adapt and evolve their teaching and learning practices to enable powerful learning opportunities for the students of B.C. BCcampus Open Education is funded by the [Ministry of Post-Secondary Education and Future Skills](#) and the [Hewlett Foundation](#).

Open educational resources (OER) are teaching, learning, and research resources that, through permissions granted by the copyright holder, allow others to use, distribute, keep, or make changes to them. Our open textbooks are openly licensed using a [Creative Commons licence](#) and are offered in various eBook formats free of charge, or as printed books that are available at cost.

For more information about open education in British Columbia, please visit the [BCcampus Open Education](#) website. If you are an instructor who is using this book for a course, please fill out our [Adoption of an Open Textbook](#) form.

This book was produced using the following styles: [Plumbing Level 4 Series Style Sheet \[Word file\]](#)



# Competency B1: Select Regulators, Valves, and Valve Train Components

Valves are devices by which the flow of a fluid can be started, stopped, or regulated by a movable part that opens or obstructs passage. Gas valves control the flow of gas at various points along the gas piping system. There are a series of valves and components located on the appliance gas supply known as the valve train. The valve train is used to manually and automatically start, stop and regulate the gas flow to the appliance as needed. In this competency you will look at the purpose of each of these components as well as the variety of valves.

## Learning Objectives

After completing the learning tasks in this competency, you will be able to:

- Select valves
- Describe the gas valve trains for appliances rated at 400 MBH or less.
- Describe the purpose and operation of gas pressure regulators
- Describe the purpose and operation of automatic gas valves



---

## Learning Task 1

### Describe Manual Valves

Manual gas valves are incorporated into the piping system in different ways to provide a method of ensuring that the gas has been positively turned off to an area of the piping system or to a particular appliance. The gas fitter will need to select the correct valve for the job to be done. The gas codes will specify particular locations and applications that require the installations of manual gas valves.

For example, the CSA B149.1 Installation Code clearly requires that a readily accessible gas shut-off valve for each appliance be installed. This manual appliance shut-off valve is typically located just outside of the appliance, where it can be easily reached, to enable the gasfitter to isolate the appliance to perform any necessary repairs or service.

### Types of Manual Gas Valves

Most gas shut-off applications will require the use of a manual valve that will fully open or close with a quarter-turn of the handle. Ball valves and lubricated plug valves are the most common, but eccentric types are also used on larger pipelines. Globe, butterfly, and needle types are also used for throttling applications.

### Valve ratings

All gas valves must be used within their certified pressure and temperature rating range. The gas installation code recognizes a number of different certification organizations and standards for manual shut-off valves. The markings on the gas valve and or the manufactures specification can be checked to verify the intended purpose for the valve. The multiple approvals that are typically found on each valve can become confusing, as the manufacture attempts to mark all the associated certifications onto the valve body and or handle (Figure 1).

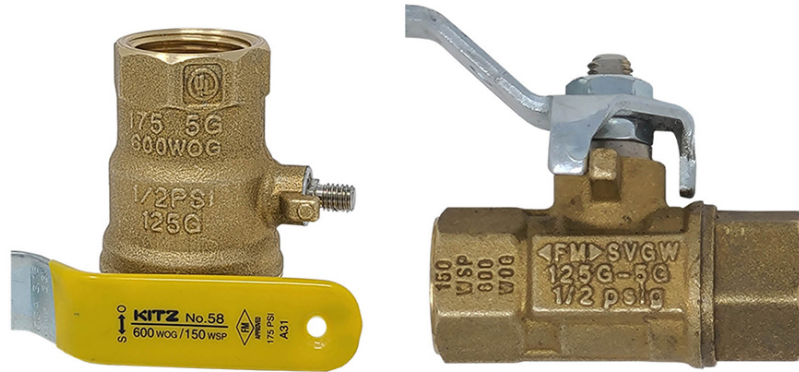

Figure 1. Valve markings

Common pressure class or rating markings that are found on gas valves include:

- WOG stands for Water, Oil and Gas and CWP stands for Cold Working Pressure. They both refer to the non-shock pressure rating for valves at an ambient temperature up to 380 C. Water is straightforward but the oil and gas parts are a little more complicated. “Gas” references air, nitrogen etc. but does not cover combustible gases. There are more specific approvals required for fuel gas applications.
- WSP stands for Working Steam Pressure and defines the pressure of steam in a system that a valve can be used in. The industry uses WSP for bronze ball valves because, as the temperature rises, the strength of the material decreases.
- G is for combustible gases, as not all valves are certified for use on fuel gas applications. Valves that are certified for combustible gas applications will have some or all of the following specific markings:
  - ½ PSIG (or ½ G) – a lower pressure rating for gas valves generally used at a gas fired appliance.
  - 5G – a higher pressure rating for gas valves generally used indoor and out in Canada on gas piping distribution systems.
  - 125G – a USA gas pressure rating of 125 PSIG for use in gas piping systems.
  - CAN/CGA-3.16 – a Canadian gas pressure rating of 125 PSIG for outdoor use in gas piping systems

The most common certification organizations abbreviations that appear on valves to identify their rating are:

- UL – Underwriter’s Laboratories tests valves to 3 times the pressure rating stated on the valve body. These valves must pass UL’s test in order to have the UL logo on the valve body.
- CSA – Canadian Standards Association is another organization that tests valves to ensure they meet their standards. Even though this is a Canadian association, it does tests for both Canadian and US standards. A “C” or “US” may be found under their logo indicating which

country's standards the valve has been tested to. If both appear, the valve has been tested to the highest standard in both countries.

- CGA – Compressed Gas Association develops standards for the industrial, medical, and food gases industry
- <FM> – Factory Mutual Global, a US based insurance company, has approved the valve. They take an engineering approach to make sure the valve meets their high standards.
- UPC / cUPC – Uniform Plumbing Code (UPC) and Canadian Uniform Plumbing Code (cUPC) ensure that plumbing products are safe and sanitary.
- ANSI – American National Standards Institute tests valves to various standards.

## Ball valves

The lever operated non-lubricated ball valve is the most common valve used for appliance shut-off. For residential and commercial applications, they are usually constructed of a brass (BRS) body with a chrome plated brass ball. Teflon seats and packing are most common but smaller sizes may use O-rings (Figure 2).

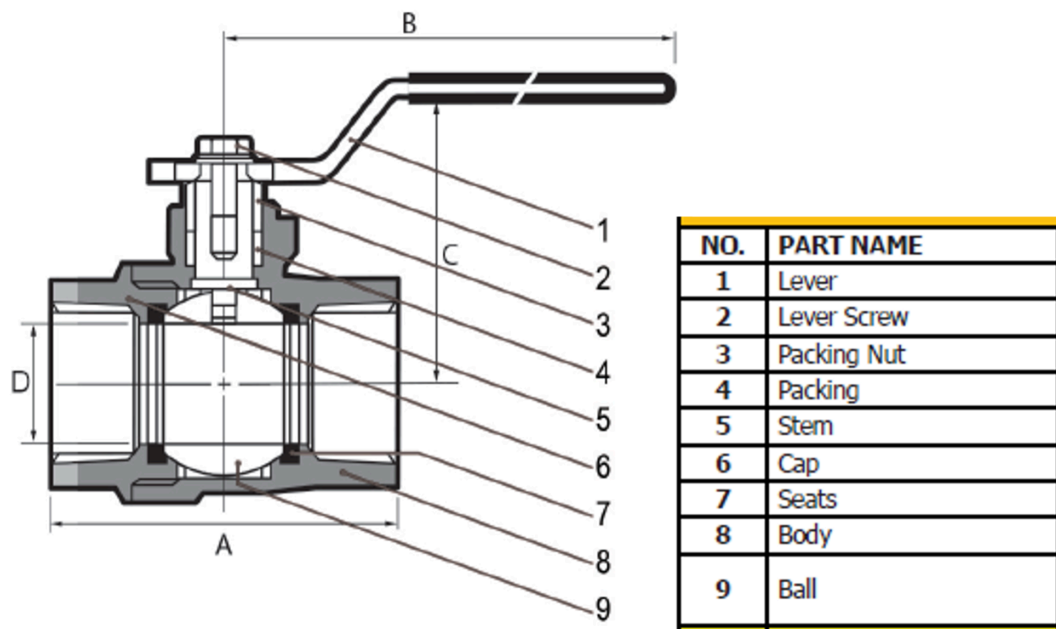

Figure 2. Cross section of lever operated ball valve [\[Image Description\]](#)

The ball has a hole drilled through its center. With the handle in the open position, (aligned with the valve) the hole is aligned with the connection openings in the valve body and flow is permitted. When the valve is closed both the handle and hole are positioned perpendicularly to the valve body and flow is stopped (Figure 3).

14 Competency B1: Select Regulators, Valves, and Valve Train Components

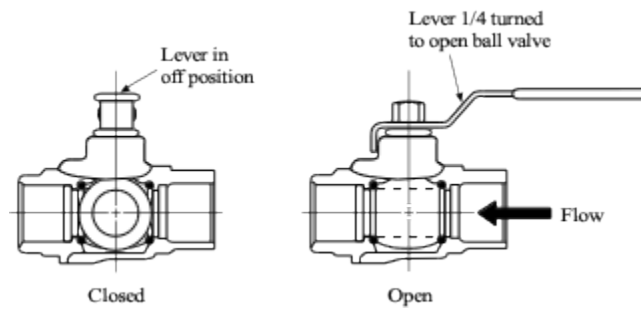

Figure 3. Manual ball valve operation

The valves are often constructed with a two-piece body in which the two threaded halves hold the ball and seats in place. Smaller valves may be of a one-piece body design, which use a retaining clip and washer to hold the ball and seats in place (Figure 4).

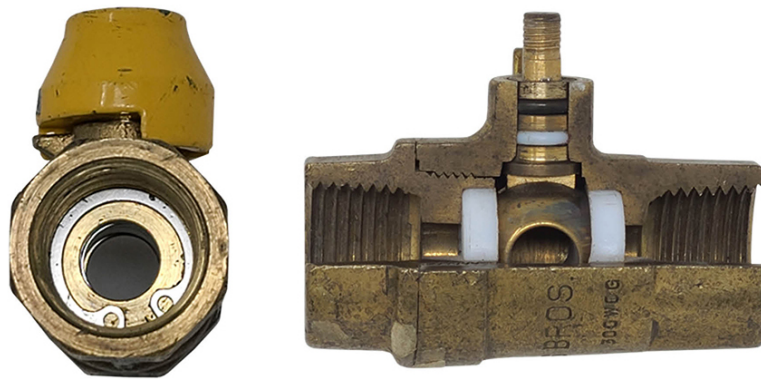

Figure 4. two-piece valve (left). One-piece valve (right)

The size of the hole or port in the ball may vary. A full port ball valve has the same internal hole size as the nominal pipe size connections. A reduced port ball valve, also known as a standard port ball valve, has an opening through the ball that is one pipe size smaller than the valve's nominal pipe size connection (Figure 5).

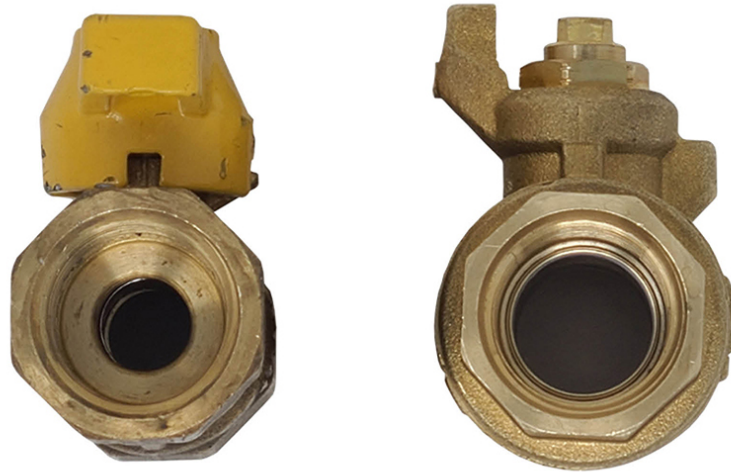

Figure 5. Reduced port (left). Full port (right)

### Handle types

Ball valves are available with various handle styles and colours. Gas valve are available with different types of handle including steel, aluminum or wing handles (Figure 6). While gas valve handles are often coloured yellow, you will also find gas rated ball valves in other colours such as red, blue and green. Some handles are designed so they can be used to lock the valve position, by removing and reinstalling the handle so the notch holds the valve in the closed locked position.

### End connections

Brass ball valves under NPS 2" are most commonly supplied with internal threads (FNPT) or male flared end connections, or a combination of both (Figure 6).

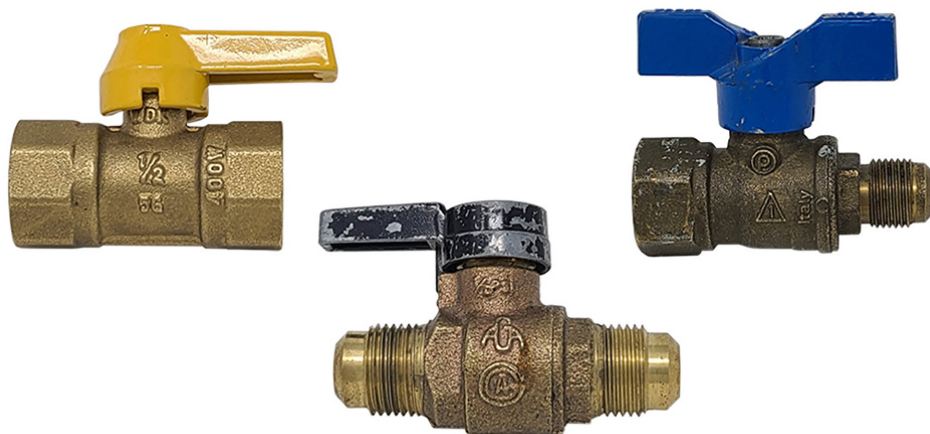

Figure 6. Ball valve end connections

## Plug valves

Plug valves are another type of manual shut off used in gas systems. They also fully open or close with a quarter turn of the handle. They use a tapered, drilled “plug” as their isolating component instead of a ball. Brass spring loaded versions were used in the past for indoor, low pressure applications (Figure 7) but are no longer manufactured.



*Figure 7. Spring loaded gas valve*

The lubricated type of plug valve is approved for indoor or outdoor use and is common on exterior gas meter installations. It is often called a Luboseal™ gas valve after one of the most popular brand names. The tapered plug has O-rings at the top and bottom so that a film of lubricating sealant is maintained between the internal surfaces of the plug and matching body (Figure 8).

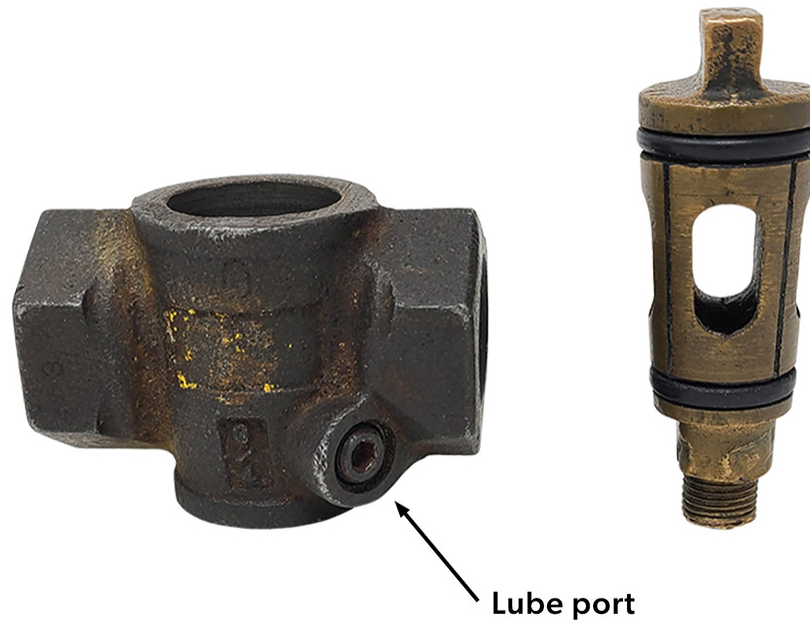

*Figure 8. Lubricated plug valve*

The lubrication helps ensure a gas tight seal and provides easier turning of the plug in the body. Machined grooves and passages enable the valve to be relubricated and maintained with the valve in place and with no interruption of service. Lubricant is injected through a port located in the valve body (Figure 8) or top of the plug (Figure 9).

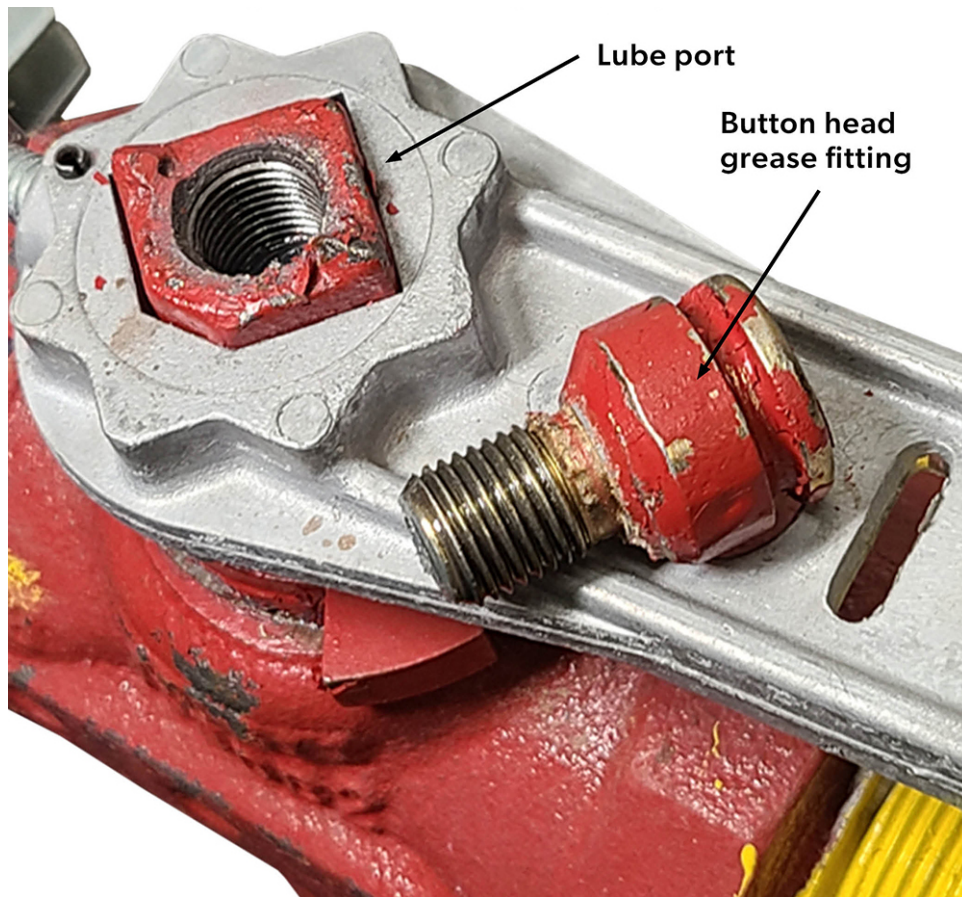

*Figure 9. Stem fitting lube plug valve*

Lubricated gas valves installed within the meter sets are maintained by the gas utility. Notice that the three gas valves shown in figure 10 are a locking type with the middle bypass valve locked in the closed position. The top red valve also has a dielectric insulated union outlet.



*Figure 10. Luboseal™ gas valves on meter set supply*

## Throttling valves

There are other manual valves that are not used for positive shut-off on fuel gas systems. They are also known as firing rate valves or limiting orifice valves in certain applications (Figure 11). For example, butterfly, globe, and needle valves are used for burner flow adjustment, but must have an approved manual shut-off valve installed upstream.



Figure 11. Globe style limiting orifice gas valve



Now complete Self-Test 1 and check your answers.

## Self-Test 1

### Self-Test 1



An interactive H5P element has been excluded from this version of the text. You can view it online here: <https://opentextbc.ca/plumbing4b/?p=5#h5p-1>

## Media Attributions

- Figure 1. “Valve markings” by Rod Lidstone is licensed under a [CC BY-NC-SA licence](#).
- Figure 2. “Cross section of lever operated ball valve” – The source for this image is unknown. It is being used for non-commercial, educational purposes. To receive credit for this image, please reach out to the publisher.
- Figure 3. “Manual ball valve operation” – The source for this image is unknown. It is being used for non-commercial, educational purposes. To receive credit for this image, please reach out to the publisher.
- Figure 4. “Two-piece valve (left). One-piece valve (right)” by Rod Lidstone is licensed under a [CC BY-NC-SA licence](#).
- Figure 5. “Reduced port (left). Full port (right)” by Rod Lidstone is licensed under a [CC BY-NC-SA licence](#).
- Figure 6. “Ball valve end connections” by Rod Lidstone is licensed under a [CC BY-NC-SA licence](#).
- Figure 7. “Spring loaded gas valve” by Rod Lidstone is licensed under a [CC BY-NC-SA licence](#).
- Figure 8. “Lubricated plug valve” by Rod Lidstone is licensed under a [CC BY-NC-SA licence](#).
- Figure 9. “Stem fitting lube plug valve” by Rod Lidstone is licensed under a [CC BY-NC-SA licence](#).
- Figure 10. “Luboseal™ gas valves on meter set supply” by Rod Lidstone is licensed under a [CC BY-NC-SA licence](#).
- Figure 11. “Globe style limiting orifice gas valve” by Rod Lidstone is licensed under a [CC BY-NC-SA licence](#).

## Image descriptions

**Figure 2. “Cross section of lever operated ball valve” image description:** A labelled diagram of a cross section of a lever-operated ball valve. It labels parts from 1 to 9 and distances from A to D.

1. Lever
2. Lever screw
3. Packing nut
4. Packing
5. Stem
6. Cap
7. Seats

22 Competency B1: Select Regulators, Valves, and Valve Train Components

- 8. Body
- 9. Ball
  
- A. Distance of bottom of valve
- B. Length of valve lever
- C. Distance from bottom of handle to middle of valve
- D. Height of valve opening [\[Return to Figure 2\]](#)

## Learning Task 2

### Describe Gas Valve Train

The series of controls and components from the appliance main shut-off valve to the appliance burner is called the valve-train or manifold assembly. The components of the valve train are used to manually and automatically start, stop and regulate the gas flow to the appliance. On larger gas appliances, generally over 400 MBH, the valve train components downstream of the manual shut-off valve (Figure 12) will be field assembled as they are not an integral part of the appliance. For these installations the requirement for valve train components and their assembly are identified in the separate CSA B149.3 gas code.

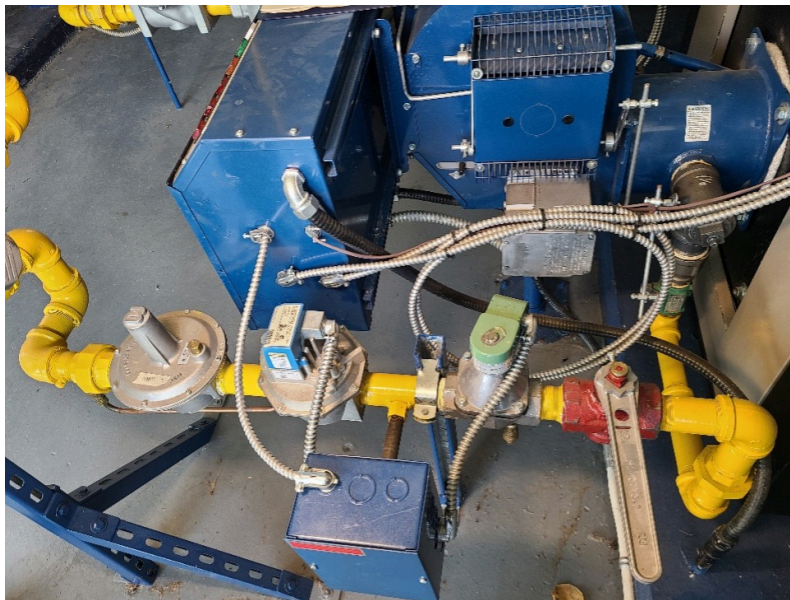

Figure 12. Field assembled valve train

For installations under 400MBH the valve train assembly is typically supplied and preassembled as part of the appliance. Although manufactures appliance valve trains will vary in how they are assembled, they will all have the components shown in Figure 13 in one form or another. This diagram is used as in introduction because it shows all of the components as separate parts, whereas on modern appliance many of these components are combined into one valve. body.

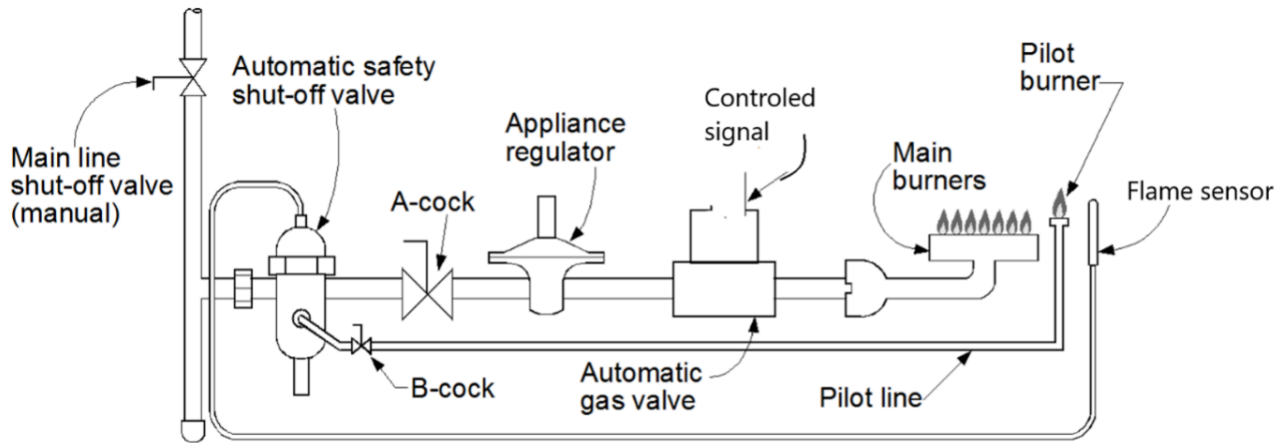

Figure 13. Valve train assembly

The valve train components from the manual shut-off valve will include:

- Automatic safety shut-off valve; will turn off all the gas to the appliance in the event of burner failure. If the automatic safety shut-off valve stops the flow of gas to both the main burner and the pilot burner it is referred to as 100% safe.
- B-cock; can be a ball valve but, is usually a needle-type valve included within a combination valve body. It is used to isolate as well as throttle the volume of flow to the pilot burner assembly in order to adjust the pilot flame.
- A-Cock; a manual shut-off valve that is used to isolate the components downstream to enable servicing while still allowing gas to flow to the pilot. It does not regulate either flow or pressure, just opens and closes the gas line.
- Appliance regulator; maintains a constant gas pressure to the burner(s) over a sometimes fluctuating gas inlet pressure and a possible modulating burner gas flow. This assures a constant, even flame at the main burners. Regulators will be looked at in greater detail in Learning Task 3.
- Automatic gas valve; a valve normally energized by a 24-volt alternating current (AC), but may be line voltage (120 V) or millivoltage (thousandths of a volt). It is usually wired in series with a sensing control (thermostat, aquastat, or pressuretrol) which automatically activates the appliance as needed. It can also be a non -electric valve activated by a mechanical heat sensing controller.



Now complete Self-Test 2 and check your answers.

## Self-Test 2

### Self-Test 2



*An interactive H5P element has been excluded from this version of the text. You can view it online here:*  
<https://opentextbc.ca/plumbing4b/?p=32#h5p-2>

## Media Attributions

- Figure 12. “Field assembled valve train” by Rod Lidstone is licensed under a [CC BY-NC-SA licence](#).
- Figure 13. “Valve train assembly” – The source for this image is unknown. It is being used for non-commercial, educational purposes. To receive credit for this image, please reach out to the publisher.



---

## Learning Task 3

### Describe Pressure Regulators

Pressures throughout the various gas piping systems varies greatly to accommodate the different system requirements and limitations. For example, the natural gas customer supply mains or propane storage containers will have high pressure to increase their volume capacity. Whereas the maximum allowable inlet pressure for gas appliances is typically only ½ psig, Pressure regulators are used throughout gas piping systems to maintain a desired reduced outlet downstream pressure while providing the required gas flow to satisfy the demand. Regulators are self-contained, self-operated control devices which use energy from the system to operate.

Other the following terms may vary in their usage for this textbook we will use the following definitions:

- **Category** – The name associated with regulators used to serve a specific purpose and or location
- **Classification or Class** – a term used to express pressure or volume limitations that may exist within a category.
- **Type** – a term used to identify various physical styles and designs. There are many regulator types that exist within a category to achieve different performance characteristics.
- **SCFH** – capacity; means standard cubic feet per hour of a gas at temperature of 70° F and a pressure of 14.7 PSIA.
- **Servo or Pilot** – a mechanism set in operation by another mechanism

### Purpose

Gas pressure regulators have two main purposes:

- To reduce the supply pressure to a safe operating pressure for the building or connected appliance(s).
- To maintain a constant downstream pressure, regardless of changes in the gas flow or upstream pressure.

The regulators downstream pressure can typically be adjusted within a certain range to match the system requirements.

Some regulators may also provide overpressure protection to prevent gas pressure in the system from exceeding the rating of the system components.

## Regulator Categories

There are four categories of pressure regulators as defined in the CSA B149.1 Natural Gas and Propane Installation Code:

- Service regulators
- Appliance regulators
- Line pressure regulators
- High pressure regulators

### Service regulators

Service regulators are installed on a service line to reduce the gas pressure to the desired building pressure. The Natural gas meter sets are provided with a service regulator (Figure 14), which is installed by the gas utility rather than the gasfitter.

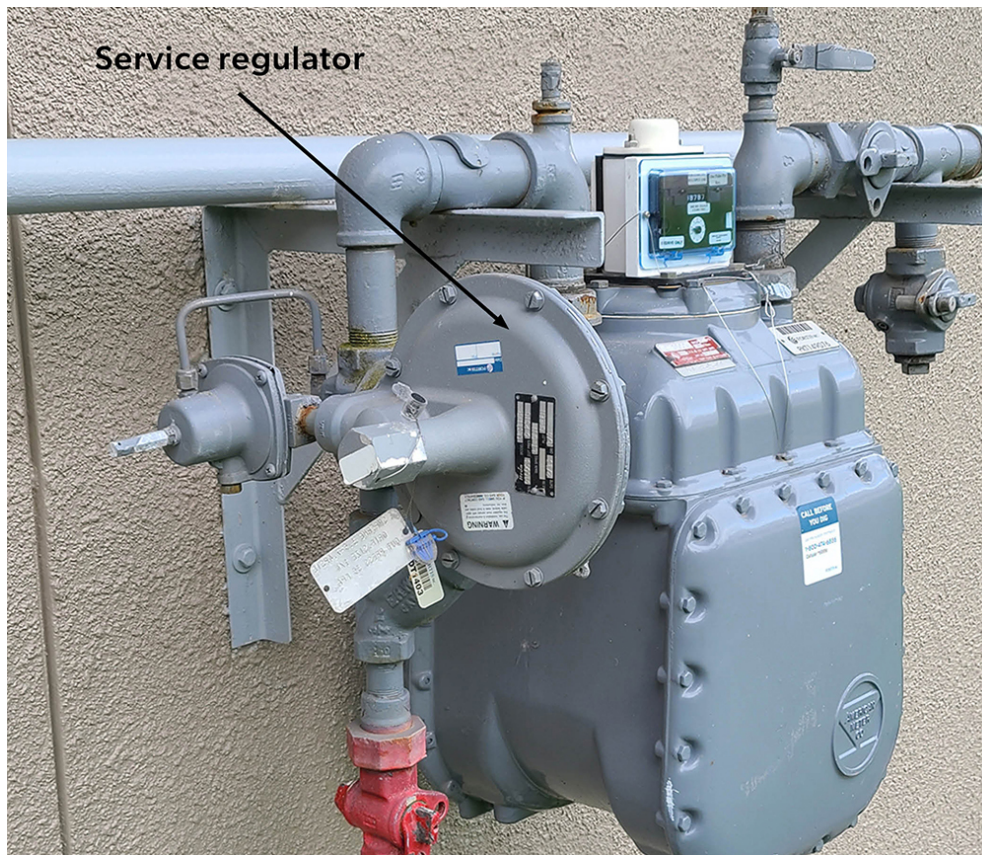

Figure 14. Natural gas meter set

For propane systems, service regulators are installed by the gas technician/fitter between the storage container and the building. Propane service regulators are also called second stage regulators or twin stage regulators (Figure 15).

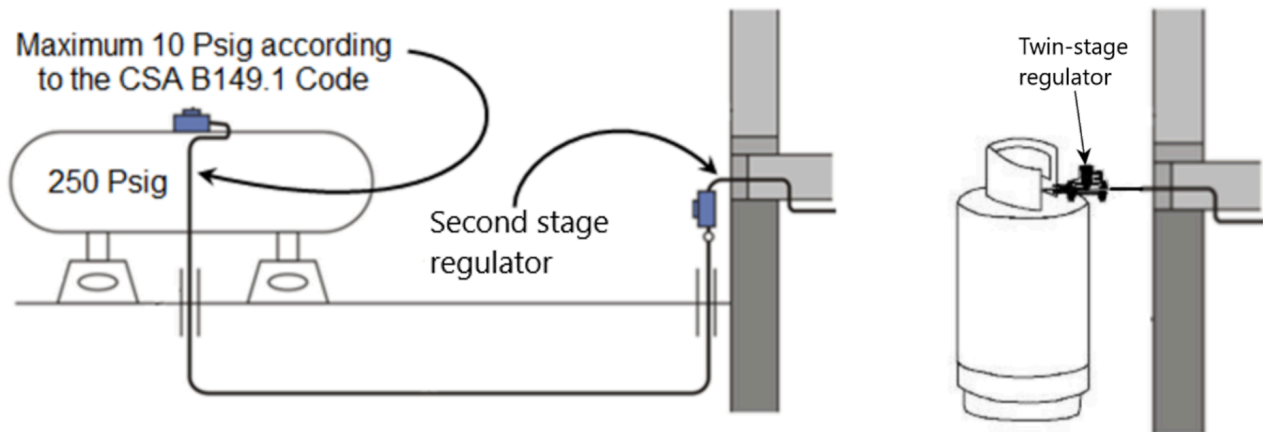

Figure 15. Propane service regulators

The maximum delivery pressures within various types of buildings are listed in section 5.1 of the CSA B149.1 gas code. For example the maximum allowed pressure in a single-family dwelling is 2 psig.

### Appliance regulators

Appliance regulators are located on the valve train of the appliance to reduce the inlet pressure of the appliance to the appropriate manifold pressure required for proper burner performance (Figure 16). The main purpose of the appliance regulator is to maintain a relatively constant gas outlet pressure to the burner(s) to assure constant, even flame at the main burners.

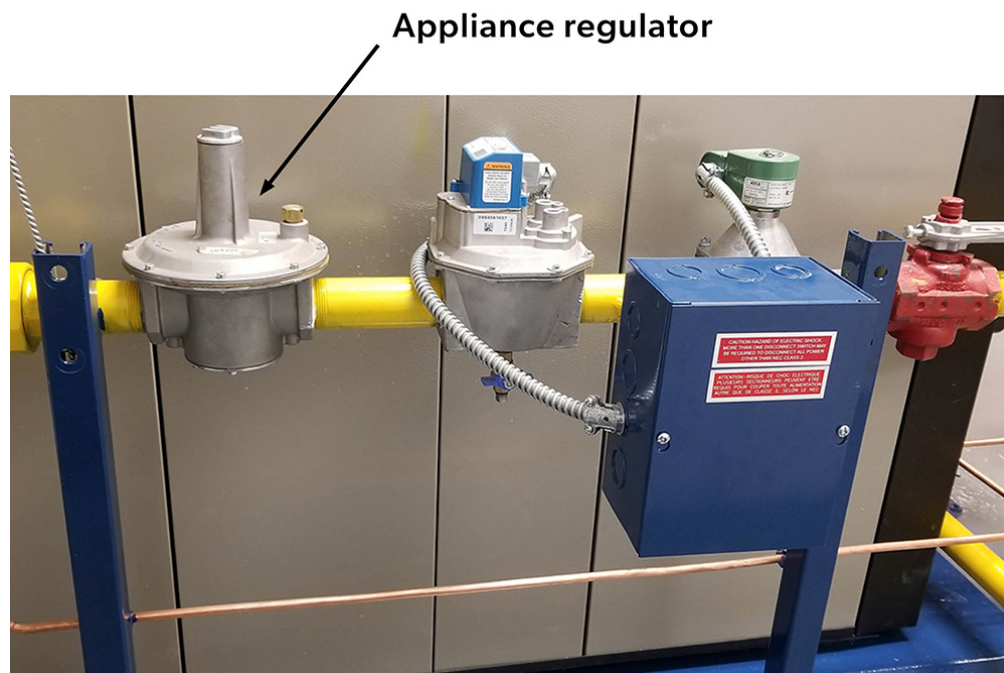

Figure 16. Appliance regulator in valve train

Most natural gas appliances require a manifold pressure of 3" to 4" WC, while propane appliances

typically require 10” to 11” WC. Residential and commercial appliances will typically have an appliance regulator with a maximum inlet pressure of 0.5 psig (14” WC).

For appliances with inputs less than 400 MBH the appliance regulator is often included as part of a combination gas valve (Figure 17). These combination valves often employ servo operated regulators that can have the manifold pressures stepped or modulated down to as low as 0.5” WC. Combination gas valves will be looked at in greater detail in [B1 LT4](#).

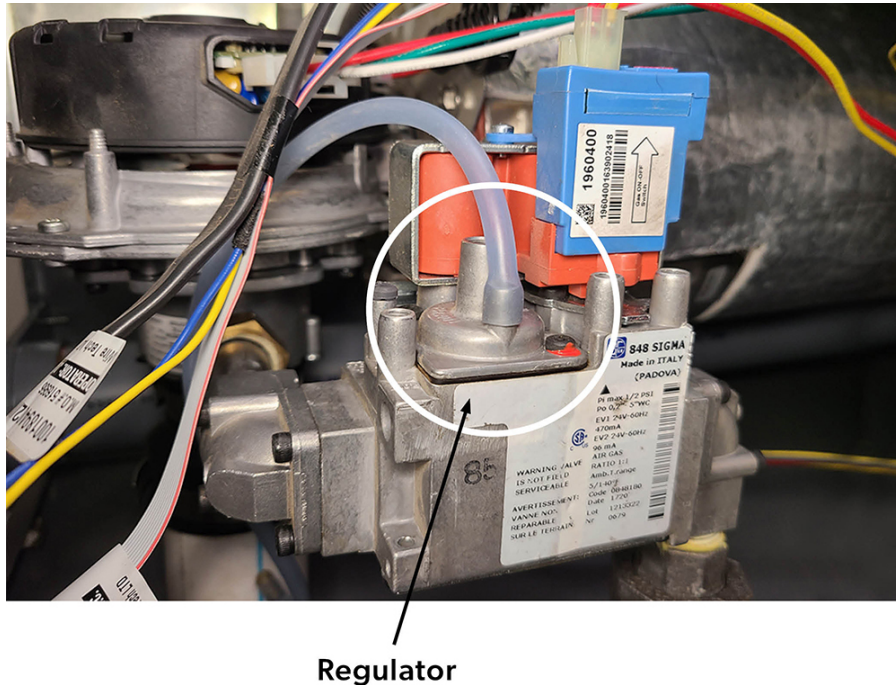

Figure 17. Appliance regulator as part of a combination gas valve

## Line pressure regulators

The service regulator will often deliver a building line pressure that exceeds the maximum allowable pressure specified for the gas appliance. In these cases, line pressure regulators are installed between the building’s service regulator, or LP-gas 2 psig (13.8 kPa) service regulator, and the gas appliance. For example, a 2 psig service will need to be reduce to a maximum of 0.5 psig (14” WC) as that is the maximum inlet pressure to most appliance regulators (Figure 18).

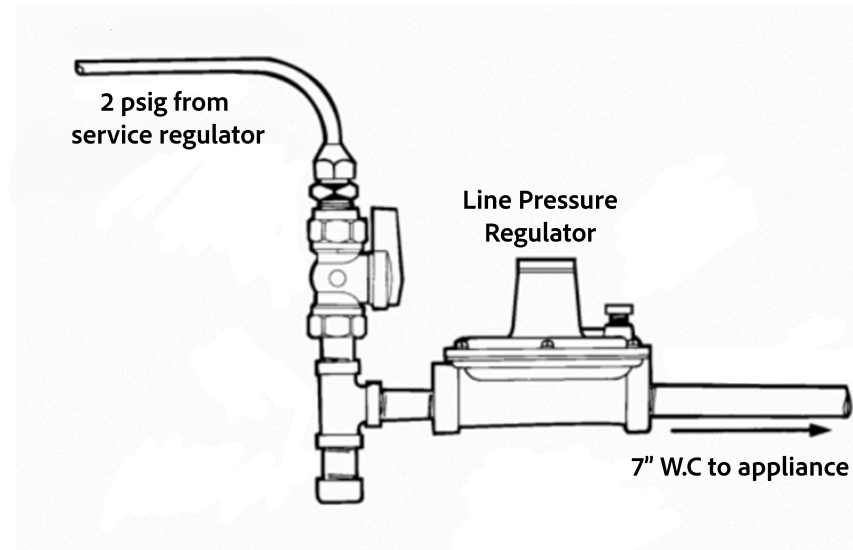

Figure 18. Line Pressure Regulator

Line pressure regulators are classified in accordance with their intended application and are designated either Class I or Class II.

- Class I regulators have a maximum outlet pressure setting of  $\frac{1}{2}$  psig as they are used primarily with residential and light commercial appliances that have  $\frac{1}{2}$  psig maximum rated inlet pressures. They can be certified for a rated inlet pressure of 2, 5, or 10 psig.
- Class II regulators have a maximum outlet pressure setting of 2 psig as they are used primarily with industrial appliances that have 2 psig maximum rated inlet pressures. They can be certified for a rated inlet pressure of 5 or 10 psig.

Line pressure regulators used for installations with a supply pressure exceeding 2 psig require a tested and approved overpressure protection device (OPD), to prevent the outlet pressure from exceeding the rated pressure of the system components.

### High pressure regulators

A high pressure regulator is similar to a line pressure regulator except it is used for applications where the inlet gas pressure is greater than 10 psig (70 kPA) and an outlet pressure is greater than 2 psig (14 kPA). An example could be if the gas service was routed directly into the mechanical room of a hotel at the maximum allowable pressure of 20 psig to serve the boiler loads, and then continued from the mechanical room into the hotel to serve other loads. This would require an additional regulator to reduce the gas pressure to a maximum of 5 psig before it left the mechanical room. The other equipment throughout the hotel would still require one or more line pressure regulators to reduce the pressure to  $\frac{1}{2}$  psig for the appliances.

## Operating types

All regulators maintain a pre-determined outlet pressure to control the quantity of gas flow. They are pressure operated, and no other power source is required for their operation. All regulators are one of these two operating types:

- Direct-operated
- Pilot operated

### Direct-operated regulators

Direct-operated regulators, also known as self-operated regulators, are the simplest type of pressure regulator and are the most common. Direct-operated regulators are a self-contained valve and actuator combination (Figure 19). They use the actual downstream pressure directly in the actuator to position the valve accordingly and match the gas demand.

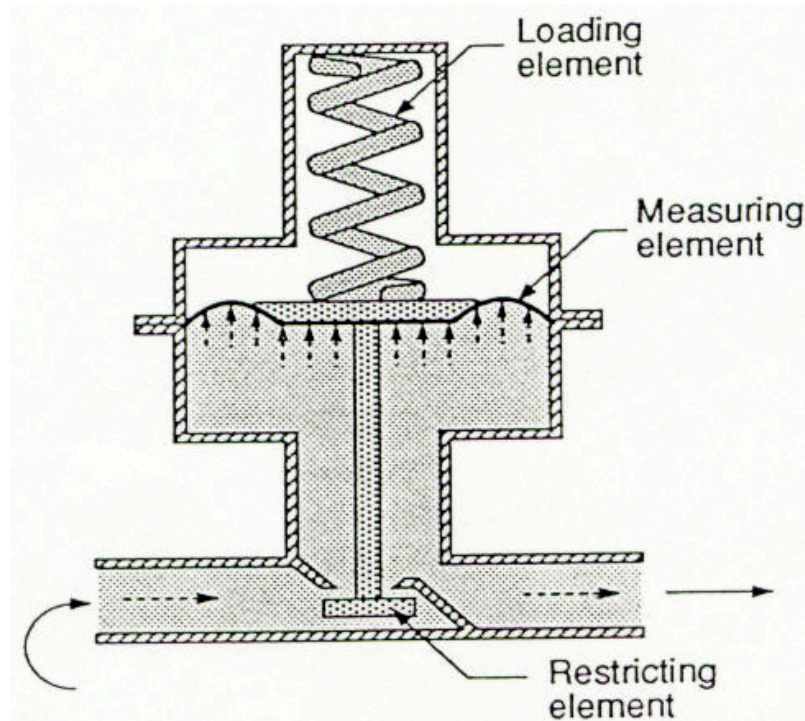

Figure 19. Direct operated regulator

In operation, a direct-operated, pressure regulator senses the downstream pressure through either internal port or an external control line. This downstream pressure opposes a spring which moves the diaphragm and valve plug to change the size of the flow path through the regulator.

### Pilot-operated regulators

Pilot-operated regulators are used for high flow rates or where precise pressure control is required. A pilot-operated regulator can be simplified by viewing it as two independent regulators connected

together (Figure 20). The smaller of the two is generally the pilot. The pilot is a pressure amplifier as it senses to downstream pressure to then create the necessary loading pressure to the main regulator diaphragm. This improves the overall sensitivity and accuracy of the regulator.

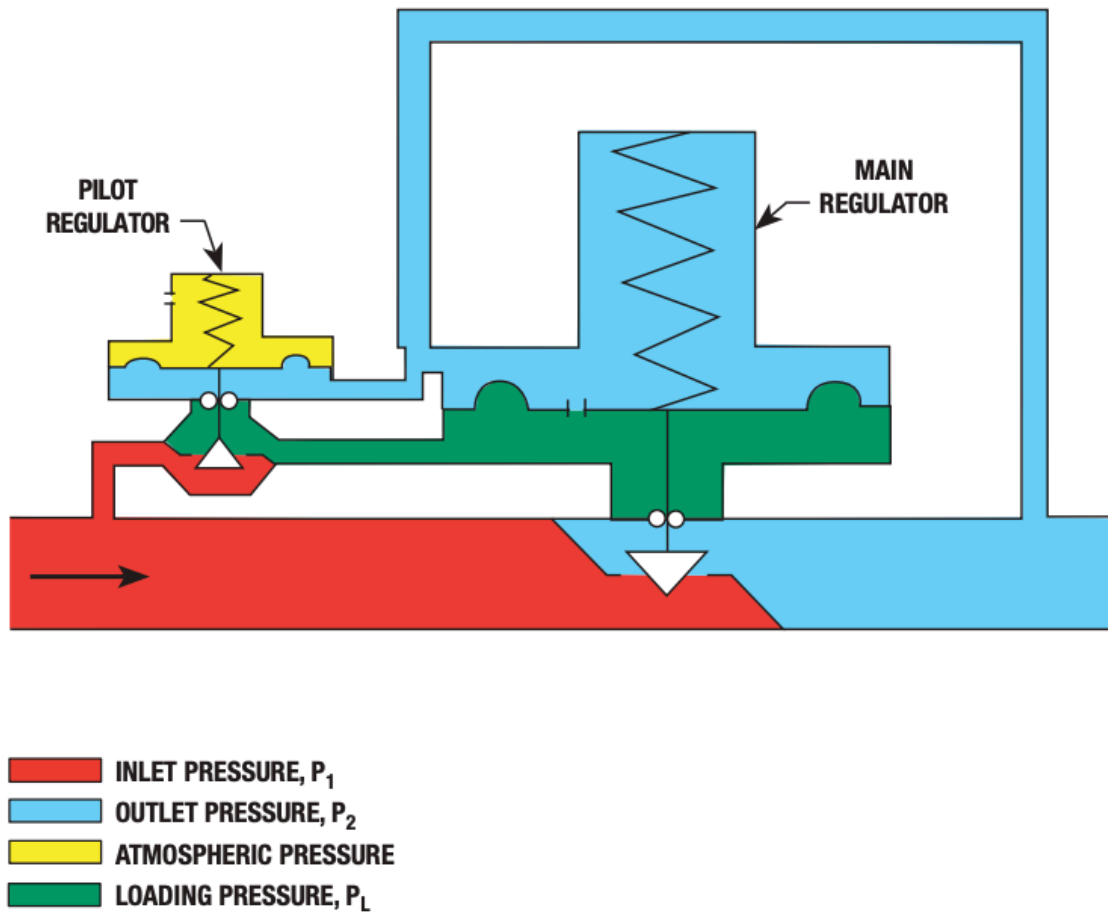

Figure 20. Pilot-operated regulator

As these regulators are primarily used on larger commercial, institutional and industrial applications they are covered in greater detail in the Class “A” training.

## Regulator Operation

Although direct -operated regulators are available in many different styles and designs their basic operating principles and the same. All regulators have three basic operating elements or components that are used to control flow rates as well as pressure shown in Figure 21.

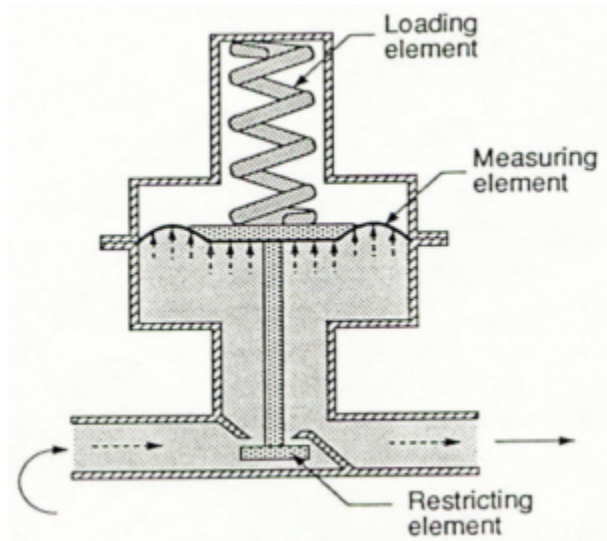

Figure 21. Operating elements

### Restricting element

The restricting element consists of the valve body, orifice, valve plug, and stem (Figure 22). Together they control the amount of flow through the orifice opening. As the stem is moved upward, the valve plug moves toward the orifice, restricting flow. Flow through the orifice is increased by moving the stem downward, away from the orifice.

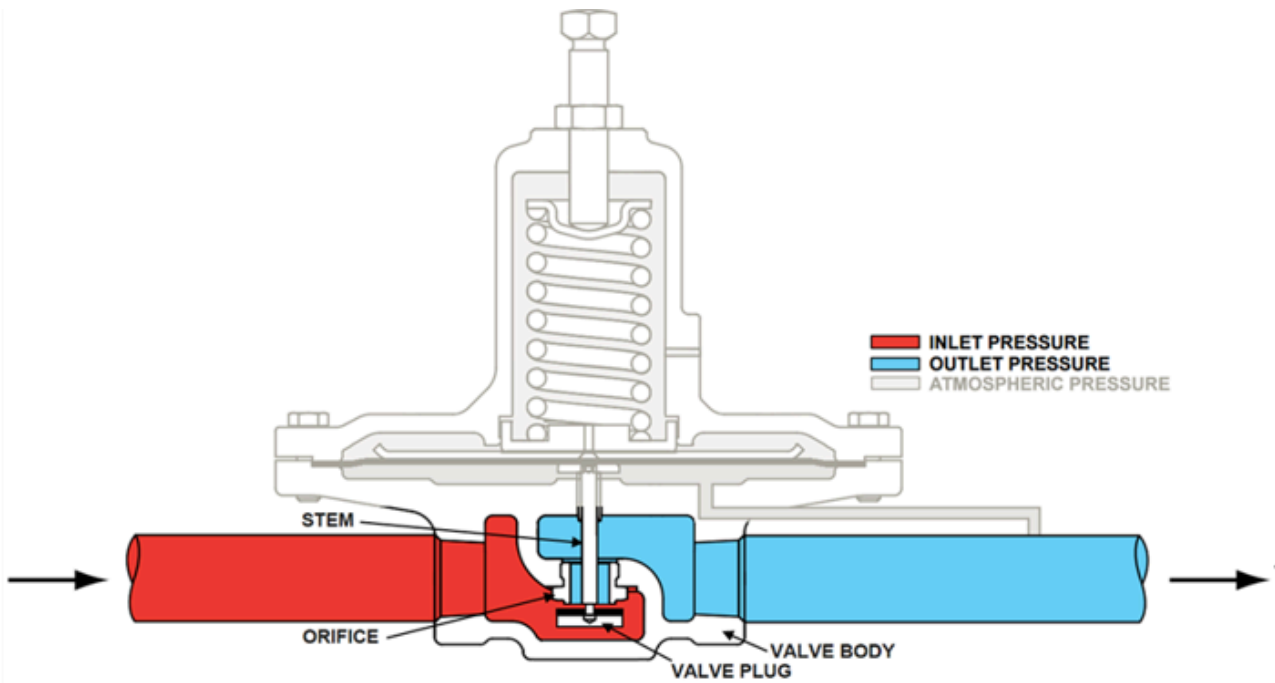

Figure 22. Restricting element

## Measuring element

The measuring element provides feedback to the regulator on whether the flow demand is being matched. The measuring element is usually a diaphragm that senses the changes in the downstream pressure (Figure 23). Made of neoprene, it is extremely flexible and usually is supported by a metal plate that allows downstream pressure to act upon the diaphragm evenly. The plate is connected to the valve stem so it will modulate the valve plug position based on the downstream pressure it senses through the control line or internal port.

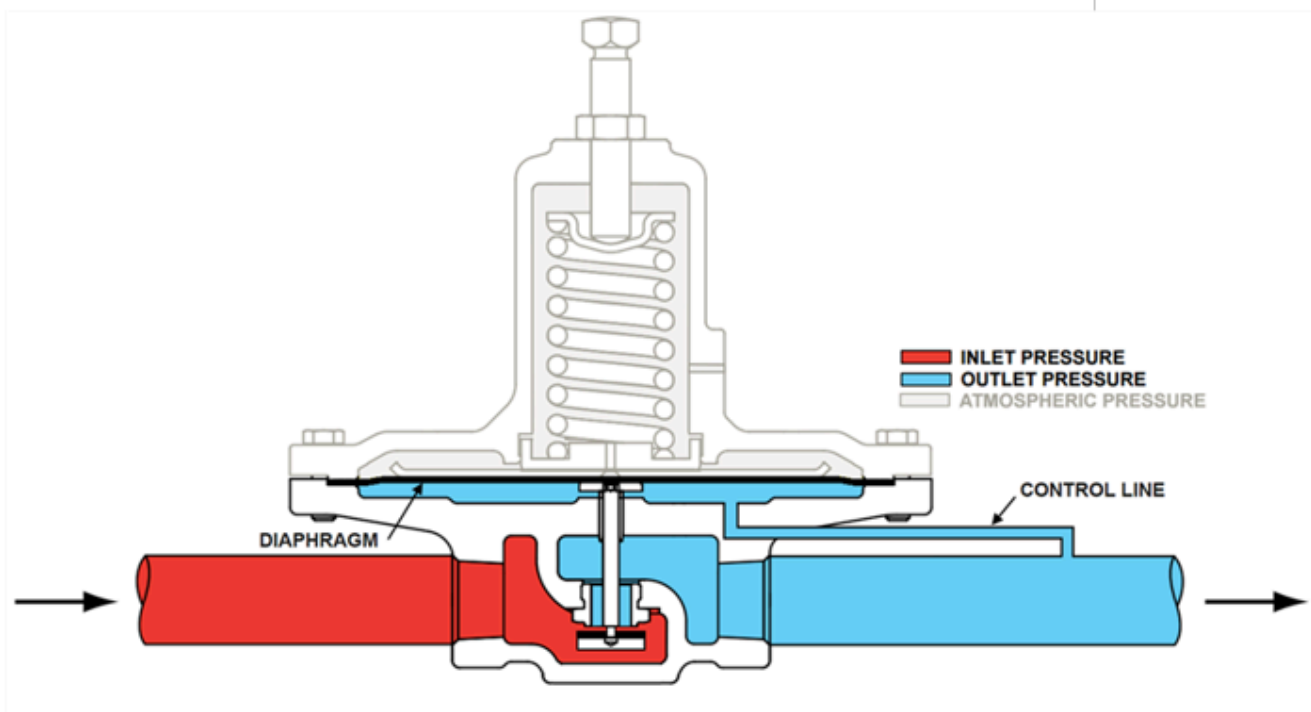

Figure 23. Measuring element

## Loading element

On modern regulator the loading element is a spring used to counter balance the force created by the downstream pressure on the underside of the diaphragm (Figure 24). The springs opening force is changed with the adjusting screw. This will adjust the desired outlet pressure, known as the regulators setpoint.

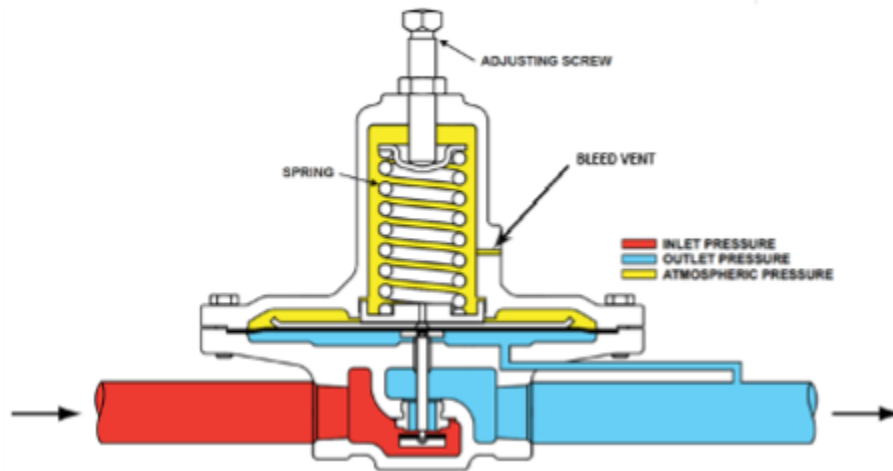

Figure 24. Loading element

## Principles of operation

To help understand the operation and troubleshooting of regulators it is worth noting that an uninstalled direct operated regulator is in the normally open (NO) position, as the closing force requires downstream gas pressure.

We will begin the operating sequence as if it is a newly installed gas piping system that is just being pressurized.

- As the system fills gas will flow through the open valve, the gas pressure downstream of the regulator will begin to increase, filling the chamber below the diaphragm causing it to move upward against the spring tension. Air exiting the upper chamber through the bleed vent allows the diaphragm to move freely. The upward movement of the diaphragm closes the valve. The amount of downstream pressure necessary to close the valve is directly related to the force exerted by the spring on top of the diaphragm. This is called the set point.
- When an appliance starts, gas pressure under the diaphragm decreases allowing the spring to push the diaphragm downward opening the valve. Air entering the bleed vent allows the diaphragm to move freely.
- The diaphragm and valve stabilize when the force under the diaphragm equals the force exerted by the spring. At this point the regulator has found its point of equilibrium and the flow rate and pressure downstream match that which is required by the system.
- If additional appliances start or an increase in firing rate occurs, the diaphragm moves further downward and the valve stabilizes in a new position in relation to the orifice, allowing more gas flow at the same pressure setpoint.
- If gas demand decreases or stops, the diaphragm moves upward and the valve stabilizes in a new position in relation to the orifice, allowing less gas flow at the same pressure. Air entering and exiting the vent allows the diaphragm to move freely.

### Adjusting setpoint

Regulators can be adjusted to change the outlet pressure setpoint within certain limits of the spring range. The desired outlet pressure can be changed by adjusting the screw in its housing (Figure 25) to increase or decrease the force exerted by the spring on the flexible diaphragm.



Figure 25. Turning adjusting screw

Use the following procedure to change the setpoint:

1. Turn off the gas.
2. Install the pressure test equipment to sense downstream pressure. Some regulators will have threaded pressure plugs on the valve body to connect (Figure 26). But many will not have gauge connections and you will need to find an appropriate connection point.

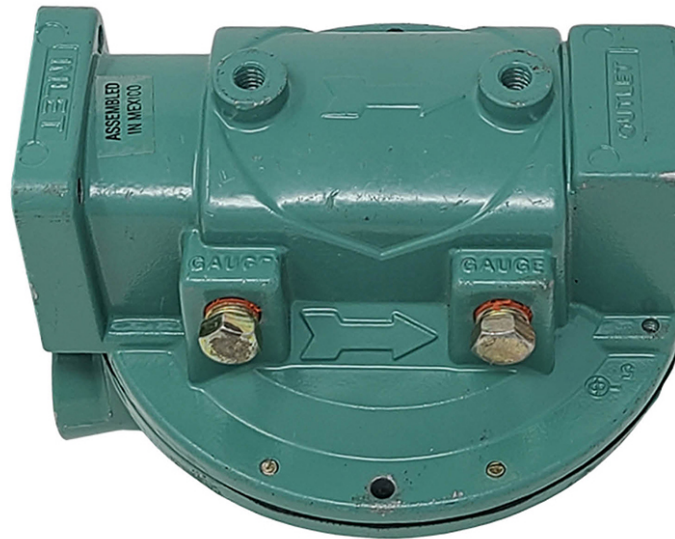

Figure 26. Regulators with pressure test ports

3. Remove the regulator adjusting screw cap.
4. Turn on the gas.
5. Turn the equipment on, allowing the gas to flow.
6. Look at the pressure and make the appropriate adjustment. To increase the outlet pressure, turn the adjusting screw clockwise to increase the tension is applied to the spring. For a lower outlet pressure, the adjusting screw is turned counter-clockwise to lessen the tension on the spring.
7. Replace the cap.
8. Shut off the gas.
9. Remove the test equipment.
10. Properly plug any test points.
11. Turn on the gas
12. Leak test the test points.
13. Check the operation of the appliances or burners downstream of the regulator to ensure that they are in safe operating condition.

## Performance Characteristics

The importance of a regulators performance characteristic is frequently misunderstood. Ideally a regulator would provide a range of flow rates with-out a drop in downstream pressure, this however is unrealistic. The only way the internal parts of a regulator will move in any direction is if the diaphragm senses a change in that outlet pressure. In order for the flow rate to increase through a regulator, the restricting element must open wider, which can only be done by a drop in pressure. If the regulator

hasn't opened enough to satisfy demand, the downstream pressure will have to decrease further for the regulator to open more. The term used for this characteristic is droop or offset.

## Droop

When the flowrate versus outlet pressure of a particular regulator is plotted the actual performance curve looks like the Figure 27. For this regulator the ideal setpoint is made at a flow of 50 SCFH, but that is the only flowrate at which outlet pressure will precisely equal setpoint. Any time the flow demand is greater than 50 SCFH, outlet pressure will droop below 1 psig.

Notice at the maximum flowrate of 500 SCFH through the regulator the outlet setpoint would be 0 psig, this would obviously not be an acceptable amount of pressure to operate any of the gas equipment.

A regulator can pass only so much flow for a given valve seat orifice size and inlet pressure. Notice how quickly the regulators performance drops off after the regulator valve has reached the wide-open position (when the disk clears the orifice by a distance equal to  $\frac{1}{4}$  of the orifice diameter). At the point of critical flow the gas has reach its maximum velocity through the orifice. This velocity is known as the sonic velocity which is the speed of sound for that particular gas. At this point the only way to increase the flow through the valve would be to increase the upstream pressure.

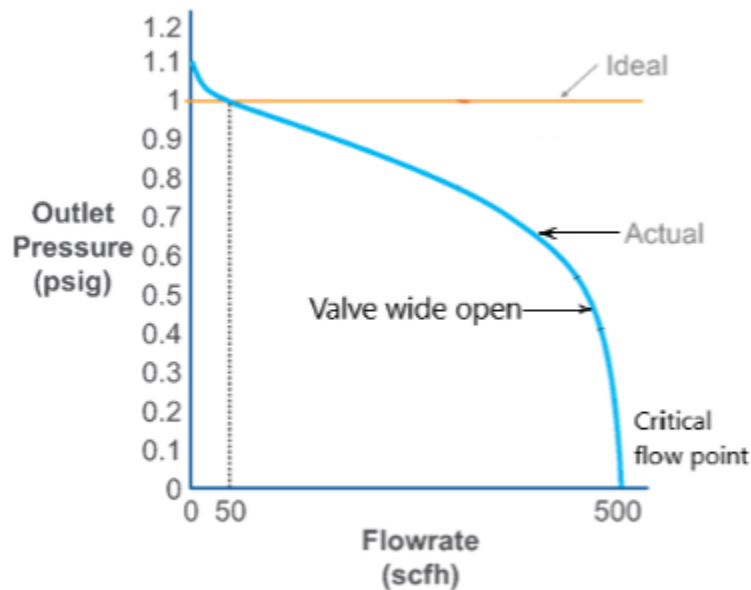

Figure 27. Regulator performance curve

In order to ensure the outlet pressure is much closer to setpoint manufactures will publish the droop as a percentage of the setpoint pressure. For propane and natural gas, droop accuracy ratings of 10% to 20% are typical.

In Figure 28 for a 20% accuracy, 275 SCFH flow would be published because that is the maximum flowrate before the regulator's performance droops outside the 20% accuracy bounds. If the flow demand is less than 275 SCFH, the outlet pressure will be closer to setpoint. Likewise, if flow demand

exceeds the published 275 SCFH, it would be less accurate and possible not deliver adequate pressure to operate the equipment and burner properly.

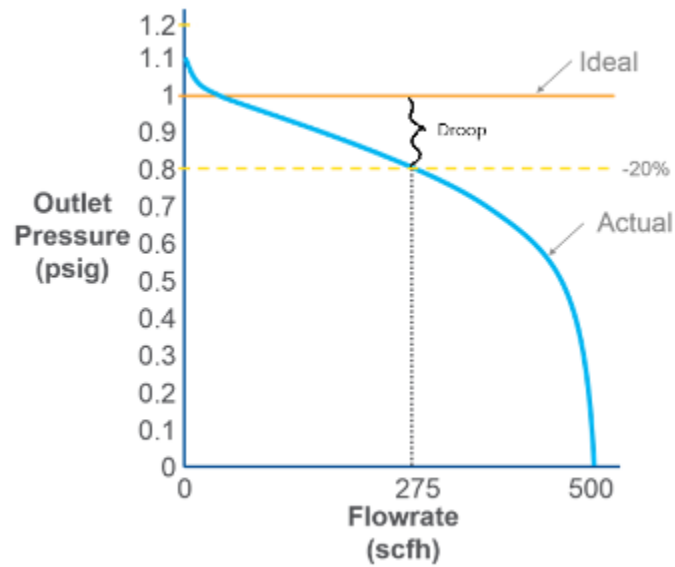

Figure 28. Droop accuracy bounds

## Lockup

The amount of increased pressure above setpoint needed to achieve shutoff is called lock-up (Figure 29). Lock-up is an important regulator characteristic because it affects how well the pressure regulator fulfills its reason for existence: maintaining a constant outlet pressure. Typically, regulators that have inlet pressures above 0.5 psig must be of the positive shut-off type, which means the valve disk has a soft seated disc and the valve seat or orifice has a tapered machined edge. These regulators will usually lock up to within 10% of the original outlet pressure setting.

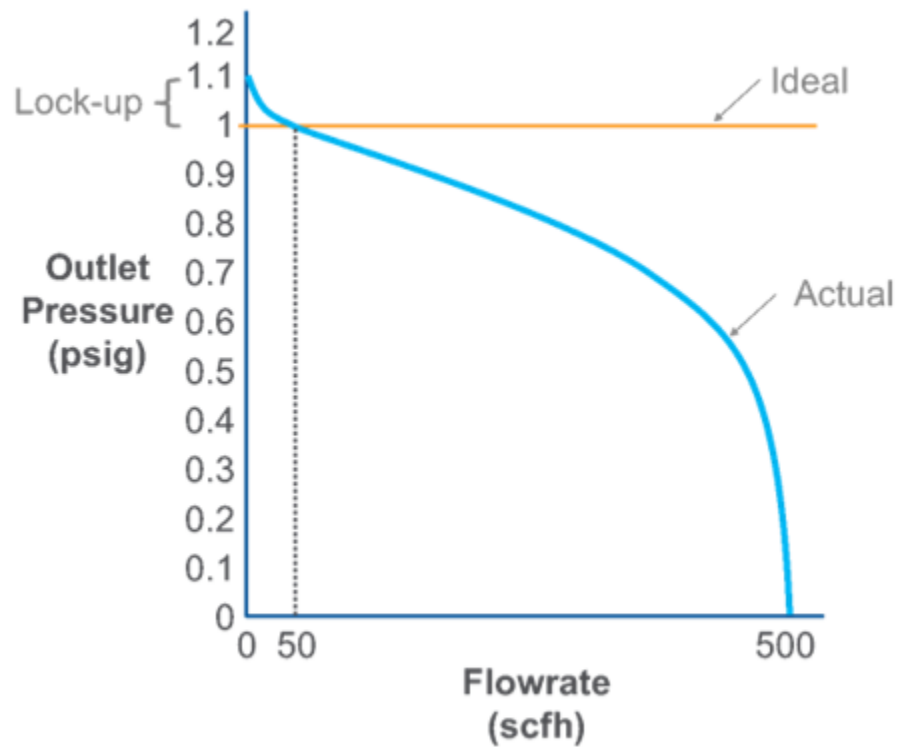

Figure 29. Lockup performance

#### Lever and cam stem operators

Service, high and line pressure regulators typically have to operate with a greater the difference in pressure between the inlet and outlet of a regulator. These conditions will require a larger diaphragm to maintain accuracy and lockup. The similar result is obtained by using a lever or a cam stem to multiply the force produced by the diaphragm. Lever and cam stem controlled (Figure 30) regulators provide increased force necessary for lockup against higher inlet pressures. The extra mechanical force also keeps the disk in a stable position, thereby opposing tendencies of the disk to cycle or buffet.

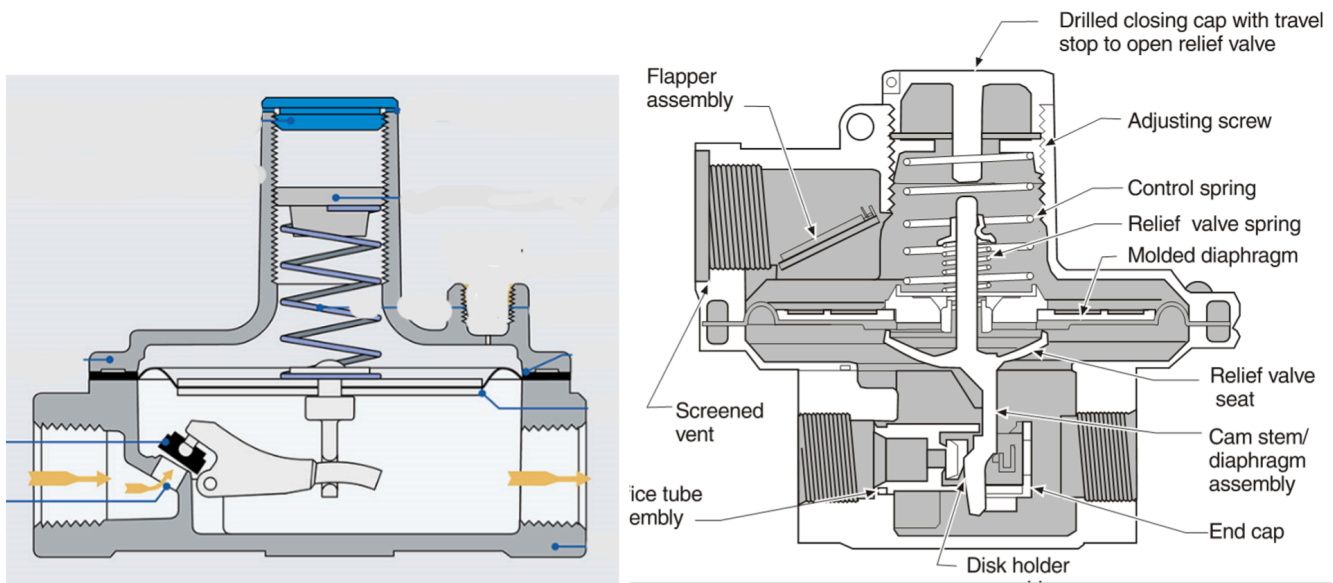

Figure 30. Lever and cam step regulators

## Boost

In the previous operating explanations regulator were used with an external control lines sensing a point downstream of the regulator. The performance curves showed that as flow increased, the regulator failed to maintain setpoint due to droop and the performance eventually fell below an acceptable pressure. The more typical regulator has an internal sensing port or tube. Internally sensing direct-operated regulators not only experience droop; they also have a counteracting force called boost that can cause the performance to exceed accuracy requirements on the high end. Boost can be used to counteract the effects of droop by extending the flowrate at which the regulator maintains accurate pressure control.

The internal sensing regulator senses the pressure inside the valve body which is a turbulent location with high velocity. At a point near the orifice outlet, called the vena contracta, the velocity is highest the pressure will be lowest. As flow demand increases, so does velocity at the sensed point, causing an increasing discrepancy between the pressure at the regulator's sense location (at the vena contracta) and the downstream pressure (Figure 31).

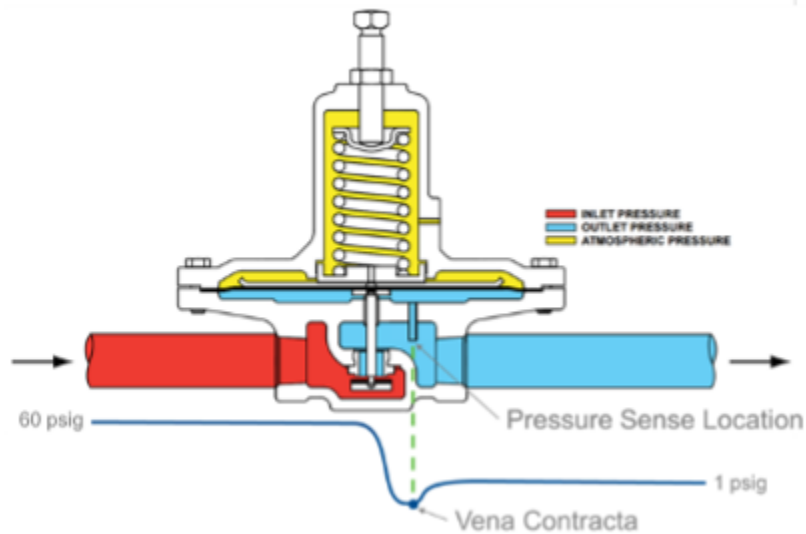

Figure 31. Vena contracta

Consequently, the internally-sensing regulator is tricked into opening farther due to this false low pressure, then if it had been sensing pressure through an external downstream control line. This increased flow can translate into improved accuracy. Some internal sensing regulators have a pitot tube in order to place the sensing point at the optimal location (Figure 32), so that the boosting effect will counteract the droop effect but not boost too much.

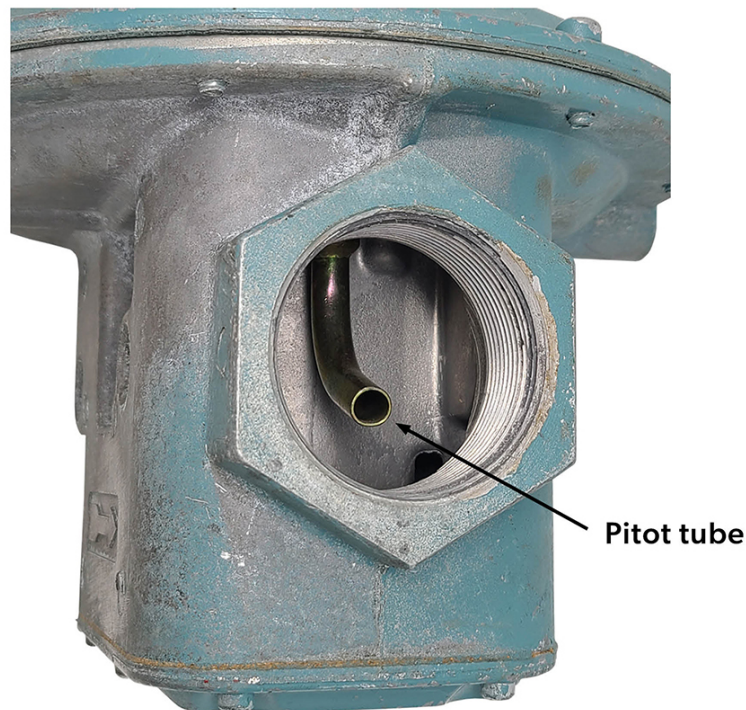

Figure 32. Pitot tube

Boost can be beneficial for extending how much of the regulator's performance curve falls within the

published accuracy. Figure 33 is an example of an internally registered unit that boosts so much that it almost exceeds the upper accuracy bound. For 20% accuracy, the maximum flowrate published would be 450 SCFH which is much better than the 275 SCFH that would be published for the same regulator previously discussed with an external control line.

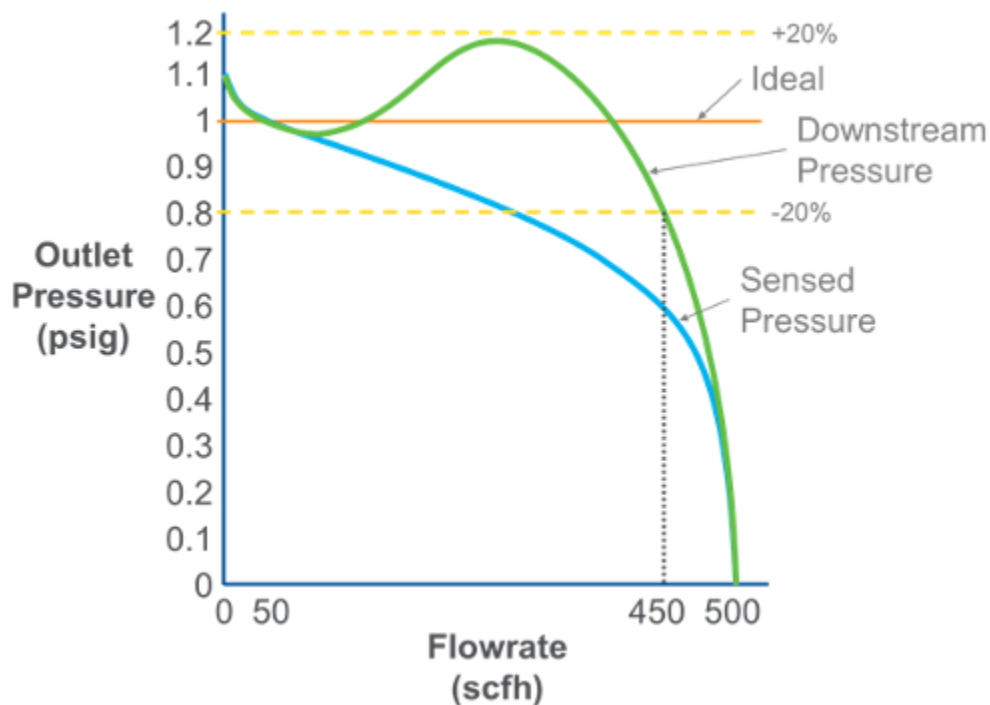

Figure 33. Regulator boost performance curve

### Balanced diaphragm

Another method that regulator manufacturers use to overcome the effects of the inlet pressure on the valve seat is to add a balancing diaphragm (Figure 34). The inlet pressure exerted downwards on the inner valve disk also pushes upwards on the balancing diaphragm. The effective areas are equal, so the forces push equally in both directions. The balancing diaphragm is attached and sealed to the valve shaft and separates the lower main diaphragm area and the upper valve section. This design makes it possible to maintain steady outlet pressure control with widely varying inlet pressures, and minimum lockup with either high or low inlet pressures.

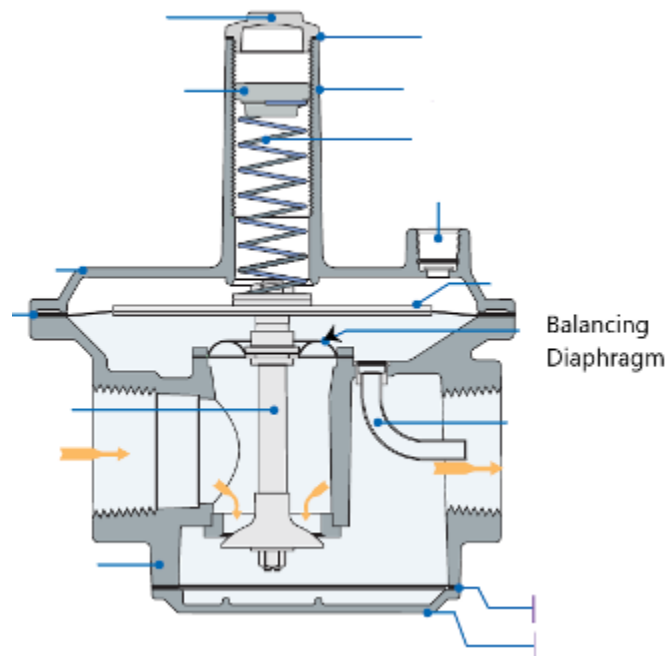

Figure 34. Balanced diaphragm regulator

## Regulator Vent

The regulator vent (atmospheric vent, bleed vent) is an essential part of the regulator, so much that it is sometimes referred to as the fourth operating element of the regulator. It allows the air above the diaphragm to escape or enter as the diaphragm moves up or down. If the vent is blocked or restricted, the diaphragm is not able to move properly. For example, if the vent was completely blocked it would cause the air above the diaphragm to become locked in and prevent the diaphragm from raising enough to close the restricting element. This will create a situation in which the downstream pressure will rise above the required setpoint.

If the vent were partially blocked or restricted, the air movement would be delayed as the diaphragm attempts to force air out and pull air through the vent opening. This would in turn cause wide swings in downstream pressure above and below the setpoint known as “hunting” or “cycling”.

The vent also allows gas to escape if the diaphragm ruptures or an internal relief valve opens. There are special installation safety measures that are required to control this potential escaping gas that will be discussed in Section B-2.

## Propane Systems

Propane systems are different than natural gas systems in that the propane supply pressure from the storage tank will vary due to changing air temperature. Propane storage container pressures could vary from as low as 8 psig (55 kPa) in winter to as high as 220 psig (1 500 kPa) in summer. For any regulator the greater the difference in pressure between the inlet and outlet of a regulator, the more difficult it is for the regulator to maintain accuracy. This is why propane systems typically use two

regulators between the propane tank and the appliance. For example, the CSA B149.1 code states; that two stage reduction is required for all permanent installations and that the pressure between the first stage and second stage regulator shall not exceed 10 psig. However, this maximum allowed pressure difference should be reduced to 5 psi in colder climates, to prevent the vapor from changing into liquid.

By doing a two stage reduction the first stage of the system supplies a nearly constant inlet pressure of 8 to 10 psig (55 to 70 kPa) to a second-stage regulator. This means that the second-stage regulator does not have to compensate for as much variance in inlet pressures, as the first stage regulator will supply it with a relatively constant inlet pressure.

There are two methods that are used for two stage regulation which were shown previously in Figure 13.

- Two separate regulators – one on the tank and one at the building entrance, or
- One twin stage regulator that performs both functions internally. Used only when piping distances are 30 ft (9 m) or less from the tank to the building.

## Mechanical burners

Mechanical burners use a fan, blower, or compressed air to supply the required amount of combustion air and may also assist in venting the products of combustion.

In the past mechanical burners were primarily found only in industrial and large commercial combustion systems. With the modulating condensing technology used on most modern-day small commercial and residential appliances, mechanical burners are very common. These often come in the form of a pre-mix burner that will mix the gas and air upstream of the burner port.

Nozzle mix burners mix the gas and air together as they enter the burner nozzle. Both the air and gas are injected into the burner at a positive pressure (Figure 35). On a variable input appliance (modulating) the air pressure or flow can be modulated but the gas pressure or flow must also be automatically adjusted to remain in direct proportion to the air.

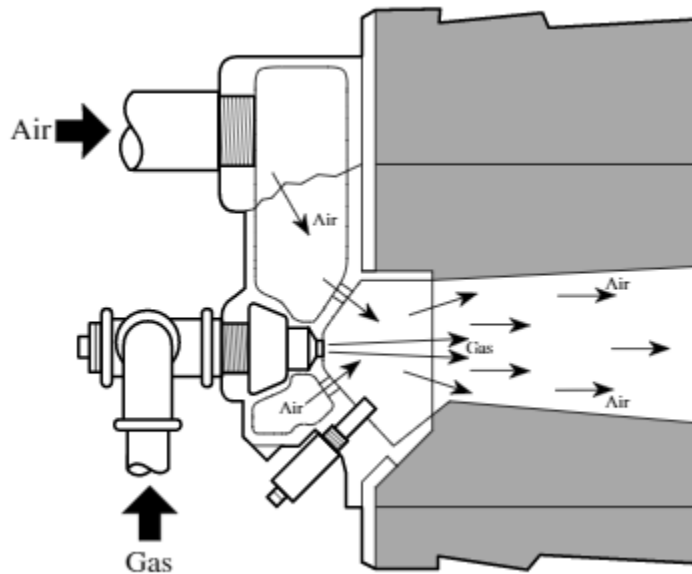

Figure 35. Nozzle mix burner

The aspirator (venturi) type of pre-mix burner (Figure 36) uses high velocity air travelling through a venturi to entrain and mix with the required gas supply.

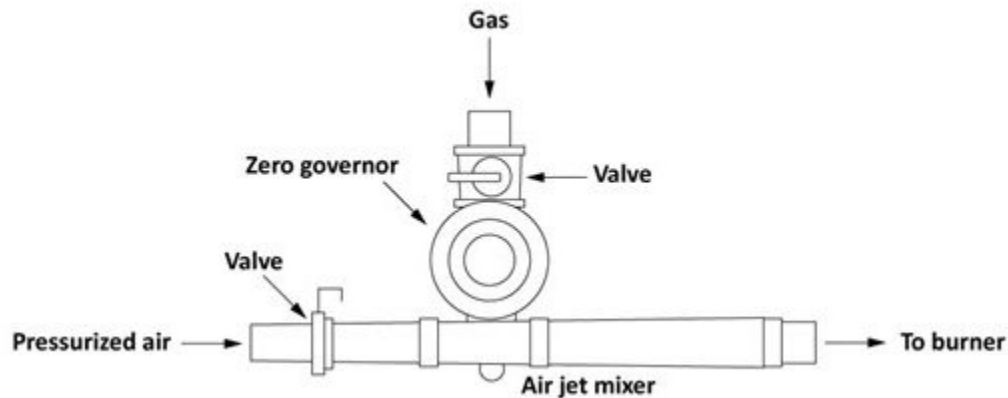

Figure 36. Aspirator (venturi) mixer

To maintain proportion gas/air mixtures, venturi modulating burner systems require a pressure regulator that can automatically change its gas flowrate to match a change in the combustion air supply. These regulators are called zero governor/ratio regulators.

### Zero governor/ratio regulators

Zero governor regulators control the outlet pressure with a goal of zero pressure, relative to atmosphere, at the outlet. They will allow the flow of gas only occur when a negative pressure is sensed at the valve outlet. They sense the reduced pressure at the venturi when the combustion air is flowing, and open in proportion to the speed of the air flow.

They are balanced diaphragm designs with a very light balancing spring designed to only lift the force created by the weight of the moving parts (Figure 37A).

For another very common design shown in Figure 37B, the manufacturers have simply added a counterbalancing spring to the under side of the valve disc of their balanced diagram regulator. The counterspring acts against the downward forces created by the setpoint spring and the weight of the moving parts. It should be noted these rely on gravity so should no be mounted upside down.

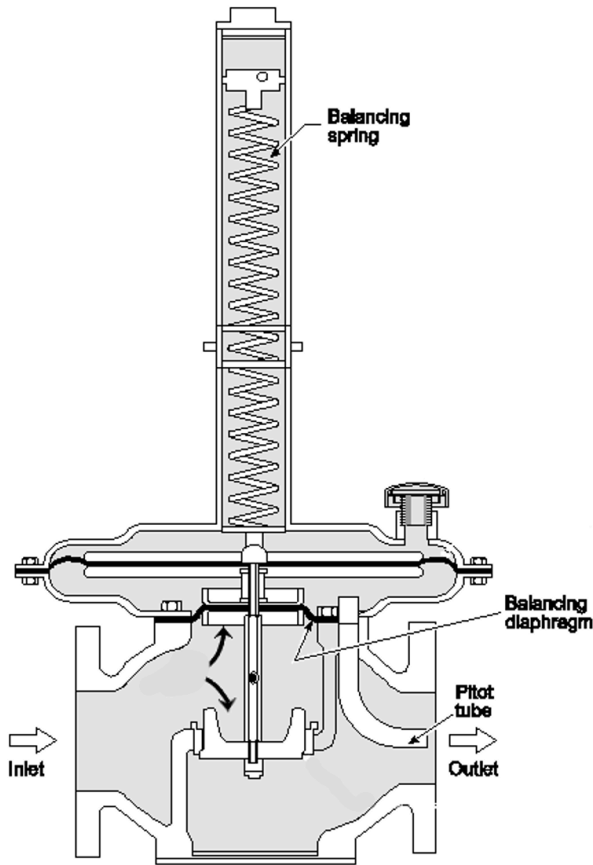

**Figure 37A**

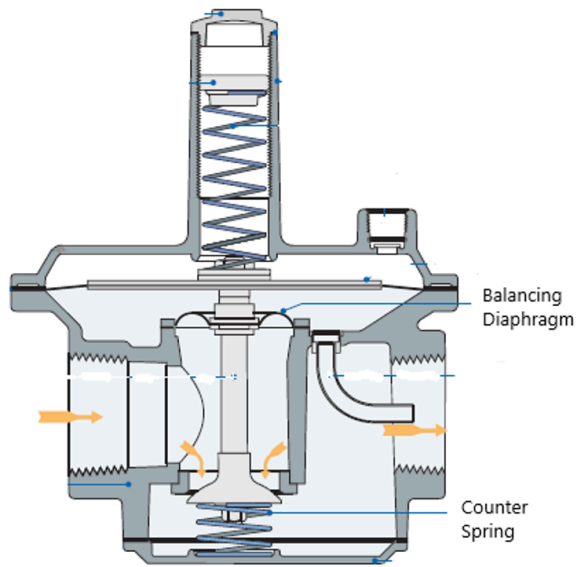

**Figure 37B**

*Figure 37. Zero governor regulators*

These regulators are ideal for gas engines and modulating aspirator burners as they will automatically change the gas flow to match any changes in the air flow through the venturi mixer (Figure 38).

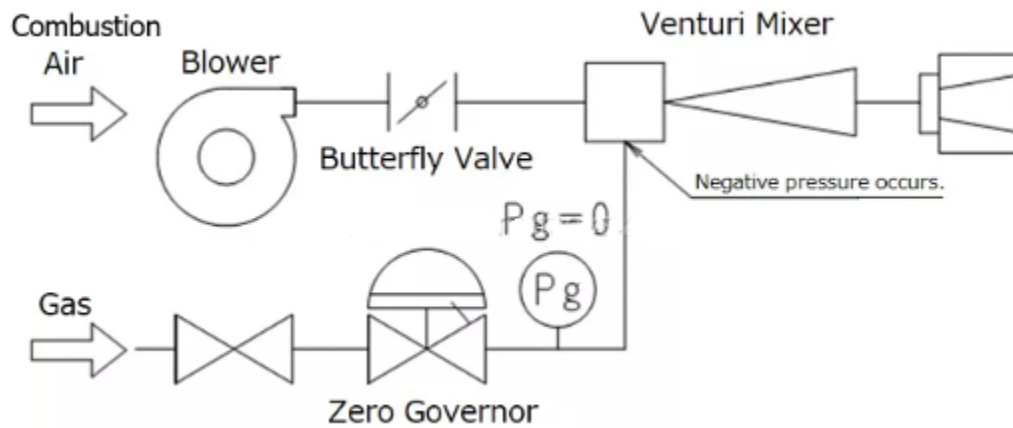

Figure 38. Venturi mixer schematic

Commercial and residential modulating/condensing boilers and on-demand water heaters, will have all of the components in one packaged burner assembly (Figure 39). A zero governor servo regulator is incorporated into the combination gas valve. Instead of a butterfly valve to adjust the combustion air flow a variable speed motor is used on the blower to change the air flow. As the blower modulates to meet the heat demand the zero governor changes the gas input to automatically achieve proportional mixing.

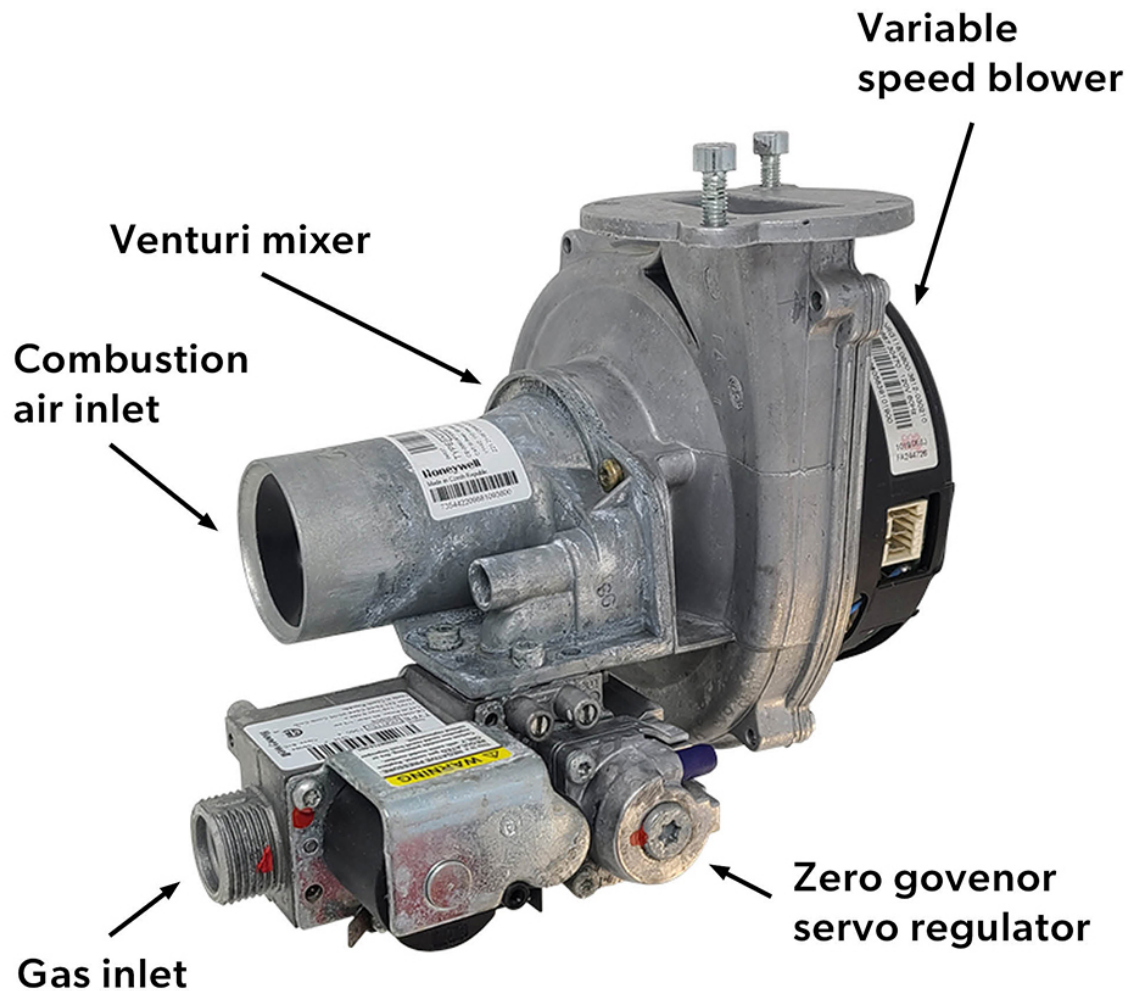

Figure 39. Venturi Mixing Burner Assembly

For nozzle mix burners a ratio (equalizing) regulator supplies gas to a burner at a pressure that is in direct (1:1) proportion to the air pressure supplied to the burner (Figure 40). As the air pressure to the burner increases, then the ratio regulator causes the gas pressure at the gas limiting orifice to increase. Conversely, if the air pressure decreases, then the gas pressure decreases. A ratio regulator is a zero governor regulator with a sensing tube connected to the regulator bleed vent. This line loads the air pressure into the diaphragm chamber, causing the loading element force to increase. The result is a gas pressure setpoint that will match the combustion air pressure. When there is no air pressure this zero governor type regulator will return to the closed position.

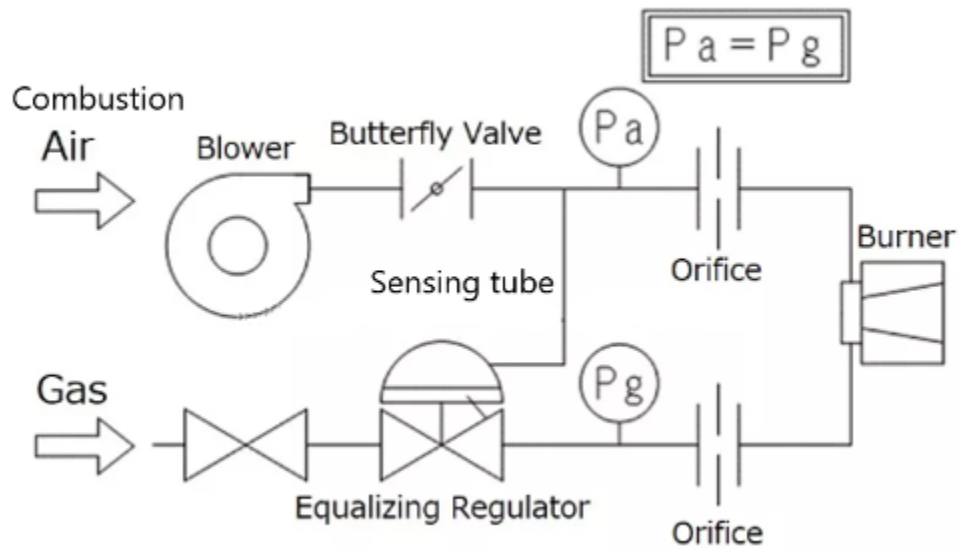

Figure 40. Nozzle mixer schematic



Now complete Self-Test 3 and check your answers.

### Self-Test 3

#### Self-Test 3



An interactive H5P element has been excluded from this version of the text. You can view it online here: <https://opentextbc.ca/plumbing4b/?p=34#h5p-3>

### Media Attributions

- Figure 14. “Natural gas meter set” by Rod Lidstone is licensed under a [CC BY-NC-SA licence](#).
- Figure 15. “Propane service regulators” – The source for this image is unknown. It is being

used for non-commercial, educational purposes. To receive credit for this image, please reach out to the publisher.

- Figure 16. “Appliance regulator in valve train” by Rod Lidstone is licensed under a [CC BY-NC-SA licence](#).
- Figure 17. “Appliance regulator as part of a combination gas valve” by Rod Lidstone is licensed under a [CC BY-NC-SA licence](#).
- Figure 18. “[Line Pressure Regulator](#)” from Ordan Thermal Products LTD is used and adapted for educational purposes under the basis of fair dealing.
- Figure 19. “[Direct operated regulator](#)” from Diploma In Gas Engineering Technology is used for educational purposes under the basis of fair dealing.
- Figure 20. “[Pilot-operated regulator](#)” from Emerson is used for educational purposes under the basis of fair dealing.
- Figure 21. “[Operating elements](#)” from Diploma In Gas Engineering Technology is used for educational purposes under the basis of fair dealing.
- Figure 22. “[Restricting element](#)” from Emerson is used and adapted for educational purposes under the basis of fair dealing.
- Figure 23. “[Measuring element](#)” from Emerson is used and adapted for educational purposes under the basis of fair dealing.
- Figure 24. “[Loading element](#)” from Emerson is used and adapted for educational purposes under the basis of fair dealing.
- Figure 25. “Turning adjusting screw” by Rod Lidstone is licensed under a [CC BY-NC-SA licence](#).
- Figure 26. “Regulators with pressure test ports” by Rod Lidstone is licensed under a [CC BY-NC-SA licence](#).
- Figure 27. “[Regulator performance curve](#)” from Emerson is used and adapted for educational purposes under the basis of fair dealing.
- Figure 28. “[Droop accuracy bounds](#)” from Emerson is used and adapted for educational purposes under the basis of fair dealing.
- Figure 29. “[Lockup performance](#)” from Emerson is used and adapted for educational purposes under the basis of fair dealing.
- Figure 30. “Lever and cam step regulators”.
  - “[325-L series Line Pressure Regulators](#)” (Left) from Maxitrol is used and adapted for educational purposes under the basis of fair dealing.
  - “Cam step regulator” (Right) – The source for this image is unknown. It is being used for non-commercial, educational purposes. To receive credit for this image, please reach out to the publisher.
- Figure 31. “[Vena contracta](#)” from Emerson is used and adapted for educational purposes under the basis of fair dealing.

- Figure 32. “Pitot tube” by Rod Lidstone is licensed under a [CC BY-NC-SA licence](#).
- Figure 33. “[Regulator boost performance curve](#)” from Emerson is used and adapted for educational purposes under the basis of fair dealing.
- Figure 34. “[Balanced diaphragm regulator](#)” from Maxitrol is used and adapted for educational purposes under the basis of fair dealing.
- Figure 35. “Nozzle mix burner” – The source for this image is unknown. It is being used for non-commercial, educational purposes. To receive credit for this image, please reach out to the publisher.
- Figure 36. “[Aspirator \(venturi\) mixer](#)” by Camosun College is licensed under a [CC BY 4.0 licence](#).
- Figure 37. “Zero governor regulators”.
  - Figure 37A (Left) – The source for this image is unknown. It is being used for non-commercial, educational purposes. To receive credit for this image, please reach out to the publisher.
  - Figure 37B (Right). “[R Series](#)” from Maxitrol is used and adapted for educational purposes under the basis of fair dealing.
- Figure 38.”[Venturi mixer schematic](#)” from ITO Corporation is used for educational purposes under the basis of fair dealing.
- Figure 39. “Venturi Mixer Burner Assembly” by Rod Lidstone is licensed under a [CC BY-NC-SA licence](#).
- Figure 40.”[Nozzle mixer schematic](#)” from ITO Corporation is used for educational purposes under the basis of fair dealing.



---

## Learning Task 4

### Describe Automatic Gas Valves

Compared to manual gases that involve direct physical contact with a lever or hand wheel, automatic valves are controlled by electric, hydraulic, or pneumatic signals from sensors. The valves can be set to open, close, or modulate flow.

As was mentioned in the discussions on valve train components in LT2, the automatic valves control the flow of gas to the appliance burners. On a gas valve train automatic valves are used for one of two purposes either:

- A safety shut-off valve to protect against system failures
- Operating valve to control the normal on, off operation of the burners.

For appliances with inputs less than 400 MBH the appliance automatic safety shut-off valve and the operating valve are both included as part of a combination gas valve. The ways in which these two valves are actuated and sequenced is often tied to the type of flame detection system being used. It could be helpful to review the Plumber 3 Competency E-6, Select Flame Safeguards at this time.

Abbreviations and definitions used in this learning task will include:

- **VAC** – Volts Alternating Current
- **VDC** – Volts Direct Current
- **mV DC** – Millivolts Direct Current
- **NTC** – Negative Temperature Coefficient, used to describe a thermistor whose resistance *decreases* with increasing temperature.
- **PTC** – Positive Temperature Coefficient, used to describe a thermistor whose resistance *increases* with increasing temperature
- **HIS** – Hot Surface Ignition, AKA Glow Bar
- **DSI** – Direct Spark Ignition
- **ECO** – Energy Cut-Off
- **TCO** – Temperature Cut-Off
- **FVIR** – Flammable Vapour Ignition Resistant
- **FV sensor** – Flammable Vapor sensor

### Automatic safety shut-off valve

The Automatic safety shut-off valve is one of the most important valves in the valve train and it may be

an individual component or part of a combination gas control. Its function is to provide gas shut-down if a dangerous situation could result from the build up of gas with no controlled ignition source. The gas safety valve shuts off the gas supply when de-energized by a combustion safety control, safety limit control, or loss of actuating medium. Safety shut-off valves are most often electrically operated.

## Automatic operating control valve

A sensing device will typically activate the automatic gas valve, allowing the gas to flow to the burners where ignition will take place. There are many types of automatic gas valves with various sensing devices and activation methods. Two common methods of operation include:

- Electric: a control circuit is energizes or de-energizes an electromagnetic solenoid to activate the valve. The control circuit is usually operated by 24 VAC but may be 120 VAC or mV DC.
- Mechanically (non–electric): mechanical sensing device such as a capillary tube with bellows, or rod and tube, acting directly as the valve operator.

## Electric gas control valves

The majority of automatic gas control valves are electrically actuated and are primarily used to control gas flow to main or pilot burners.

### Solenoid valve

The solenoid gas valve uses the elementary concept of electromagnetic coil which we will also see in many more complex gas valves. When the control circuit is activated it energizes the magnetic coil pulling an armature (valve stem) up into the coils center lifting the valve disk off of a valve seat. This allows gas to flow to the burner. When the controller is satisfied it opens the control circuit and de-energizes the electro-magnet (coil) causing the valve disk to fall back onto the seat from its own weight and the upstream gas pressure (Figure 41).

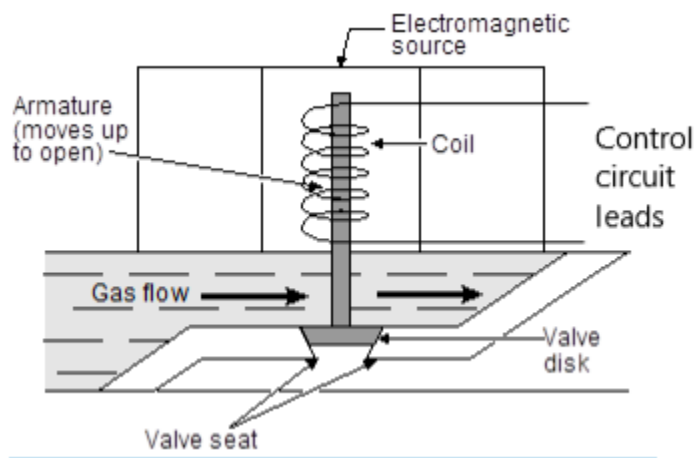

Figure 41. Solenoid valve

Some models may also have a very light spring to initiate the downward movement, but they all rely upon the weight of the disc and stem to seat them and must be installed in an upright position. This valve operates on 120 or 24 VAC circuits only (not millivoltage) and are commonly used on pilot lines of large input appliances (Figure 42).

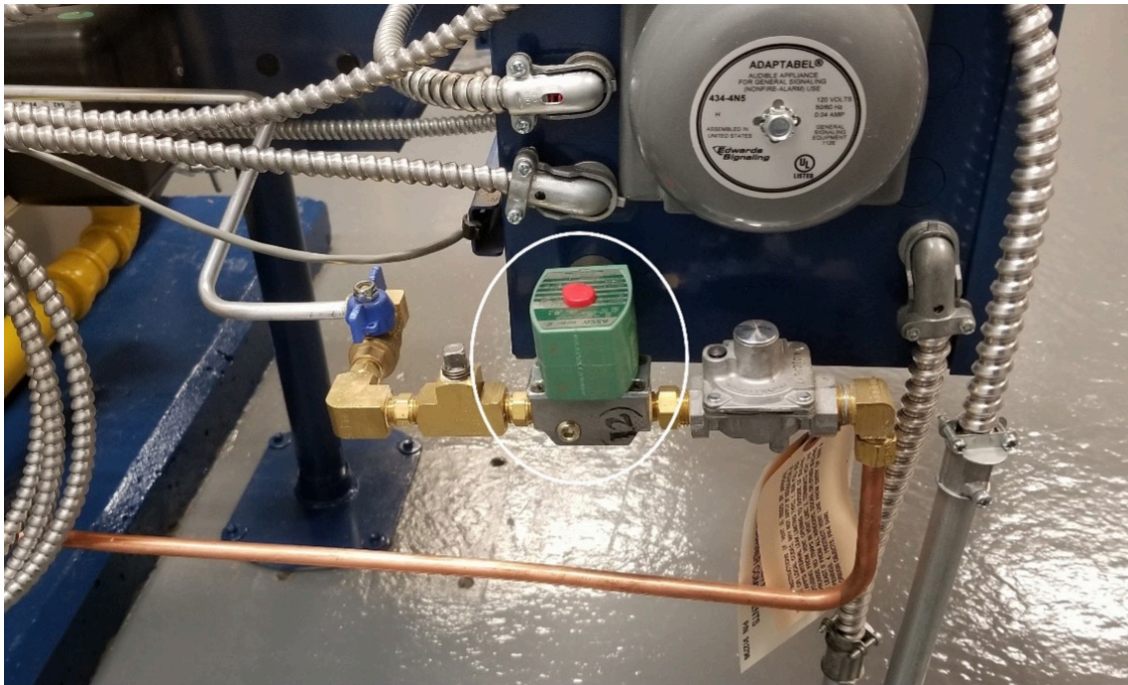

Figure 42. Pilot burner solenoid valve

### Thermoelectric valve

Thermoelectric gas valves are powered by DC current supplied by a thermocouple or thermopile. One example is the continuous pilot safety shut-off valve, powered from a thermocouple producing 30 millivolts. Thermoelectric safety shut-off valves are often referred to as *Pilotstats*, as they thermally monitor the status of the pilot flame. As long as the pilot flame exists the main burner will be safely lighted. If the pilot flame is not present then the flow of fuel must be shut off. If the flow of gas to both the main burner and the pilot burner stops, it is referred to as 100% safe. On some systems, only the main burner is isolated on pilot outage and gas flow is allowed to continue to the pilot burner. This type of system is referred to as non 100% safe, 80% safe or as a “wild pilot”. Figure 43 shows three different possible positions of the safety shut-off valve for a continuous pilot application:

- In position A, the thermocouple is deenergized and the valve is in the closed position, there is no gas flowing to either the pilot or main burners
- In position B, the reset button is being manually depressed. Gas can only flow to the pilot burner where it is manually lit. Once the pilot is lit, and the button is held, the thermocouple is heated by the pilot burner energizing the electromagnet.
- In position C, once the thermocouple is adequately heated it will produce enough voltage for the electromagnet to hold the main valve open when the button is released. In addition to the pilot, the gas is now also available to the operating automatic gas valve for the main burner.

- If the pilot were to be extinguished the thermocouple would cool, deenergizing the electromagnet, releasing the keeper, and returning the valve to position A.

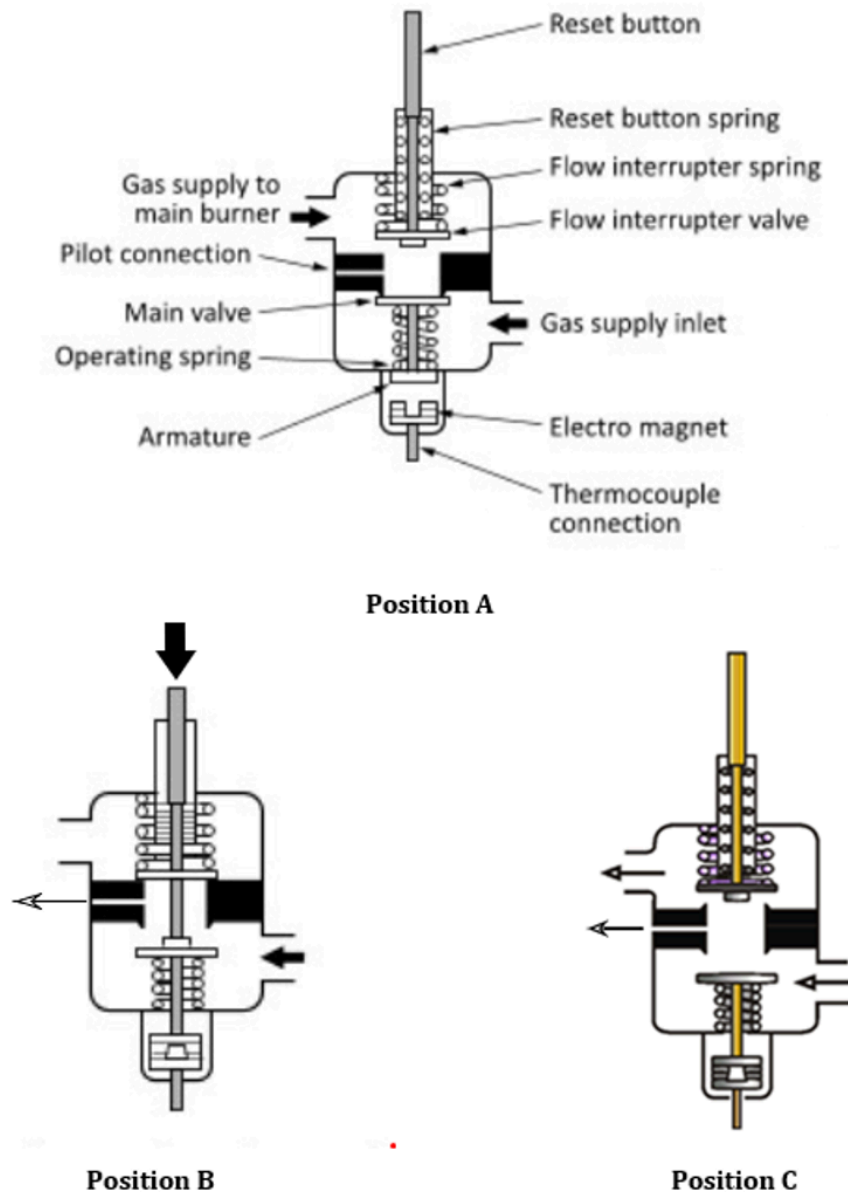

Figure 43. Automatic safety shut-off valve operation

Time of operation is an important factor with automatic safety shut-off valves. The maximum flame failure response time (F.F.R.T.), that is, the time elapsed from when the flame is lost until the gas valve is de-energized:

- 90 seconds for gases that are lighter than air when the appliance has a maximum input of 400 MBH.
- 20 seconds for gases that are heavier than air when the appliance has a maximum input of 400 MBH.

- 4 seconds for appliances with an input exceeding 400 MBH.

Figure 44 shows the pilotstat solenoid module (power unit) removed from a storage water heater combination gas valve, with a connected thermocouple. The module has been removed from the body of the valve aligned with its appropriate internal location. Notice that the pilotstat is the first internal component after the gas inlet, within the combined gas valve. Therefore the gas must flow through the safety shutoff valve before it is made available to the internal thermostatic automatic gas valve.

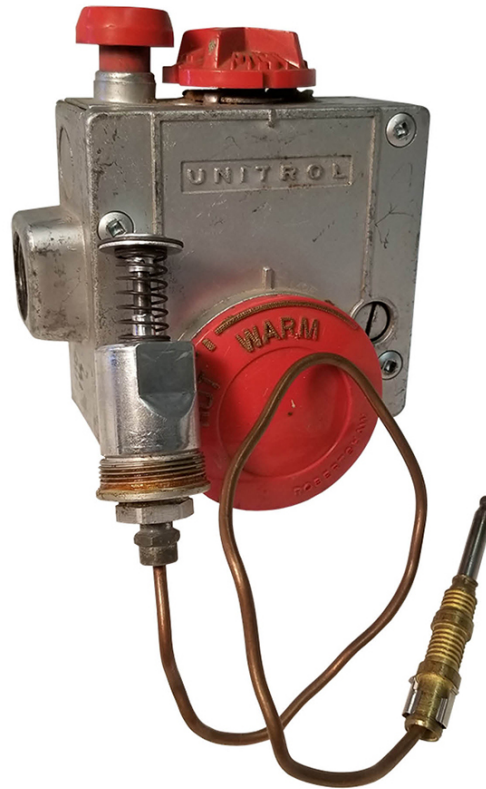

*Figure 44. Water heater combination gas valve*

## **Diaphragm valve**

The diaphragm gas valve (Figure 45) is a pilot operated solenoid-valve, in that it uses available inlet gas pressure as the primary force to open or close the valve.



*Figure 45. 1 1/2" Diaphragm gas valve*

They are simply an on/off automatic valve, and do not regulate or modulate the flow (Figure 50):

1. On a call for heat the electromagnet is energized.
2. The electromagnet then pulls the armature into a position that blocks off the pressure port, allowing gas pressure above the diaphragm to bleed off through the vent port to a standing pilot flame (Figure 46 left).
3. The pressure differential across the main diaphragm is greater than the spring force, so the diaphragm lifts the valve disc from the valve seat, allowing gas to flow through the valve to the burner.
4. When the heat call has been satisfied, the electromagnet becomes de-energized and the armature return spring pulls the armature into a position that blocks off the vent port (Figure 46 right).
5. Upstream working gas enters the pressure port and pressurizes the top of the diaphragm.
6. When the pressures above and below the diaphragm are equal, the spring will cause the valve to move down to the closed position. Once closed the under-side area being acted upon by gas pressure has been reduced causing additional force on the top to increase the sealing force on the valve seat.

*Note the diagram is not to scale as the pressure port is actually the size of a pin hole, therefore the*

armature and electro magnet can block gas flow with very little force. This enables diaphragm operated valves to be operated with lower voltage such as millivolts.

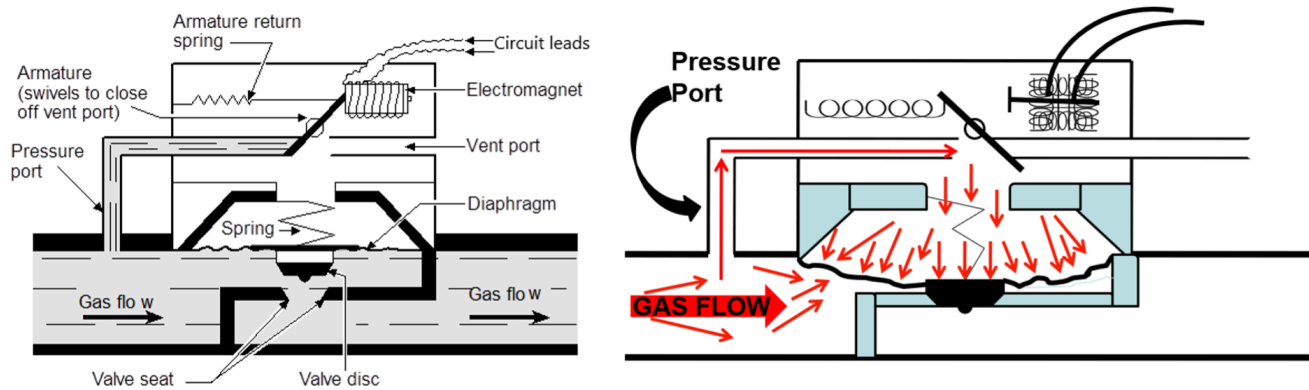

Figure 46. Diaphragm gas valve operation

Although this style of diaphragm valve is rare today it serves well as an introduction to an important concept still used on most automatic gas valves. Figure 47 represents another more common version of the diaphragm gas valve. Notice some of the differences:

- An internal bleed line vents the gas back into the outlet chamber
- The valve disc is inverted and working gas pressure is diverted to the underside of the diaphragm
- The armature return spring is compressed when the operator is energized.
- The restricting orifice controls the valves opening rate.

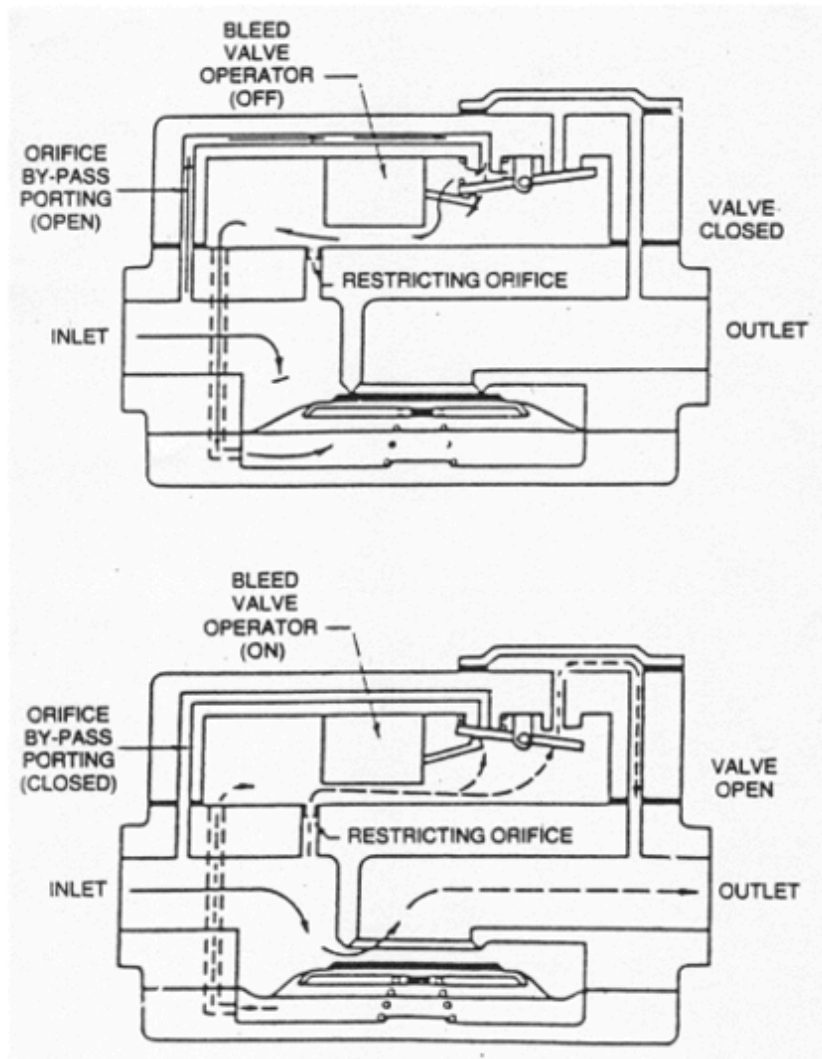
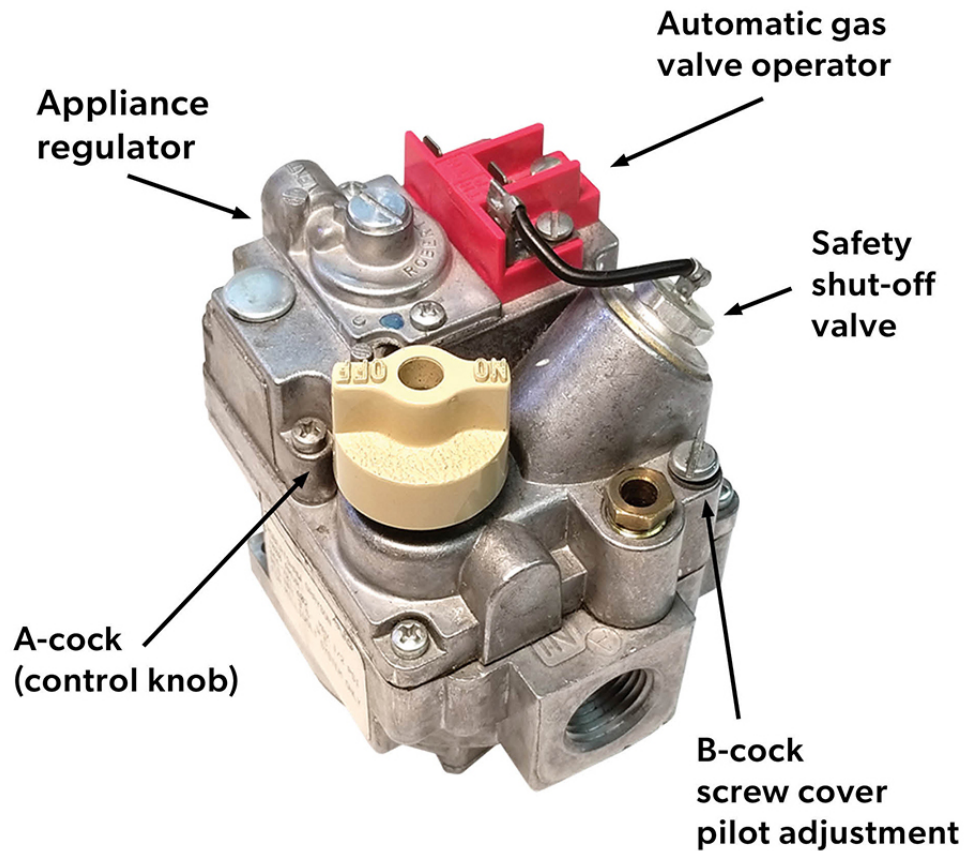

Figure 47. Internal bleed diaphragm gas valve

### Combination gas valves

Combination gas valves will combine some or all of the valve train components into one unit. It is common for combination gas valves designed for less than 400 MBH/120 kW to include all of valve train components in the one valve body (Figure 48).



*Figure 48. Millivolt combination gas valve*

For larger inputs the combination gas valve may just combine a couple of components such as the automatic operating valve and regulator. The 1" regulating diaphragm gas valve shown in Figure 49 can be used for main burners rated for up to 1 000 MBH. It is a slow opening valve that controls the on-off flow of gas to the main burner as well as regulating the manifold gas pressure to 3.5 " wc.



*Figure 49. 1” Combination regulating diaphragm gas valve*

### **Regulating diaphragm gas valve operation**

The regulating diaphragm gas valve is also known as a Servo gas valve as it has a small servo pilot regulator to position the diaphragm seat. The Servo gas valve uses the same principle as the diaphragm gas valve, in that it manipulates a small amount of upstream gas pressure into the working chamber of a diaphragm. Whereas the diaphragm valve was strictly an open or closed valve the servo gas valve can also act as a pressure regulator by partially opening or closing the main valve seat.

### **The stages of operation:**

When the controller is not calling for heat (Figure 50), the bleed valve solenoid coil is not energized. The plunger in the actuator is in the down position, blocking the bleed vent. Inlet gas pressure passes through the restrictor and down the bleed line to build pressure under the main valve diaphragm. The gas pressure is equal above and below the diaphragm. The force of the spring and the fact that the area of the lower diaphragm surface is greater keep the valve closed.

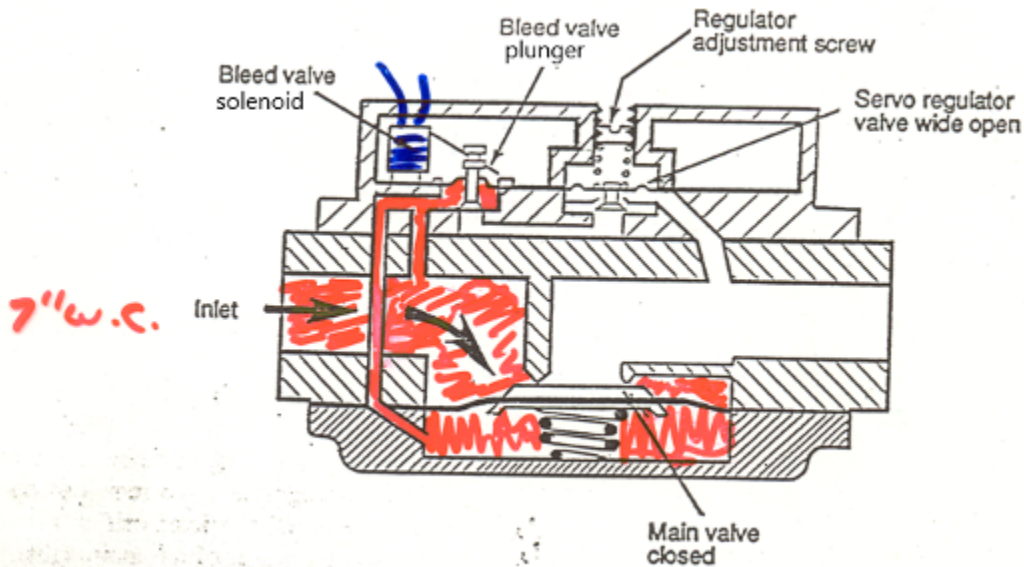

Figure 50. Servo diaphragm valve closed

On a call for heat, the bleed-solenoid is energized and lifts the bleed valve plunger (Figure 51). Gas under the main diaphragm evacuates through the bleed line and valve and on through the open servo regulator to the outlet of the main valve. The gas pressure on the top of the main diaphragm now overcomes the effects of the spring and the reduced gas pressure under the diaphragm and the main valve opens. (Note that the gas can be bled out faster through the servo regulator opening than it can enter through the small restrictor orifice or the lower chamber would not bleed.)

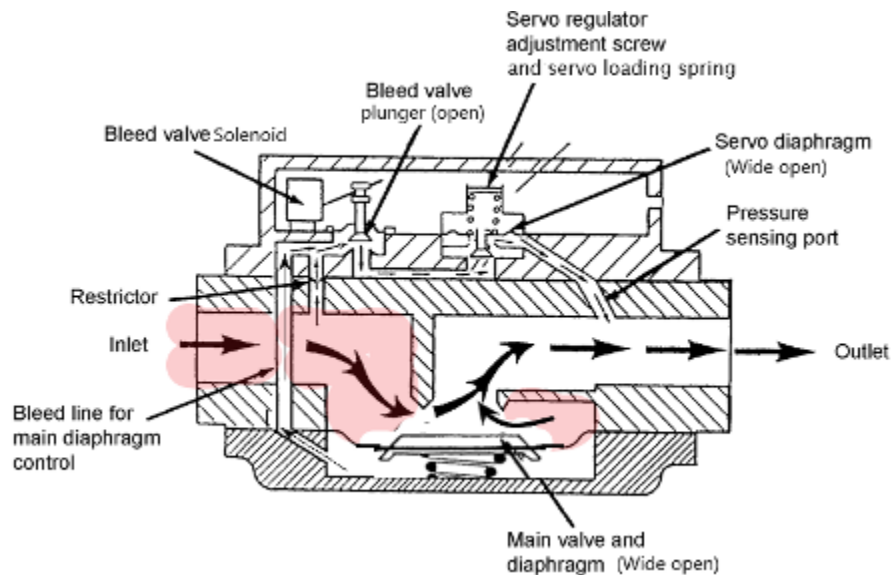

Figure 51. Servo diaphragm valve wide open

As the pressure increases at the outlet of the main valve, it is transmitted through the pressure-sensing port to the lower side of the servo regulator diaphragm (Figure 52). This rise in pressure causes the servo regulator to compress the servo loading spring. The servo disk moves upward and the flow of bleed gas to the main valve outlet is now restricted. This increases the pressure in the working gas

pressure chamber and raises the main valve towards its seat, decreasing the flow rate. The servo regulator continues to sense the main valve outlet pressure and then controls the bleed rate to create a working gas pressure that will hold the main valve disk in a position that will match the required flow rate at the required setpoint pressure.

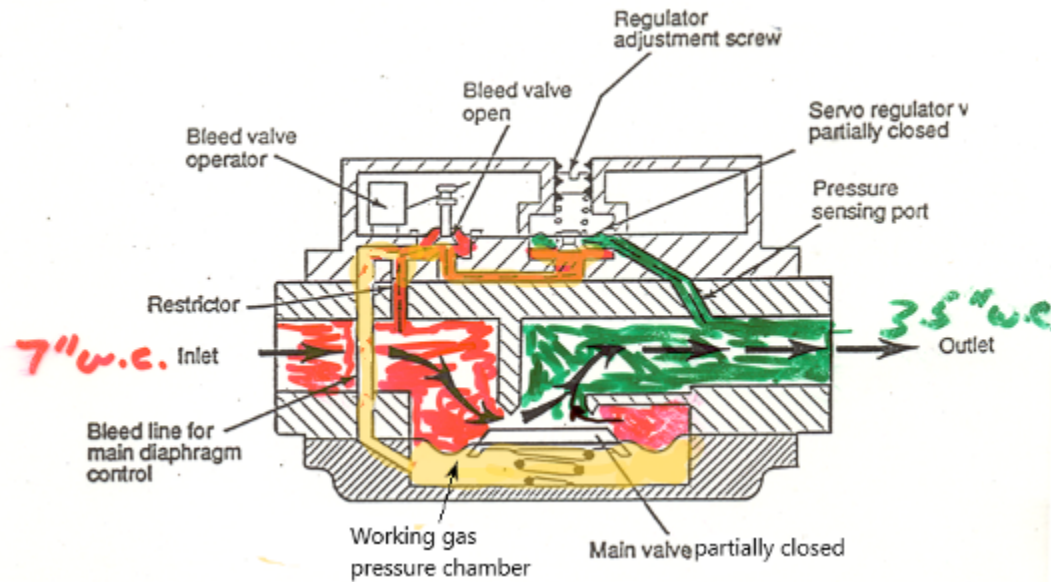

Figure 52. Servo diaphragm valve throttling

After the controller is satisfied, or if there was a power outage, the solenoid coil is de-energized and the valve returns to the closed position shown in figure 50.

The previous diagrams have been created for explanation purposes. The arrangement of the internal components and the direction of movement will vary when you are looking at a manufacturer's cutaway diagrams (Figure 53) but the concept of using a small servo operated pilot regulator to position the main valve seat is consistent. Notice that the safety shutoff valve has now been included as the first internal valve. This cutaway represents the inner working of a valve similar to the previous picture shown in Figure 49. Just like any other regulator, the small servo regulator has a bleed vent above the diaphragm to allow the free movement of air to and from the upper diaphragm chamber. Because these valves are installed indoors the vent has a built-in restricting orifice to limit the amount of gas that would escape in the event of a rupture of the servo regulator diaphragm.

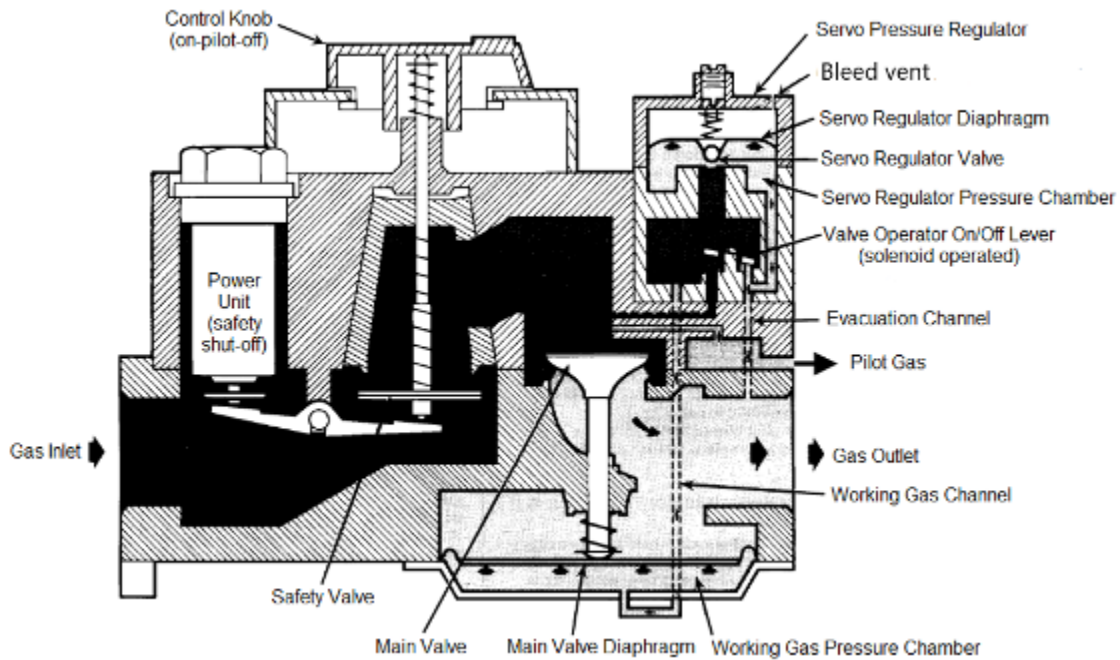

Figure 53. Combination servo gas valve [\[Image Description\]](#)

### Redundant gas valves

Since 1979 all heating combination gas valves have been required to be dual seated valves, or on millivolt systems have an extra limit that disconnects the valves power supply. To accomplish this combination gas valves will have a second automatic shut-off valve incorporated into the valve body. This second (redundant) valve gives an extra level of protection against gas entering the combustion chamber if the main valve seat were to leak while in the closed position.

The redundant gas valve is also a diaphragm style servo regulated valve similar to the previous Figure 53. When you compare to Figure 54 you can see that the redundant valve coil uses a 24 VAC solenoid actuator rather than the 30 millivolt safety shut-off valve shown in Figure 53.

When set up to operate with an intermittent pilot, the following sequence of events occur:

1. With no voltage applied to the valve both the main and pilot valves are in the closed position and the gas is being held at the inlet port by the pilot valve.
2. The controller calls for heat and after a pre-purge period the pilot coil is energized and opens the pilot valve. The pilot gas uses the valve inlet pressure and it is not regulated, instead it can be throttled with an internal needle valve that is not shown.
3. Gas is delivered to the pilot burner where it is ignited by spark igniter. Once the pilot flame is proved, by a flame detection circuit, the spark igniter is de-energized.
4. The pilot flame is confirmed and monitored, then the main valve coil is energized allowing gas to flow through an internal channel into the working gas pressure chamber on the underside of the diaphragm forcing the main valve open and gas flows to the main burner where it is ignited by the pilot burner.

5. The servo regulator senses the main valve outlet pressure and then controls the servo bleed rate to create a working gas pressure that will hold the main valve disk in a position that will match the required flow rate and setpoint pressure.
6. When the call for heat is satisfied the controller opens its contacts and both the pilot valve and the main valve solenoids are de-energized and the flow all gas stops.

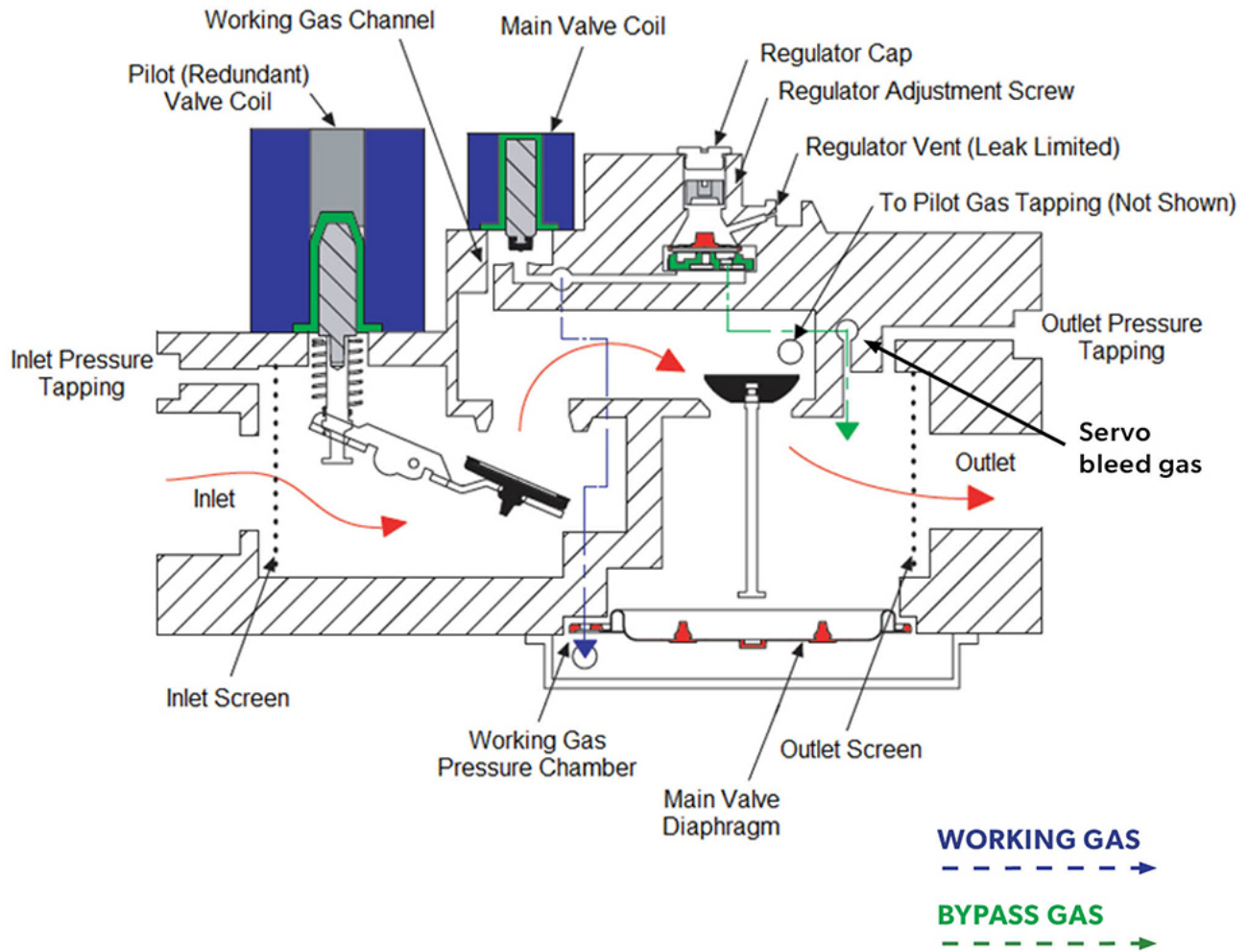

Figure 54. Redundant gas valve internal flow

The valve may also be set up to operate with an electronic ignition system that lights the main burner directly without the use of a pilot flame. When used on a main burner HSI or DSI systems a wiring harness is used to energize both the pilot and main valve operators simultaneously. There will also be a threaded plug installed in the pilot line connection (Figure 55).

Regulator bleed vent cover shown in the picture serves as a dust cover only as the leak limiting orifice is internally built into the vent opening.

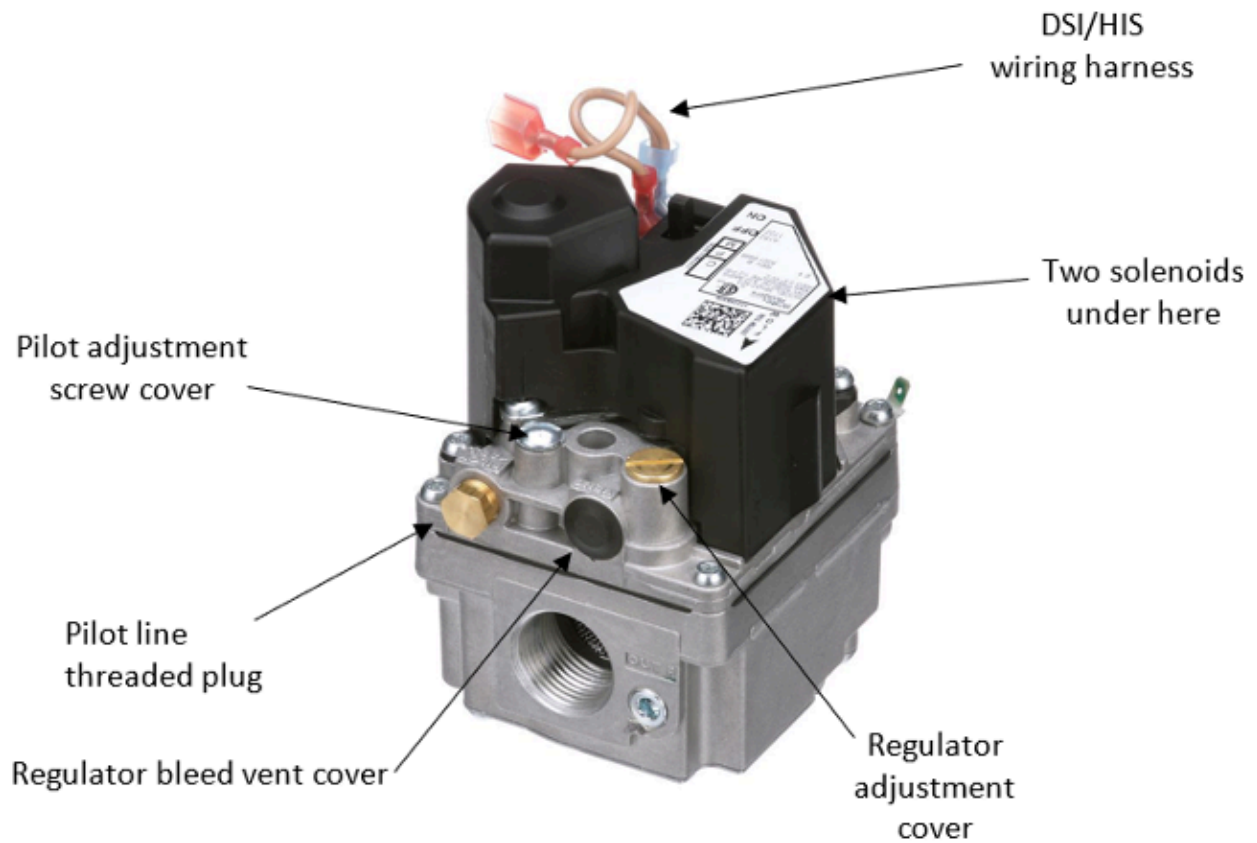

Figure 55. Universal combination redundant gas valves

For some styles of redundant gas valves, used only on Direct ignition systems (DSI/HSI), the two operators are internally wired together and there is no pilot tapping (Figure 56). This valve has also been designed to be very compact. Notice the regulating valve's large diagram chamber visible on the side of this valve.



*Figure 56. Compact direct ignition gas valve*

Additionally, because there is no pilot gas requirement, both the main and redundant valve seats are combined into one double seated solenoid valve (Figure 57). The regulating valve is held closed until the main valve seat sends gas pressure to the underside of the diaphragm via the working gas orifice and passages (not all shown). The working gas pressure is then controlled by the servo regulator to position the regulating valve.

1. Valve solenoid
2. Pressure tap inlet
3. Redundant valve
4. Main valve
5. Supply inlet
6. Diaphragm
7. Regulator valve
8. Main burner outlet
9. Servo regulator
10. Regulator adjust screw
11. Pressure tap outlet
12. Working gas orifices

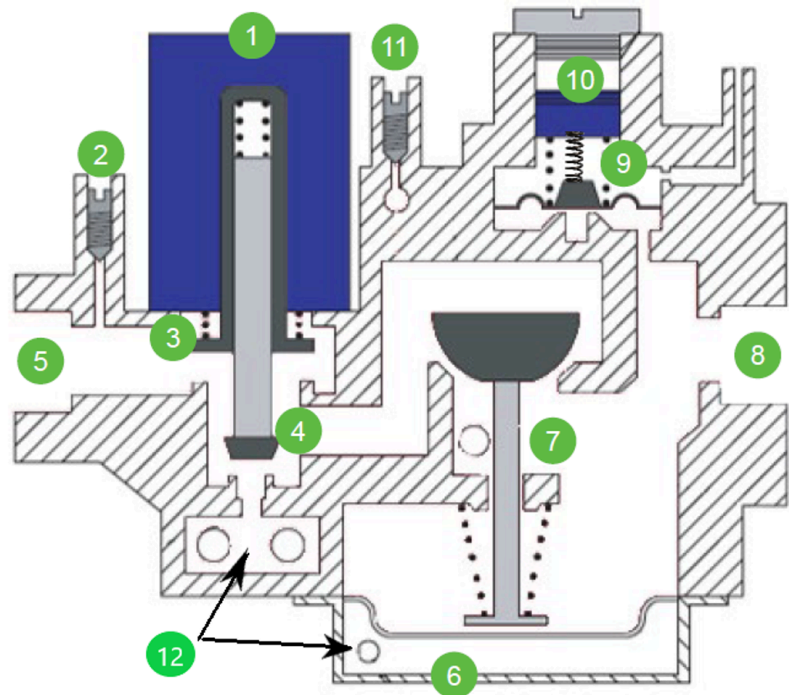

Figure 57. Double seated redundant gas valve internal flow. [\[Image Description\]](#)

#### Referenced servo regulator pressure

Many modern appliances are fine tuned to adjust to changing conditions while still delivering accurate gas pressure to the combustion chamber. To look at such a valve, it is important to understand the pressure drop across a burner orifice is determined by the manifold pressure of the appliance. It is normally the difference between the manifold pressure and the atmospheric pressure surrounding the orifice outlet.

For most high efficiency gas furnaces the combustion air is drawn into the appliance by an induced draft fan and the combustion chamber will experience a non-atmospheric pressure condition, in this case negative or vacuum (Figure 58). This would change the pressure differential across the gas orifice and alter the gas flow to the burners. The manifold pressure must equal the required orifice  $\Delta P$  plus the combustion chamber pressure. For example, if the orifice was sized for a pressure differential  $\Delta P$  of 4" wc and the combustion chamber had a negative pressure (vacuum) of 1" wc, then the servo regulator would need to be adjusted down to 3" wc to maintain the correct gas input ( $\Delta P$  4" + (-1") = 3").

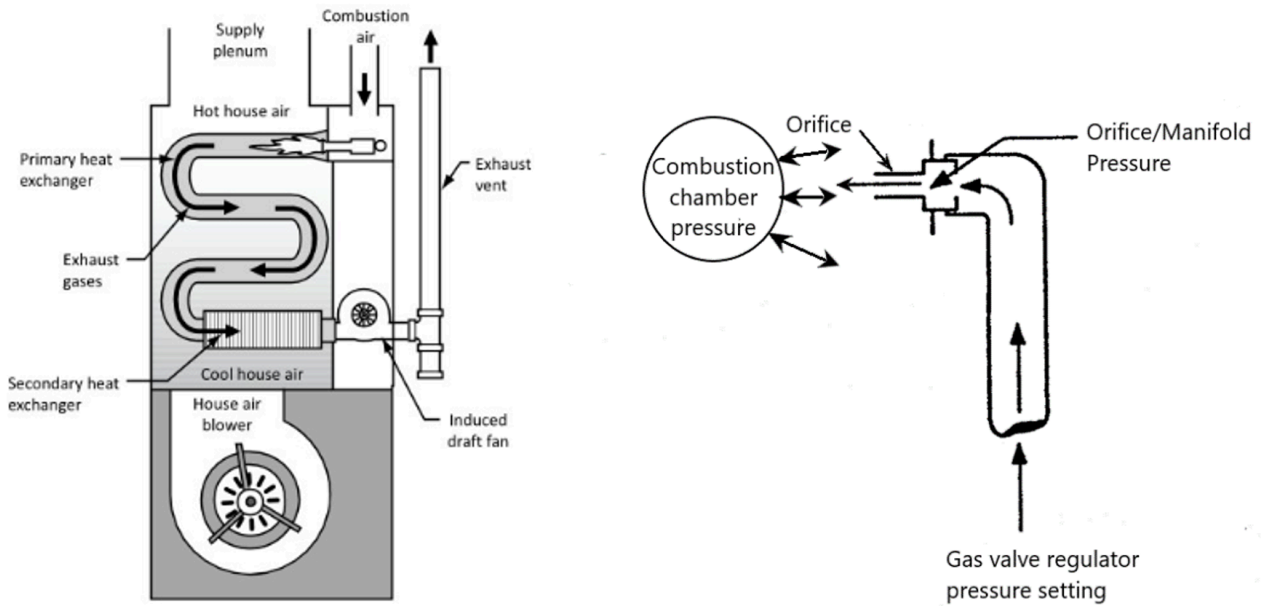

Figure 58. Sealed combustion chamber pressures

Every installation will have different vent configurations which could result in different effects on the amount of combustion chamber vacuum. Additionally, there will be fluctuations for changing barometric conditions. By connecting a combustion chamber pressure compensation tube to the regulator bleed vent opening of the gas valves servo regulator, the combustion chamber negative pressure is applied to the loading element side of the regulator diaphragm (Figure 59). This will enable the regulator to automatically change the manifold pressure and maintain a constant pressure differential across the orifice. The compensated manifold pressure is often referred to as *referenced manifold pressure*. Notice that there are also two pressure switches connected to the reference tube as part of the ignition safety controls to verify the fan is operating properly.

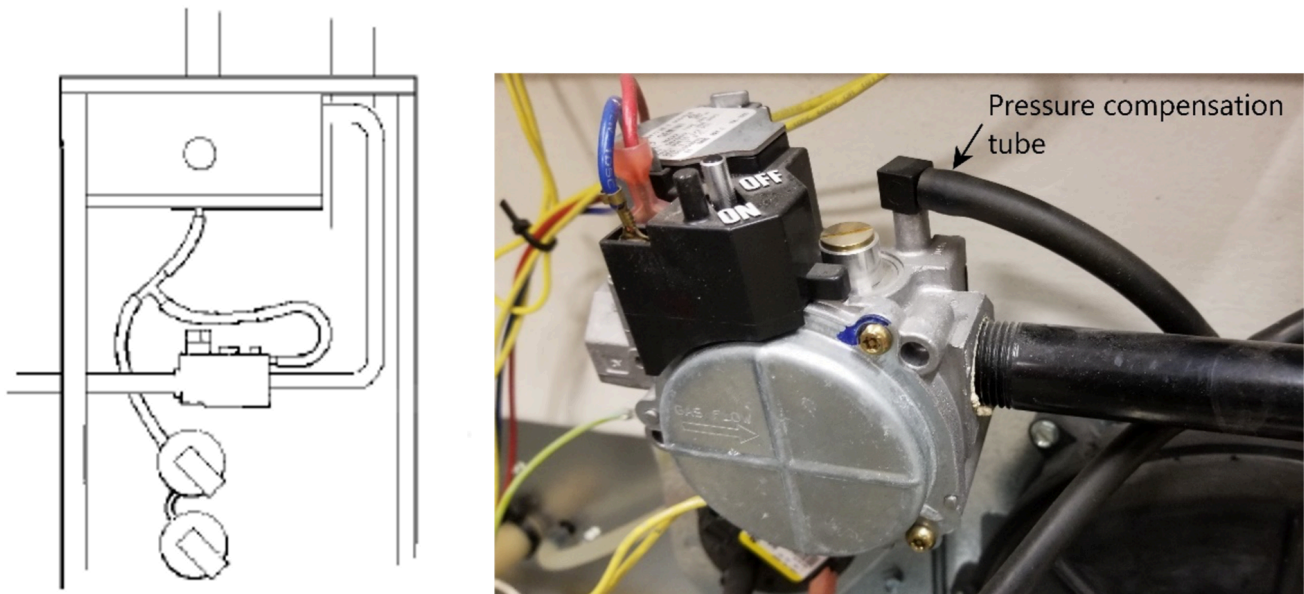

Figure 59. Combustion chamber reference tube

## Staged and modulating combination gas valves

For high efficiency condensing appliances it is important to try and match the firing rate to the systems heat demand. Reducing the gas input during low load conditions will ensure the appliance achieves maximum efficiency. There are a number of different approaches used to changing the appliance input that depend on the type of appliance and how much variation is needed. The two most common variable input schemes include:

- Multistage input
- Full modulating input

### Multistage input

Multistage heat production divides the total heating output into a number of increments, or stages. As the load increases, the stages are turned on sequentially. Multistage input has been used for many years on commercial heating plants by splitting the total building load into multiple modulating boilers.

Residential forced air furnaces are often two stage (dual stage). The lower input allows the unit to conserve energy and reduced temperature fluctuations by operating more continuously. Most of the time, the furnace will run at low fire. If outdoor temperature drops drastically, the furnace can use its high fire mode to maintain the desired building temperature.

A two-stage gas valve is used with a two-stage thermostat to supply fuel in quantities necessary to meet the staged demand (Figure 60). The valve has two servo regulators, to enable it to supply lower manifold pressure and less fuel on a first-stage heating call. When the second stage is energized, the high-fire pressure servo-regulator is activated and 100% fuel flow is sent to the burner. Notice this valve body is very similar to one of the previous images with an extra servo regulator adjustment cover and an additional wiring connection to activate the servo switching solenoid valve. Typical pressure ranges are: low-fire 1-1.5 in. WC; high-fire 3-4 in. WC.

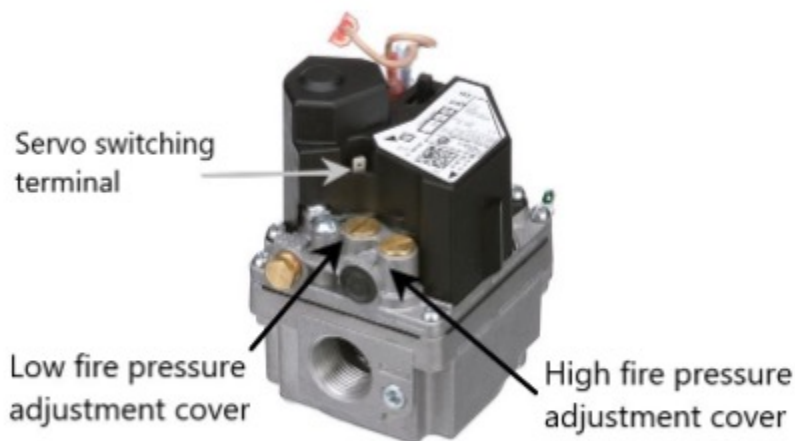

Figure 60. Two stage redundant gas valve

### Modulating input

A gas burner's turndown ratio is the ratio of maximum heat output to the minimum level of heat output at which the appliance will operate efficiently or controllably. A fully modulating burner controller will alter the firing rate to match the load over the whole turndown ratio. For example, a 100 000 Btuh modulating condensing boiler with a 10:1 turndown ratio could supply a load range from 100 000 to 10 000 Btuh and any point in between.

During this process, the gas burner must stay at the correct fuel-to-air ratio across the complete firing range to ensure the maximum combustion and boiler efficiency. This task is performed by an electronic controller which analyses number of different operating parameters to determine the correct firing rate.

Gas appliance manufacturers typically take one of two approaches to pressure modulation by a combination gas valve:

- Zero governor/ratio regulation.
- Modulating electric actuators

#### Zero governor/ratio modulation

The concept of venturi mixers and zero governor regulation was previously introduced in Learning Task 3. In this case the modulating mechanical mixing burner uses a variable speed blower to adjust the combustion air flow. In order to maintain proportional mixing the zero governor servo regulator, within a combination gas valve, automatically changes the gas flow to match the air flow. These flow adjustments are dependent upon the amount of vacuum generated by the air velocity flowing through the venturi (Figure 61). Remember the zero governor servo regulator is trying to maintain atmospheric pressure at P2. Just like all other servo regulators it will use the supply pressure to create the necessary working pressure onto the working diaphragm that will position the operating valve as needed.

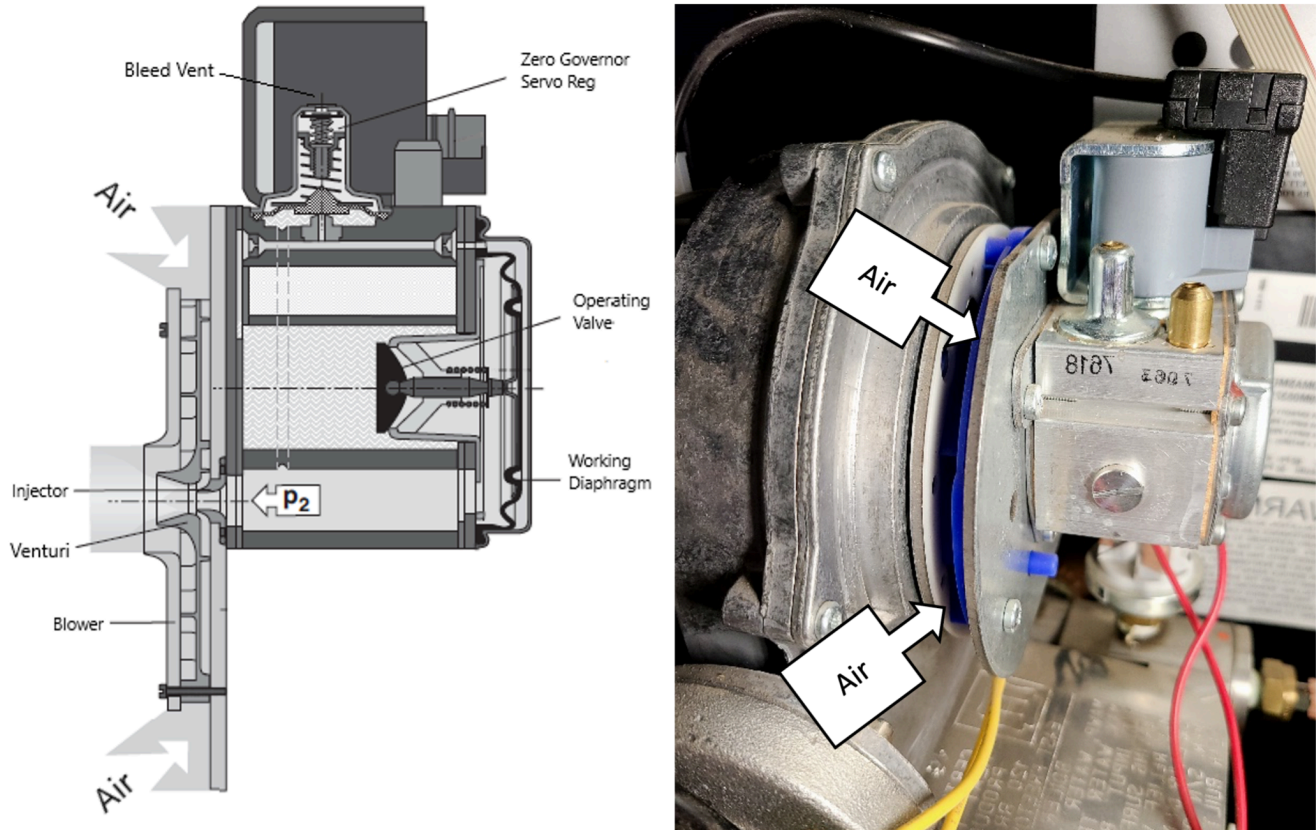
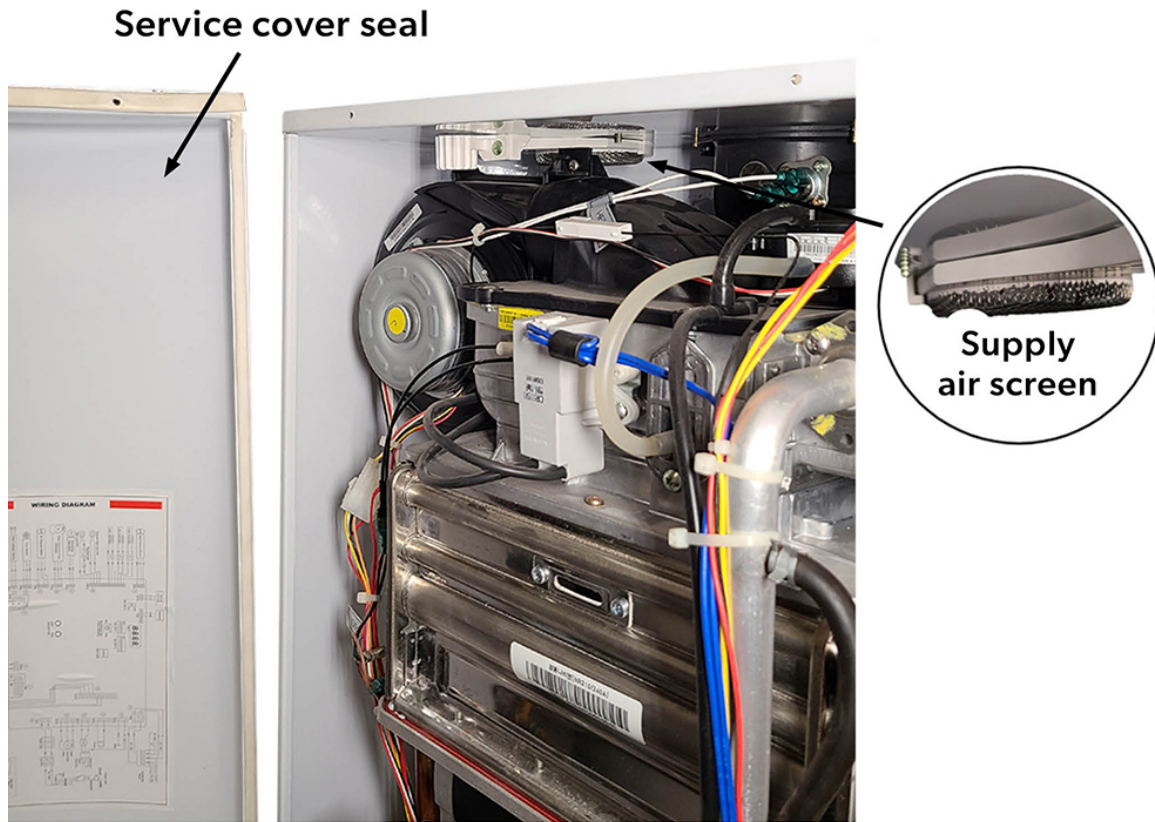

Figure 61. Modulating venturi burner

As was previously explained zero governor regulators control the outlet pressure with a goal of zero pressure, relative to atmosphere. They allow the flow of gas to only occur when a negative pressure is sensed at the injector, which is conveyed to the underside of the servo regulator diaphragm. The upper side of the servo regulator diaphragm bleed vent is sensing ambient air pressure. For direct vent appliances the air supply shown in Figure 64 is supplied through a pipe. This pipe creates some resistance to the blower suction; therefore, the air being supplied to the venturi will already be at a slight negative pressure. It is important that the regulator does not interpret this additional negative pressure at the injector as being generated by the venturi and add too much gas. As long as the bleed vent is also sensing the negative supply air pressure onto the upper side of the diaphragm it will cancel out the air supply negative, and only sense the vacuum created by the venturi velocity.

For many small, wall-hung boilers and on-demand water heaters (Figure 62) the air supply pipe is only connected to the appliance cabinet. The service cover has a seal to separate the combustion air supply from the room, essentially making the cabinet an air supply duct for the blower inlet. Therefore, the bleed vent of the zero governor servo regulator, also located within the housing, is sensing the same pressure as the blower inlet.



*Figure 62. Air supply connection*

On some modulating venturi mixing burners the air supply pipe is connected directly to the blower inlet (Figure 63). In these cases, a pressure compensation tube will be connected upstream of the venturi to the bleed vent of the zero governor servo regulator. This will neutralize the negative pressure created by the resistance of the air supply piping.

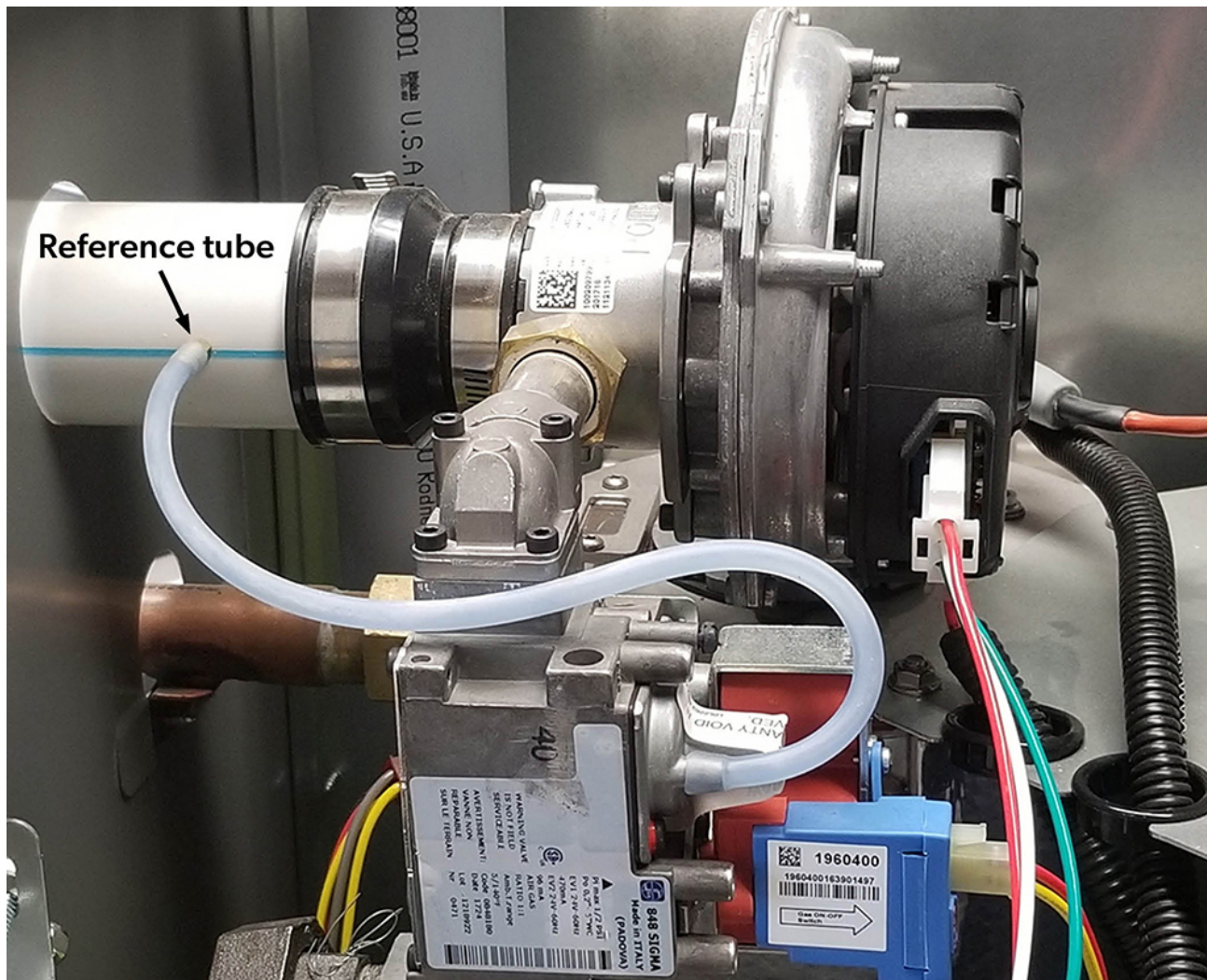

Figure 63. Zero governor reference tube

#### Modulating electric actuators

Another approach to gas valve, pressure modulation is to replace the servo regulators adjustment screw and spring with an electric actuator. Modulating electric actuators have an internal system that positions the output shaft proportional to an input control signal. Unlike on-off electric actuators, modulating actuators do not necessarily travel the full span from open to close in one movement, but move only according to the change in the input control signal. Typically, the analogue control input signal is 0-10VDC, or 4-20mA. The proportional positioning is set by the input signal, say 0-10V where 0V is closed and 10V is open, 5V is 50% open. Therefore, the actuator can vary the manifold pressure setting from low to high-fire pressure, or any point in between based upon the signal from the controller. The controller will constantly monitor the outlet pressure and other system feedback sensors to adjust the servo regulator setting. There are two types of electric positioning actuators used on combination gas valves, to adjust the servo regulator loading force.

- Modulating solenoid actuators
- Stepper motor actuators

The servo regulator portion of a combination diaphragm gas valve shown in Figure 64 has a modulating solenoid actuator. Notice there are adjustable maximum and minimum pressure stops. The image shows the solenoid is holding the output shaft approximately midway of its full travel range. This position adjusts the spring force to about 50% of its pressure setpoint range. Some appliances will adjust the maximum pressure setting with a potentiometer on the controller to limit the control signal output at high fire.

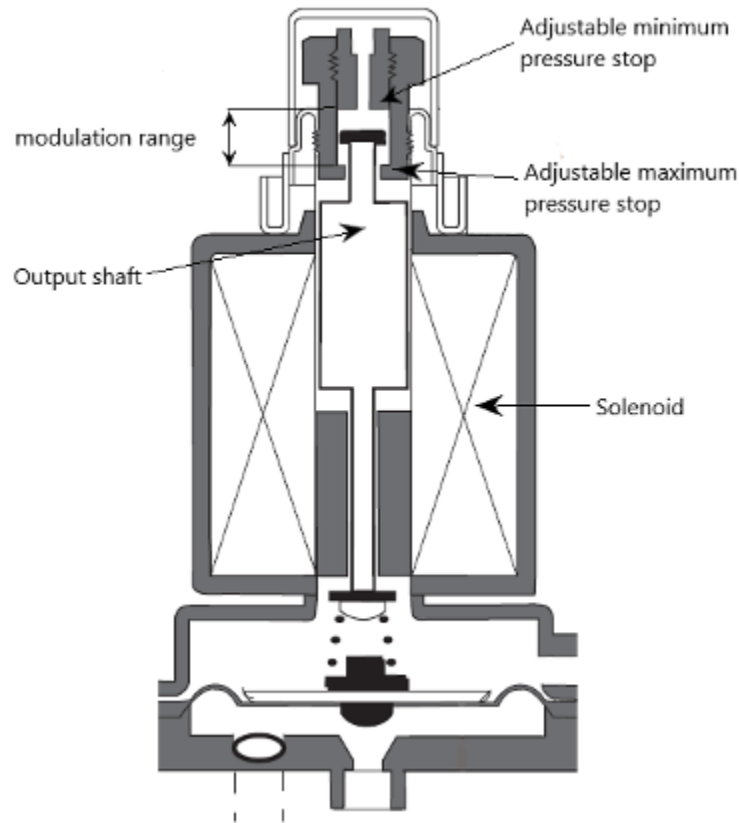

Figure 64. Modulating solenoid servo regulator

The use of a stepper motor is another common method of modulating the servo regulator setting. A rotating DC motor operator is used to turn the pressure adjustment screw to the desired setting. For example, the valve shown in Figure 65 has the same body and internals as a redundant gas valves previously introduced in Figure 56 and 57 with the addition of the DC stepper motor operator. These valves can achieve a full range of modulation from 35–100% with 1% increments. Notice the stepper motor rotates a threaded spindle which moves the adjustment nut up or down to change the gas pressure setting.

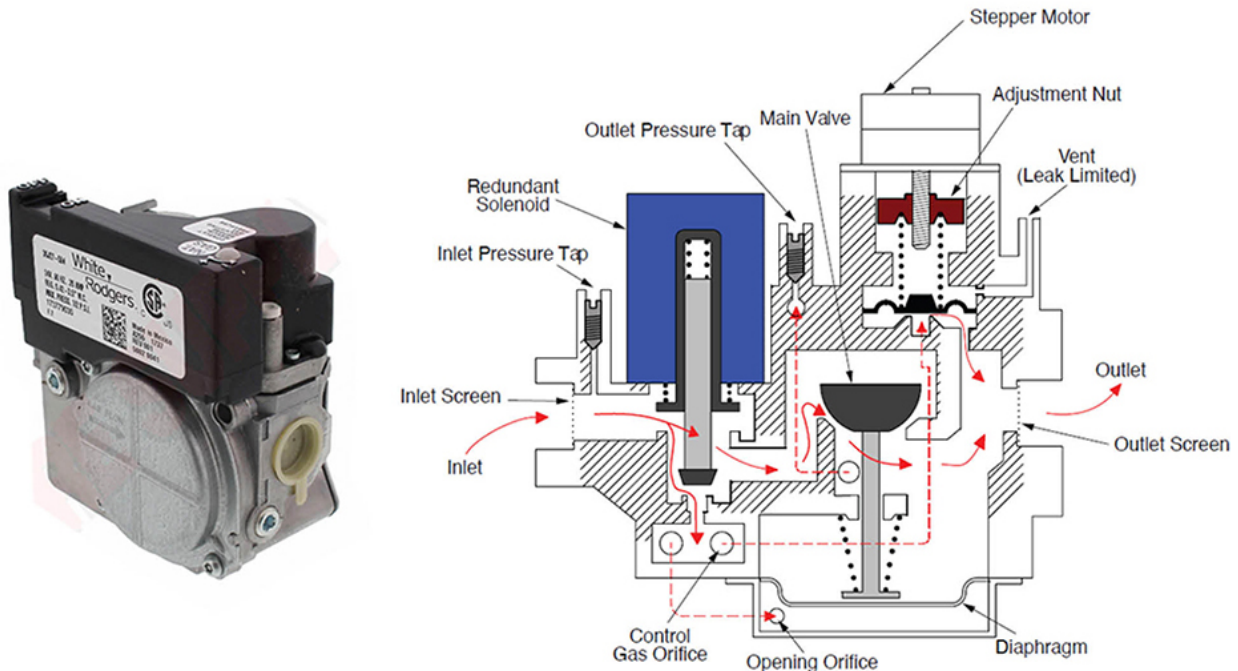

Figure 65. Stepper Combination Gas Valve

### Self energized automatic gas valves

Self energized gas control valves have solenoids that operate with 750 mV supplied from a thermopile heated by the pilot flame. Notice the power supply wiring connections on the combination valve in Figure 66 are labeled TP for Thermopile. Other manufacturers will also use the abbreviations PP (powerpile) or PG (pilot generator). This valve has a separate thermocouple connection which is necessary configuration for direct vent appliances that require a fast-acting flame failure response. There is also a manual main burner adjustment dial which is essentially an extension of the servo regulator adjustment screw. The pilot flame pressure is not regulated and has a separate adjustable needle valve.

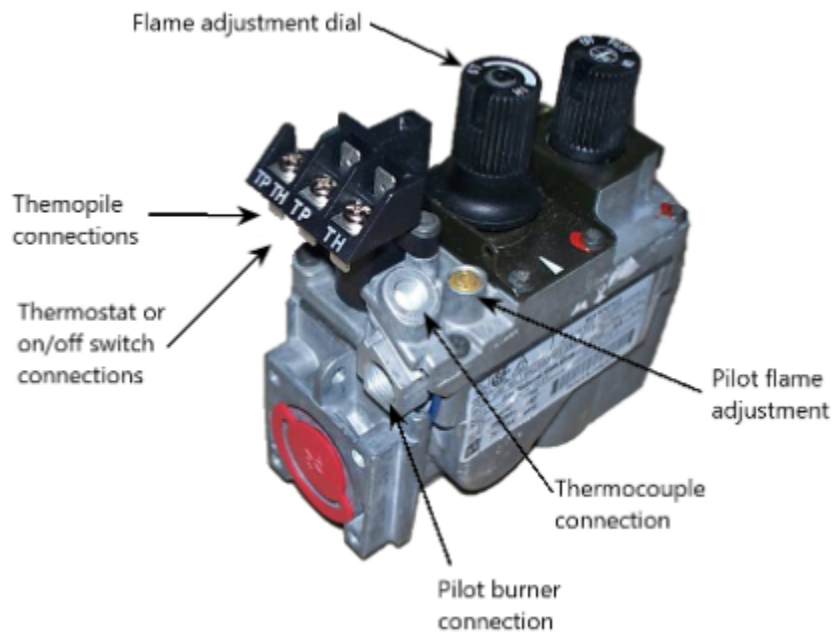

Figure 66. Millivolt combination gas valve

The pilot burner for this valve uses a split pilot flame with a quick response thermocouple to energize the safety shut-off and a thermopile to power the main valve (Figure 67). On unvented gas heaters this same quick response thermocouple set up is used with a special ODS pilot burner (Oxygen Depletion Sensor). If the oxygen content in the room drops the pilot flame actually lifts off the thermocouple cooling it down and causing the gas valve to close and the heater to shut off.

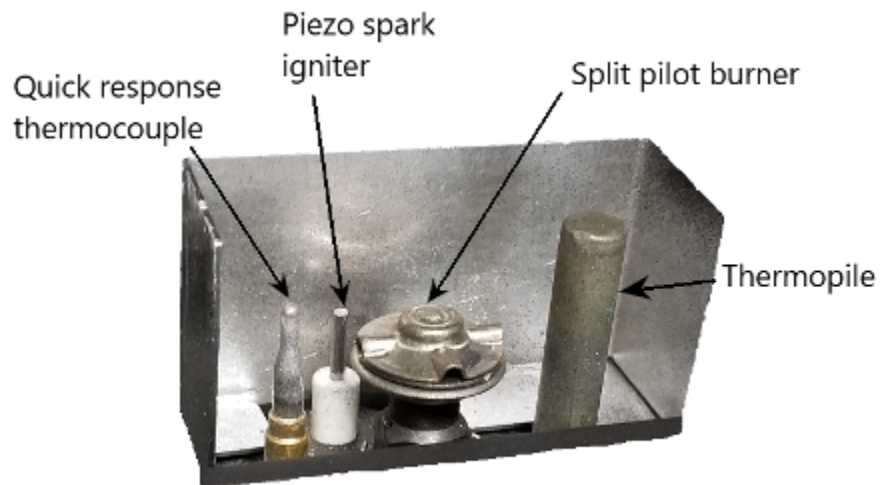

Figure 67. Millivolt pilot burner

Another configuration of a millivolt gas valve uses the thermopile to energizes both the pilot safety and the main valve circuits. You can see in Figure 68 that both the pilot valve and the main valve are wired in parallel to the Thermopile (TP). The thermostat (TH) will only turn on/off the main valve.

Because it takes longer for a thermopile to cool off and shut off the pilot valve these are only used on gravity vented appliances that do not require rapid shut-off in the event of flame failure.

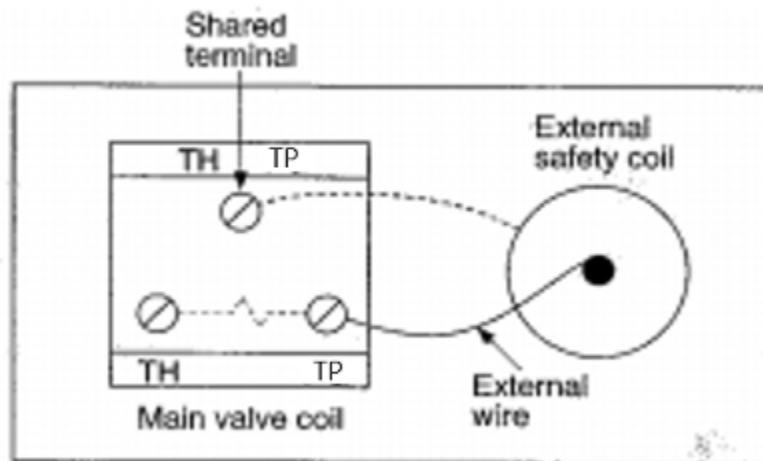

Figure 68. Millivolt gas valve wiring connections

### Battery operated gas valve

To meet efficiency standards continuous pilot fireplaces are being phased out in favour of DC low voltage electronic ignition systems, which use common dry cell batteries as the power source. The receiver/control module will have a compartment in which to install four AA batteries or a separate battery holder that plugs into the module (Figure 69).



Figure 69. Battery operated fireplace control system

All components of the control circuit will be from the same manufacturer, designed to work with each other on 6 VDC. These systems can include options to modulate flame height and heat output as part of the temperature control system.

## Storage type water heater gas valves

Similar to previously introduced combination gas valves, the control valves for a storage water heaters have multiple components within a single control. Depending on the style of gas valve, some of the safety and operational functions may include:

- Manual shutoff
- Pressure regulator
- Pilot adjustment screw
- Safety shut off control
- Water temperature control
- High limit energy cut-off (ECO)
- Combustion chamber thermal cut-off (TCO)
- Flammable vapour ignition resistance (FVIR)

For most types of storage water heater gas valves, the body of the valve contains a water temperature sensor (aquastat) contained in an immersion well. The entire valve then gets threaded into an opening in the side of the tank to mount the valve and immerse the sensor into the water.

Storage water heater control valves can be put into two categories, as either standing pilot or intermittent pilot. Another common grouping is non-electric (rod and tube) or electric.

### Standing pilot types

Standing pilot, storage water heater gas valves are of two types: non-electric (rod and tube) or self energized (millivolt). One of the advantages of conventional standing pilot storage water heaters is that they can produce hot water during a power outage.

Standing pilot types (Unitrol) will require a pilot burner assembly complete with a thermocouple or thermopile and a pilot piezo igniter (Figure 70). If the pilot flame is extinguished for any reason the internal pilot safety shutoff valve will be deenergized and shut off.

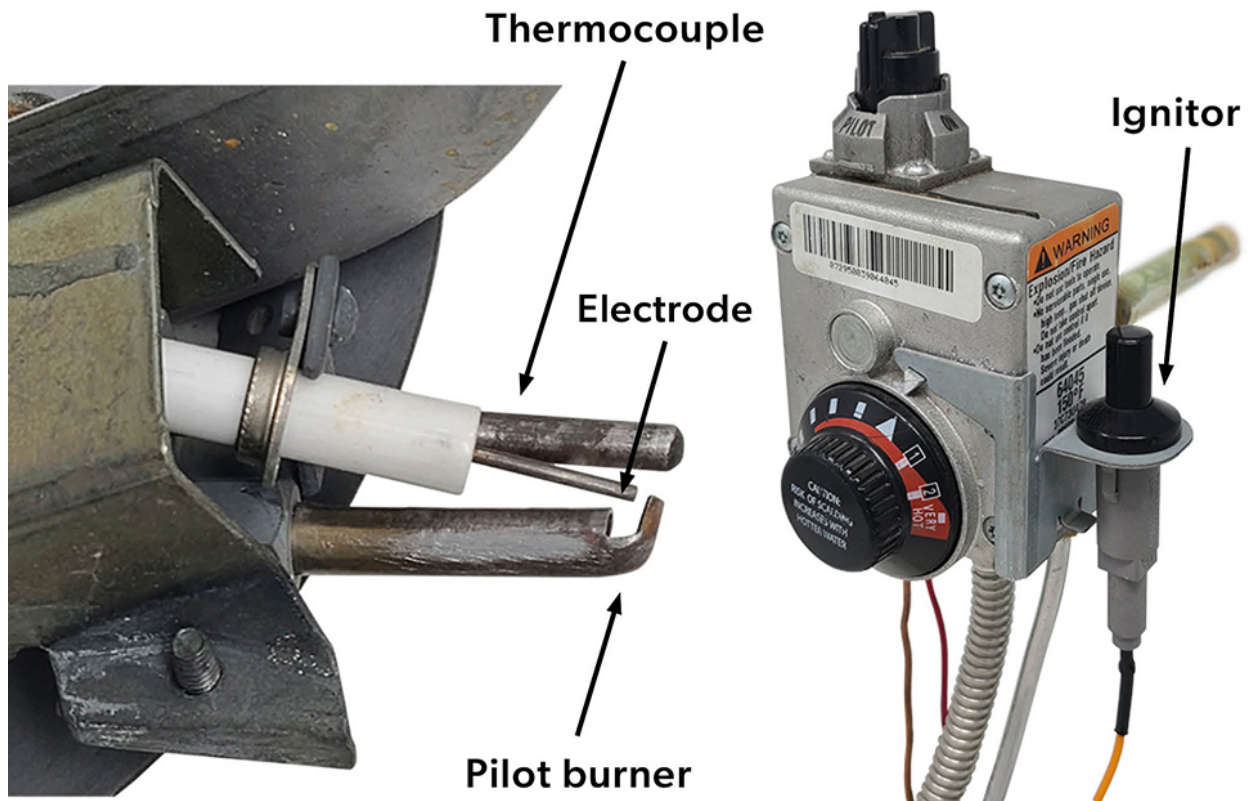
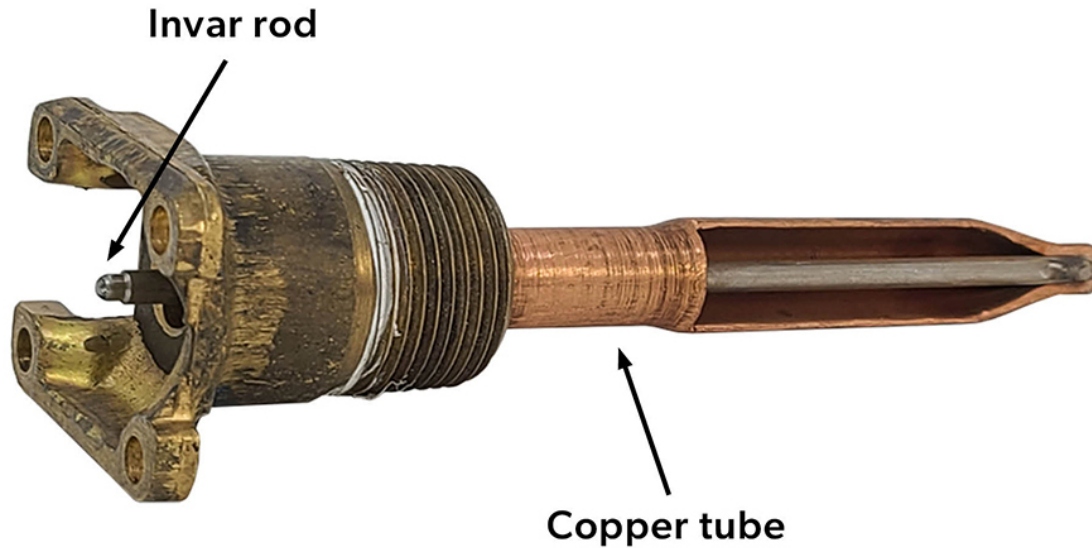

Figure 70. Standing pilot non-electric storage water heater gas valve components

#### Non-electric rod and tube gas valves

On the rod and tube gas valve the main burner is activated by a thermal mechanical sensor made up of a copper tube and invar rod assembly. In Figure 71 the edge of the copper tube has been ground away to expose the internal rod. The copper tube has high expansion and contraction rate, whereas the encased rod is made of a metal alloy called invar which has a very low expansion and contraction rate. The rod and tube are only connected together at the immersed end so temperature changes of the water cause the copper tube to expand and contract, forcing the control end of the Invar rod to move in and out of the valve body.



*Figure 71. Rod and tube temperature sensor*

The upper diagram of Figure 72 shows the valve in the closed position so the main burner is off. As the water in the storage tank cools the copper tube will contract and end of the invar rod pushes on the lever slowly moving the clicker snap mechanism. The lower diagram of Figure 72 shows that once the internal disc has moved past its center the clicker opens the gas valve and gas flows to the main burner. Typically, the stored water drops about 8°C (15°F) to 11°C (20°F) from the temperature setpoint before the burner is activated.

Upon heating, the copper tube expands and moves the invar rod to the right away from the valve. This allows the clicker mechanism to return to its normal position and the valve spring to close the valve. The temperature dial position determines the maximum thermostatically controlled water temperature sensed by the copper tube. Rotating the temperature dial moves the adjustment rod in or out, changing the lever position and the temperature at which the invar rod activates the clicker mechanism.

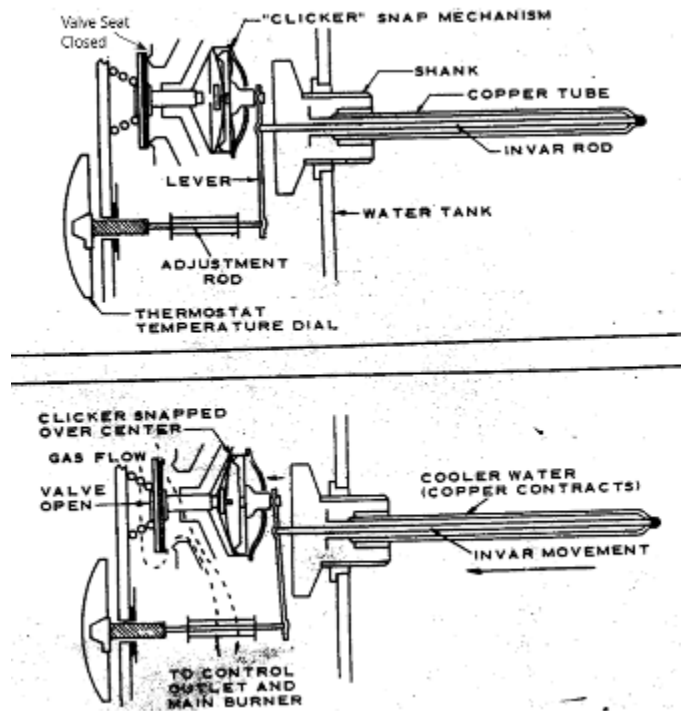

Figure 72. Rod and Tube operation

#### Water high limit energy cut-off (ECO)

An *energy cut-off* (ECO) device is a safety limit used on rod and tube gas control valves. The ECO is a temperature-sensitive fusible link wired in series between the thermocouple and the pilotstat, so the 30mV produced by the thermocouple passes through it on its way to the pilotstat coil. In Figure 73 the copper tube has been cut to expose the fuse located alongside the invar rod.

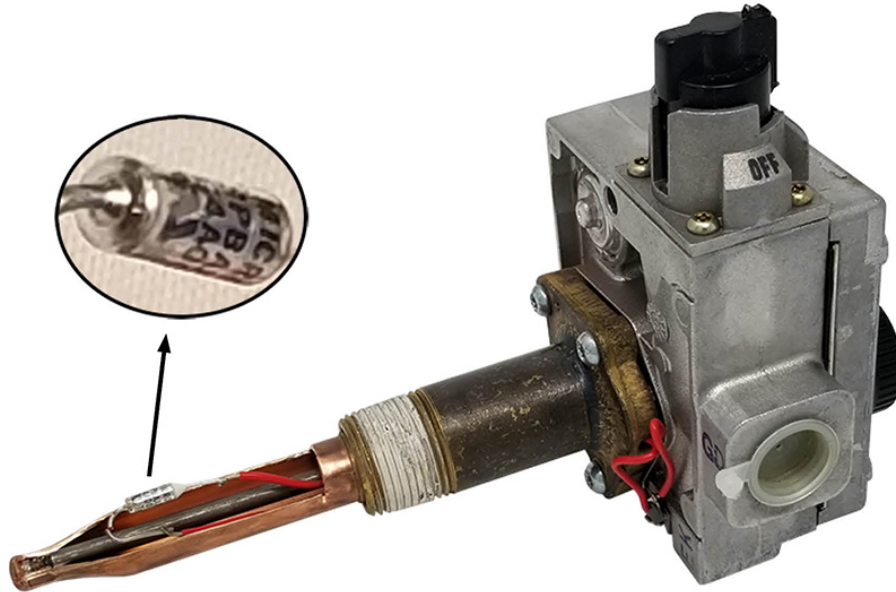

Figure 73. ECO cutaway

If there is a gas valve failure that causes the water temperature to exceed 93°C (200°F), the ECO will melt, breaking the safety circuit, and shutting off gas flow to the burners. The ECO is a single use safety switch and requires the replacement of the entire gas valve to put the water heater back into service.

#### Combustion chamber thermal cut-off (TCO)

The storage water heater safety system also includes a manual resettable, safety switch which is designed to disable the gas control/thermostat in the event of excessive combustion chamber temperatures. The *thermal cut-off* (TCO) is mounted into the inner sealed combustion chamber cover door and wired in series into the safety circuit with the ECO (Figure 74).

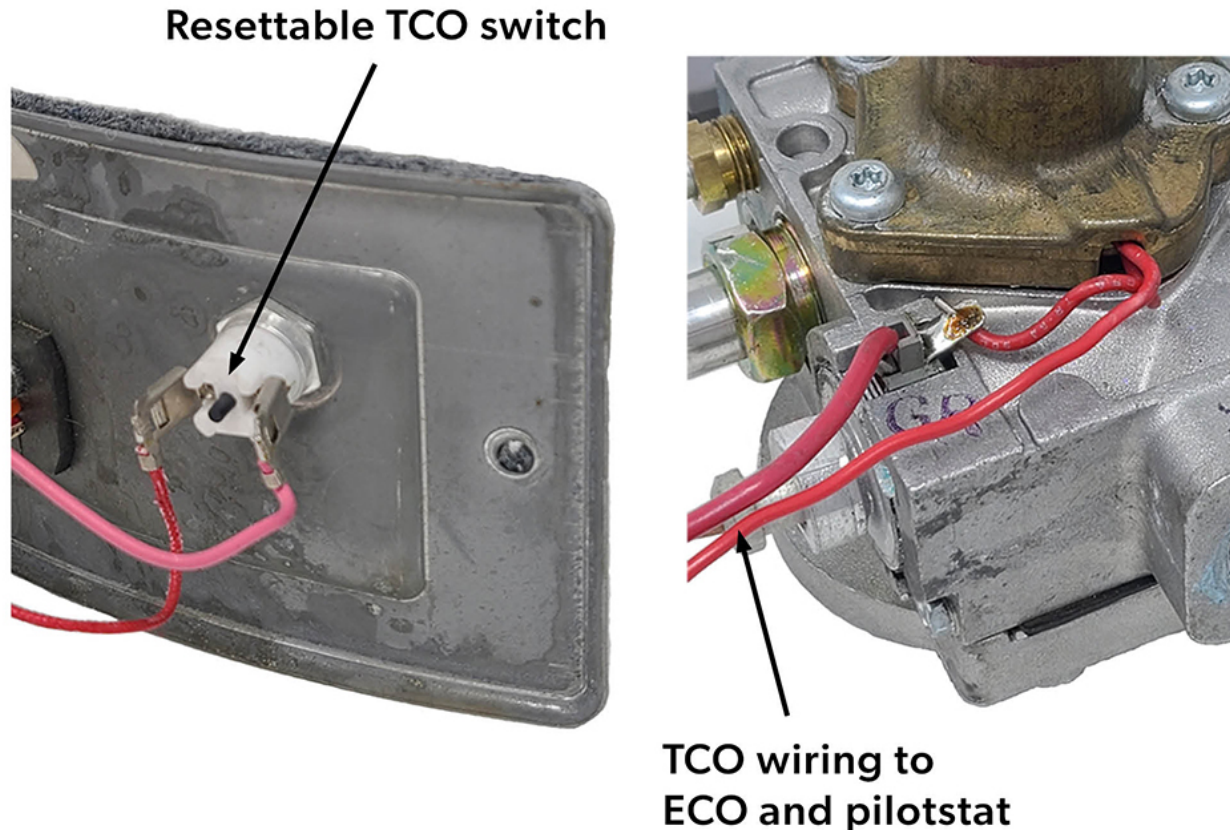

Figure 74. TCO and wiring connections

The excessive combustion chamber temperatures may be generated by a restriction to the combustion air flow, such as an accumulation of lint and dust on the flame-arrester (located underneath the combustion chamber). The TCO is also part of the manufacture's *flammable vapour ignition resistant* (FVIR) system in that the TCO will trip if there is ignition of any flammable vapours, such as gasoline, inside the combustion chamber.

### Self-Energized

A self-energized style of standing pilot water heater gas valve uses a thermopile instead of a thermocouple. The use of a 750 mV thermopile enables the pilot flame to generate enough electrical energy to power a circuit board inside the gas valve (Figure 75). The combustion chamber TCO is still wired in series with the two wires from the thermopile, (red and white), which are plugged into the front of the gas control valve where they connect to the circuit board (micro controller).

The micro-controller compiles the status of heater operation, issues error codes via an LED status light, and controls the operation of main burner. Instead of a rod and tube the water temperature is sensed by two matching *negative temperature coefficient* (NTC) thermistor sensors located in the immersion well. Thermistors are heat sensitive variable resistors, so a change in water temperature changes the resistance of the thermistors. The gas control circuit board interprets the thermistor resistance to accurately conclude the water temperature and turn the burner on or off. Having two thermistors

provides a safety backup; if the micro controller reads a different temperature between the thermistors the system goes into error mode. The COM terminals are a communication connection that enable the water heater manufacturer to connect additional accessories, such as a timer or Wi-Fi controller.

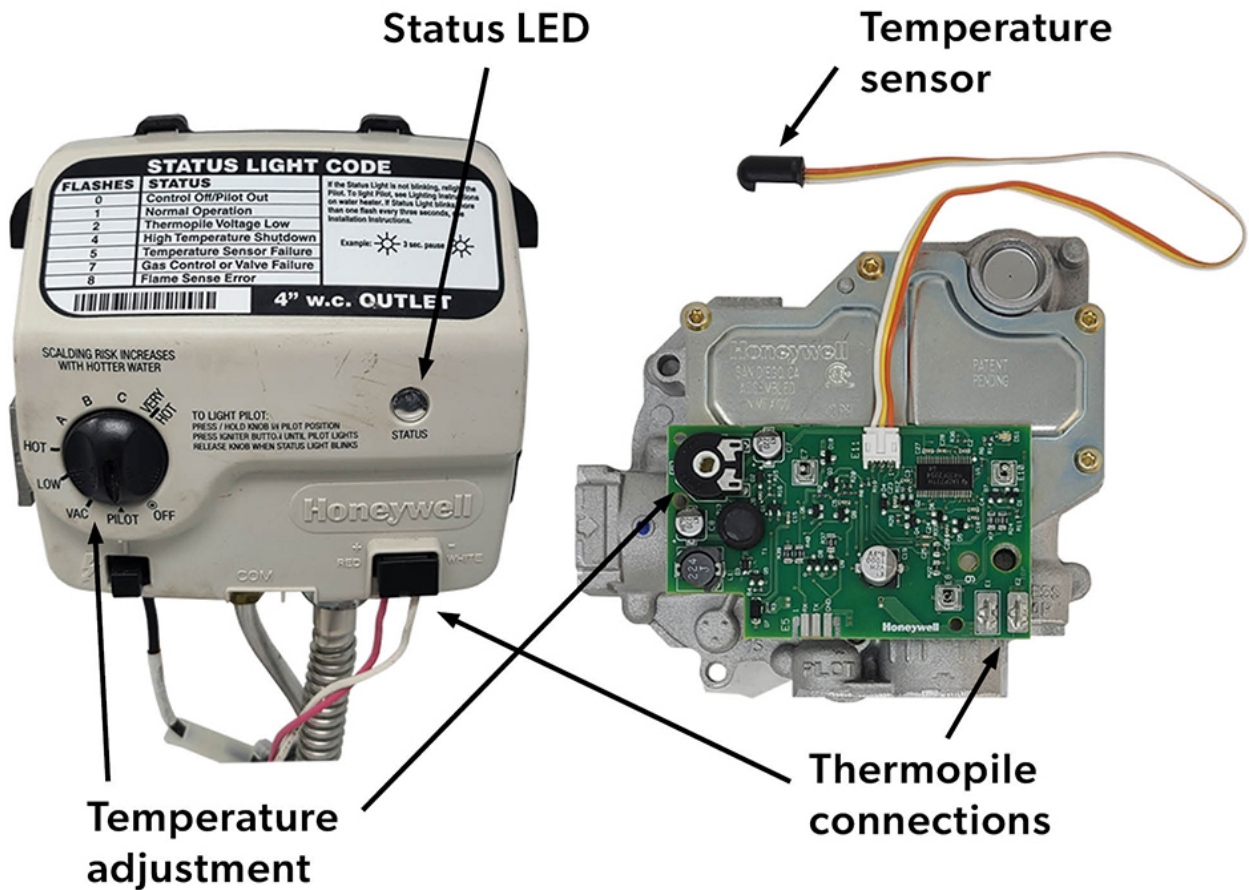

Figure 75. Self energized water heater gas valve

The gas valve is made up of five major components (Figure 76); designed so that any one of them may be replaced without replacing the entire control valve, or draining the tank, as the plastic backplate and immersion well can remain installed.

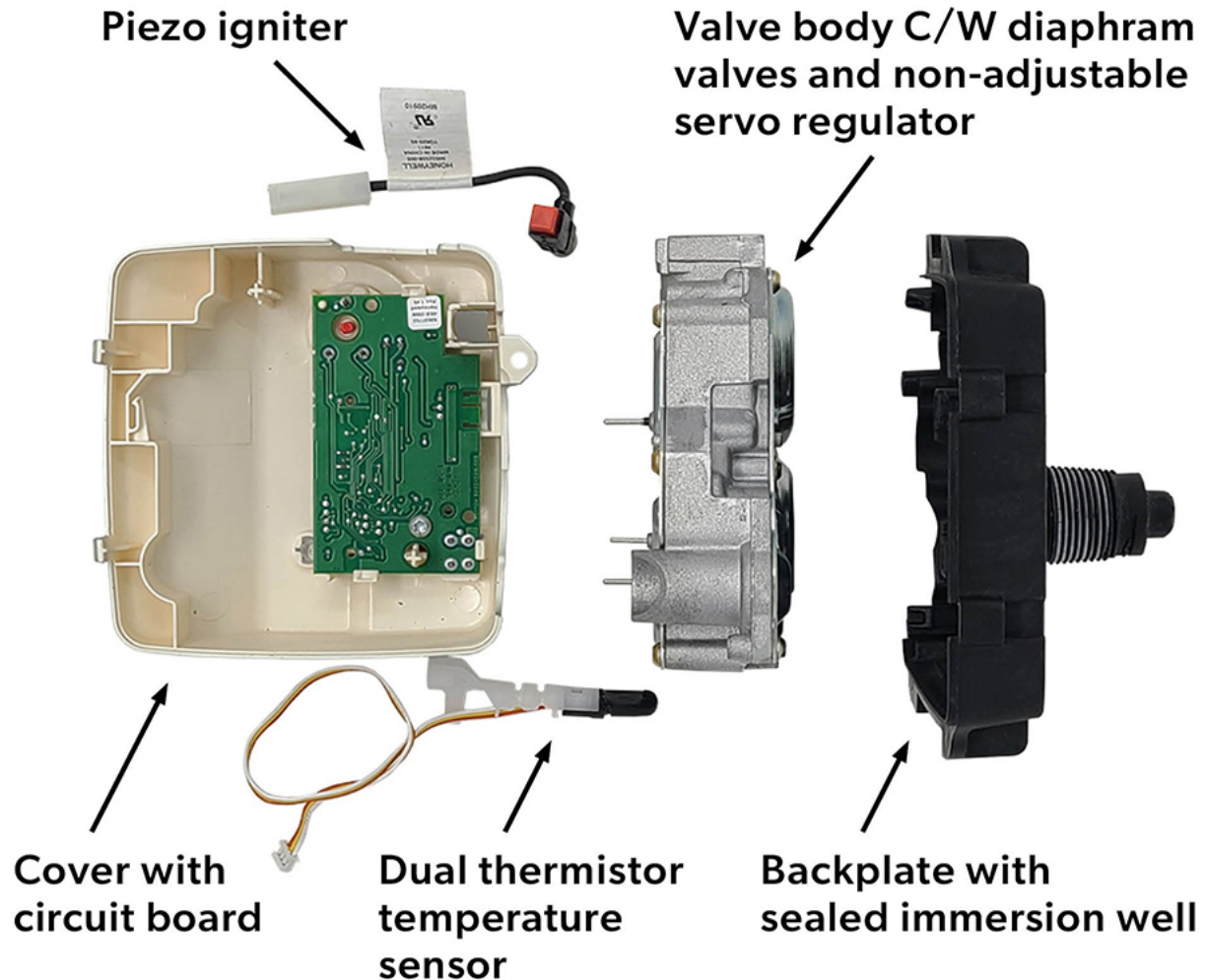

Figure 76. Separated major components

### Intermittent pilot types (electric)

Storage water heaters with higher efficiency ratings will have electronic ignition instead of a continuous pilot. They may also have power vent blowers, dampers, and condensing heat exchangers. These water heaters require a 120 VAC power supply to run the blower, and cannot produce hot water during a power outage.

Some models and brands of gas valve have an internal transformer that converts the 120 VAC into 24 VAC to power the gas valve, while other heaters use 120 VAC supply to operate the gas valve (Figure 77).



Figure 77. Two common models of electric storage water heater gas valves

These valves will also use dual NTC thermistors in the immersion well to measure the water temperature (Figure 78). In addition to the task of operating the gas valve to maintaining the water temperature, the internal micro controller will also activate, monitor and self diagnose the; vent blower, pre-purge period, vent pressure switch, electric igniter, electronic flame sensor, vent temperature switch, water temperature high limit (ECO), and flammable vapour (FV) sensor.

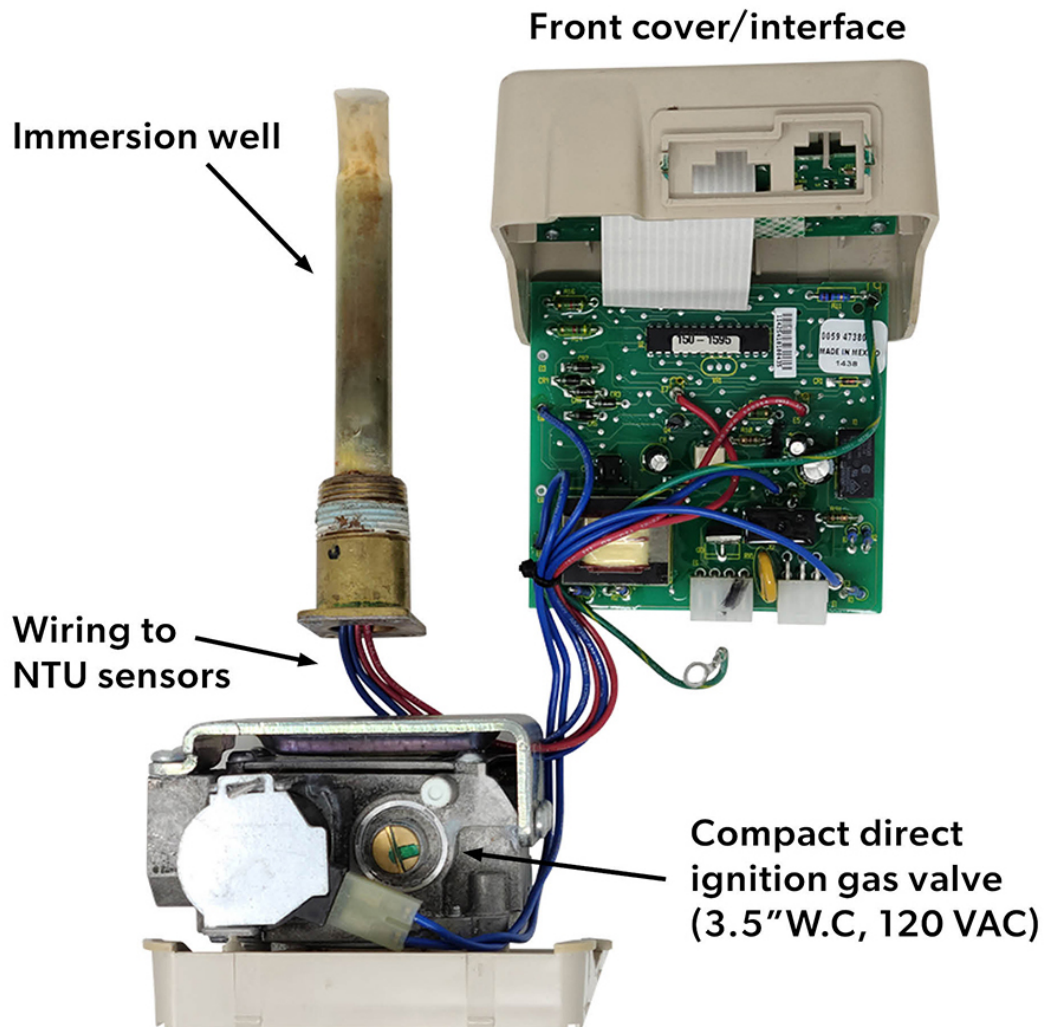

Figure 78. Disassembled electric gas valve

### Flammable Vapour Ignition Resistance

For power vented water heaters the electric gas valves used a Flammable vapor (FV) sensor as part of the FVIR system, to sense flammable vapors before they enter the combustion chamber. This is different than the standing pilot water heater, which used the TCO to react to the ignition of flammable vapours in the combustion chamber.

The FV sensor is located on the on outside lower front of the water heater within a protective plastic cover. In Figure 79 the plastic cover has been removed and the sensor separated from the base mount. Notice there are many air openings in the sensor protective housing, if the free flow of air to the sensor is blocked or has been covered with dust, leaves, water etc., it will not function.

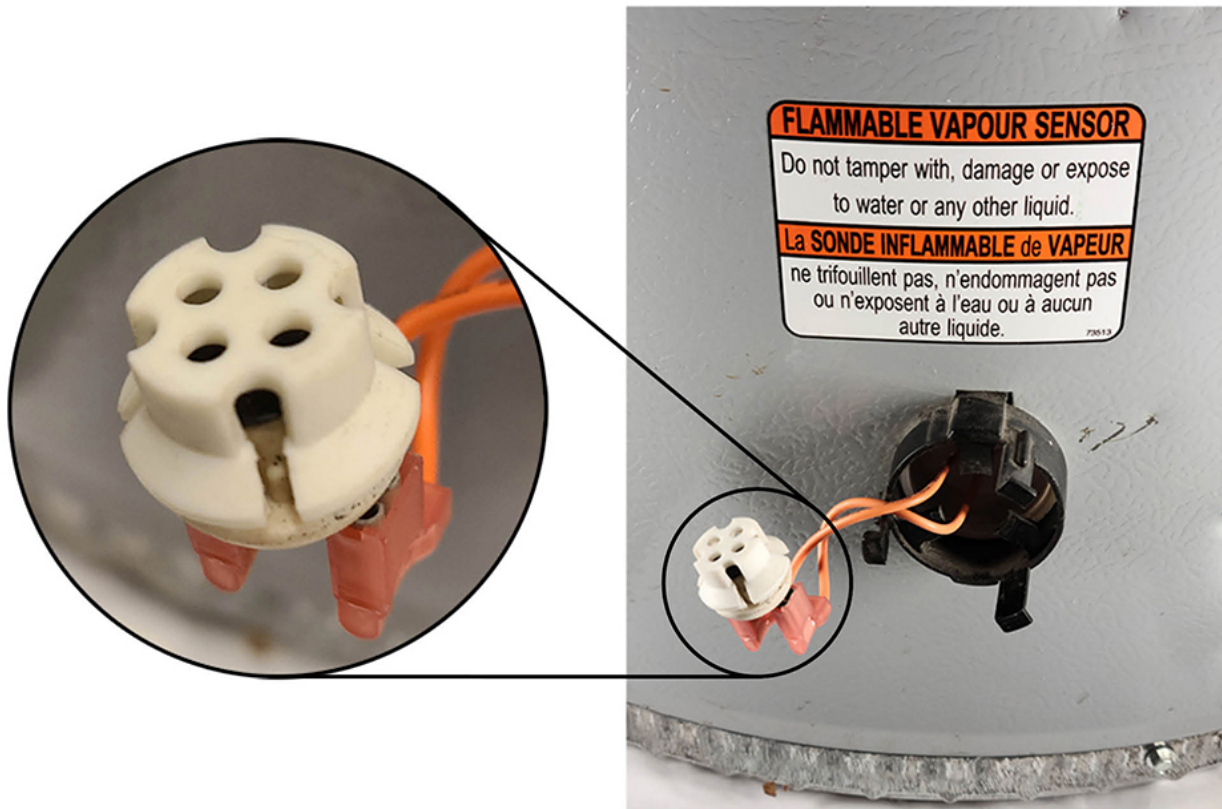

Figure 79. FV sensor

If the FV sensor detects the presence of flammable vapours while the water heater is operating, the gas control will switch to lock-out mode and the water heater will shut down. If the water heater is not operating when the flammable vapours are detected, the control will switch to lock-out mode and prevent the water heater from lighting.

After a flammable vapour incident has occurred and the flammable vapours have dissipated, the FV sensor is designed to automatically reset itself. However, the gas valve controllers may go into lock-out mode and will need to be manually reset. In most instances, there will not have been ignition of flammable vapours inside the combustion chamber because the FV sensor will have detected these vapours and shut down the water heater.

The sensor must have continuity, so a small current of electricity can pass through the sensor that signals to gas control valve that no gasoline vapor is detected. The FV sensor is easily tested using multimeter and can be replaced by plugging new one into the terminals

On standing pilot water heaters, the TCO also protected the unit from restricted combustion air flow. Whereas on these electric units instead of the TCO a high vent temperature switch (HLS) is used, as shown in Figure 80 as a component on the blower unit.

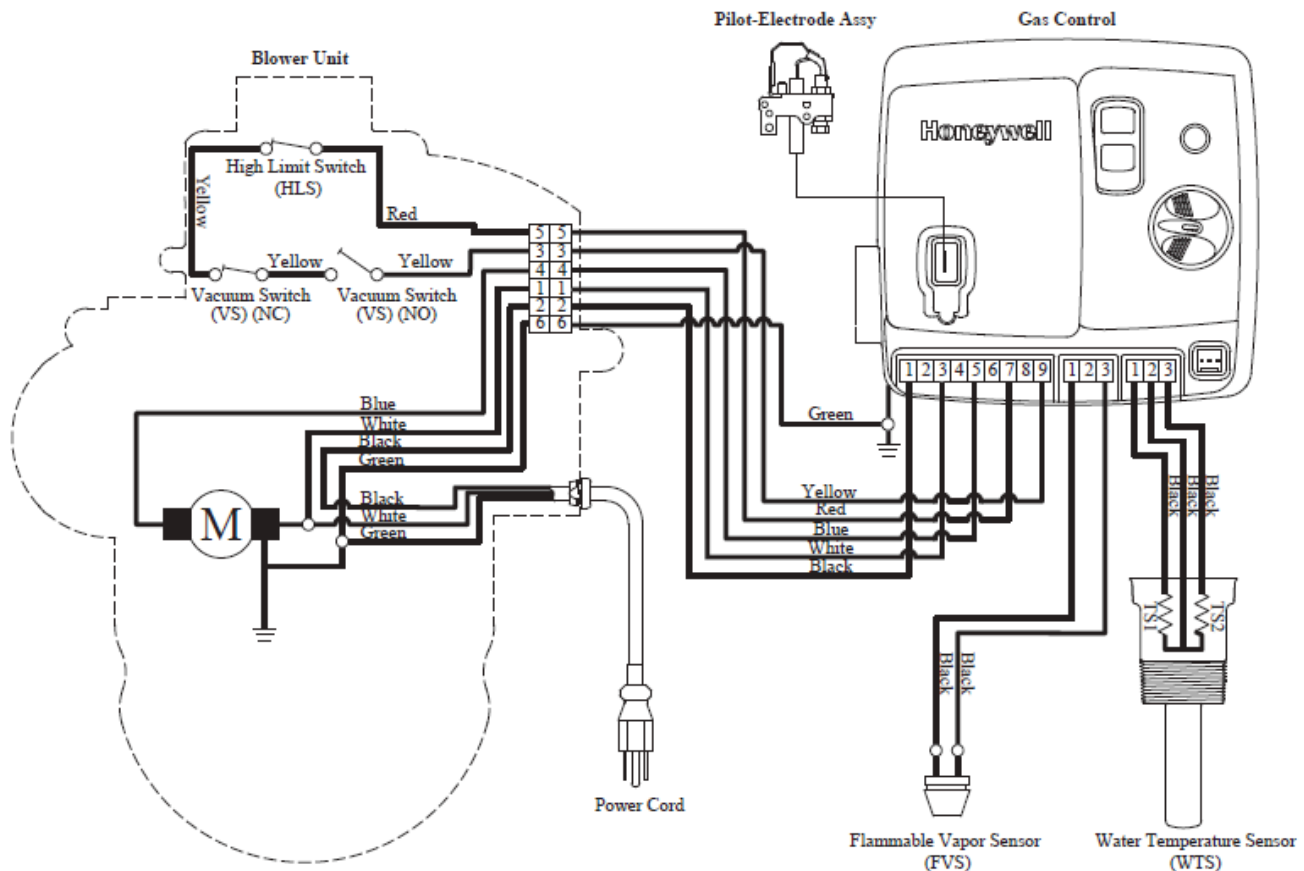

Figure 80. Honeywell connection diagram

## Non electric gas valves

Besides the Rod and tube gas valve there are a number of other non -electric gas valves. Some are used for temperature control others are used as specialty safety valves.

### Hydraulically operated

Hydraulically operated gas valves are a type of non-electric gas control valve used for temperature control on cooking, fireplaces, and free standing space heating equipment. These appliances will have a pilot burner and the hydraulic actuator will only control the flow to the main burner. Hydraulic actuators are also referred to as hydraulic thermostats or a capillary tube device as the operator is made up of a sensing bulb filled with a liquid that has a high coefficient of expansion.

When a temperature change is sensed by the bulb it causes a change in the volume of the liquid. The liquid volume change is transferred through a capillary tube to a sealed bellows causing it to expand or contract. The sealed bellows is usually acting upon a snap acting disc, similar to the rod and rod sensor, which requires a minimum amount of temperature change before snapping open or shut. Figure 81 shows a valve with the temperature below the setpoint and the valve in the open position.

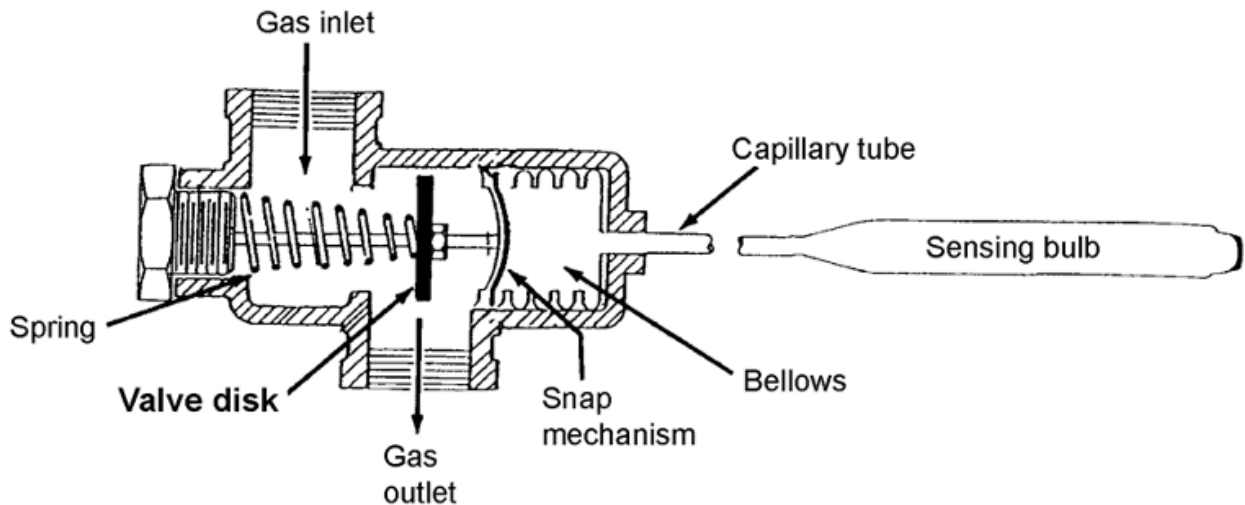

Figure 81. Capillary tube valve components

Figure 82 shows a common diaphragm operated control valve which can be supplied with different types of actuators, one of which is the hydraulic type which does not require a power source.

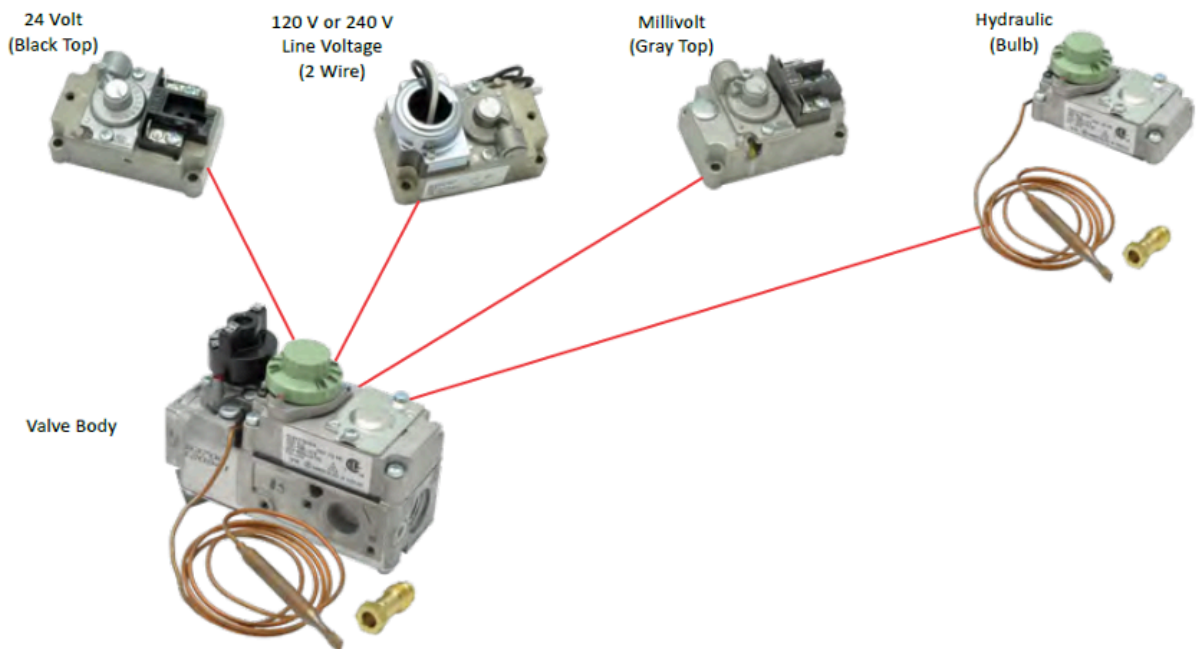

Figure 82. Actuator options

Besides snap-action where the valve is fully open or closed most valve manufactures also have modulating (snap-throttle, modusnap) types. Modulating hydraulic thermostat is similar to the snap-action, except that the valve initially snaps on and shuts off at a pre-set minimum input. If the temperature continues to drop the input will alter between full and minimum. Figure 83 shows the valve with the pilot safety valve being held open by the thermocouple. The temperature setpoint is satisfied so the double seated valve is closed.

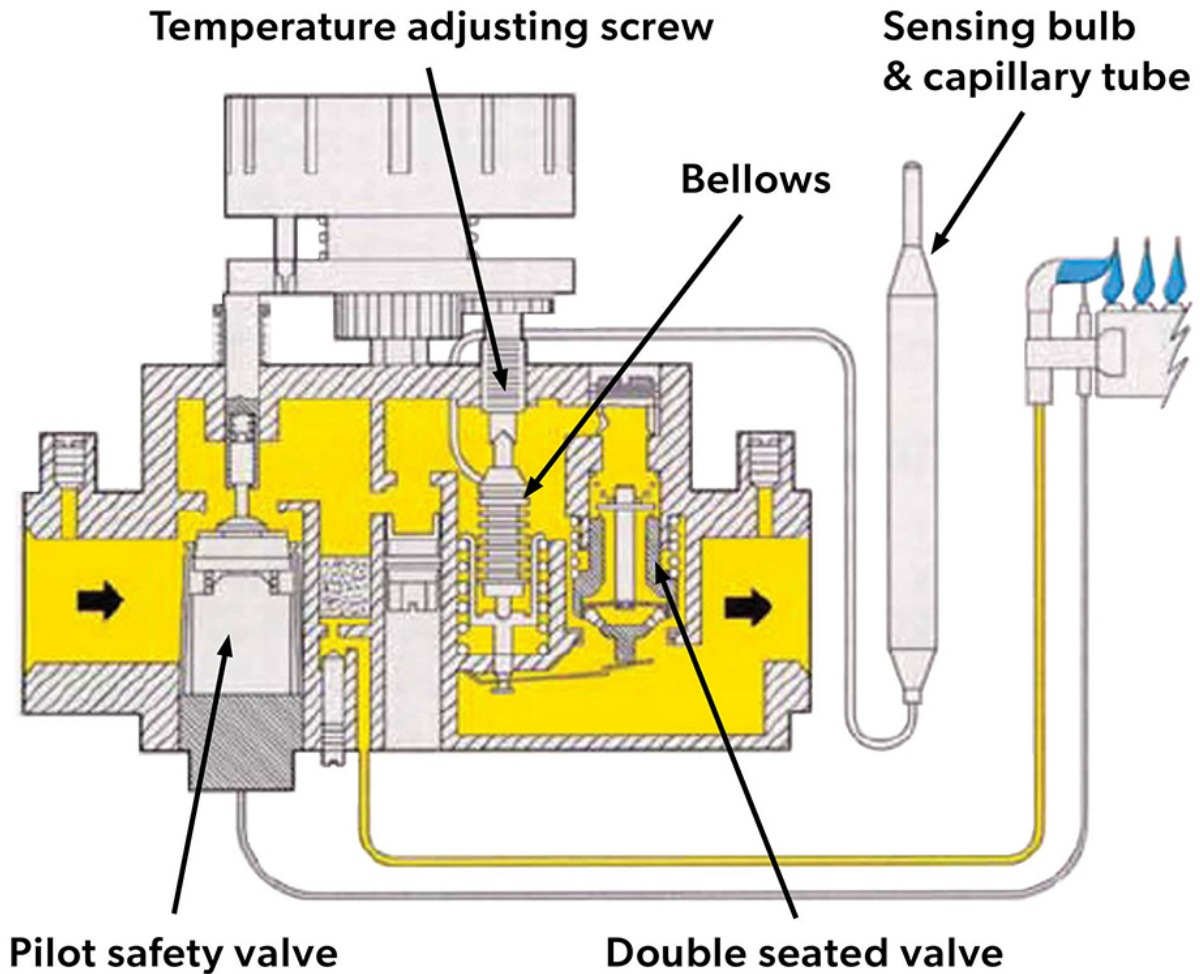

Figure 83. Modulating hydraulic valve closed position

You can see in Figure 84 (left) the temperature has dropped below the temperature setpoint and the inner snap acting valve seat is in the open position. This inner seat supplies the minimum rate of gas flow, if the heating requirement is satisfied the temperature will rise and the valve will snap shut.

If more heat is required (right), the bellows continues to contract and the outer throttling valve seat is lifted to adjust the gas flow rate between the fixed minimum and full burner capacity.

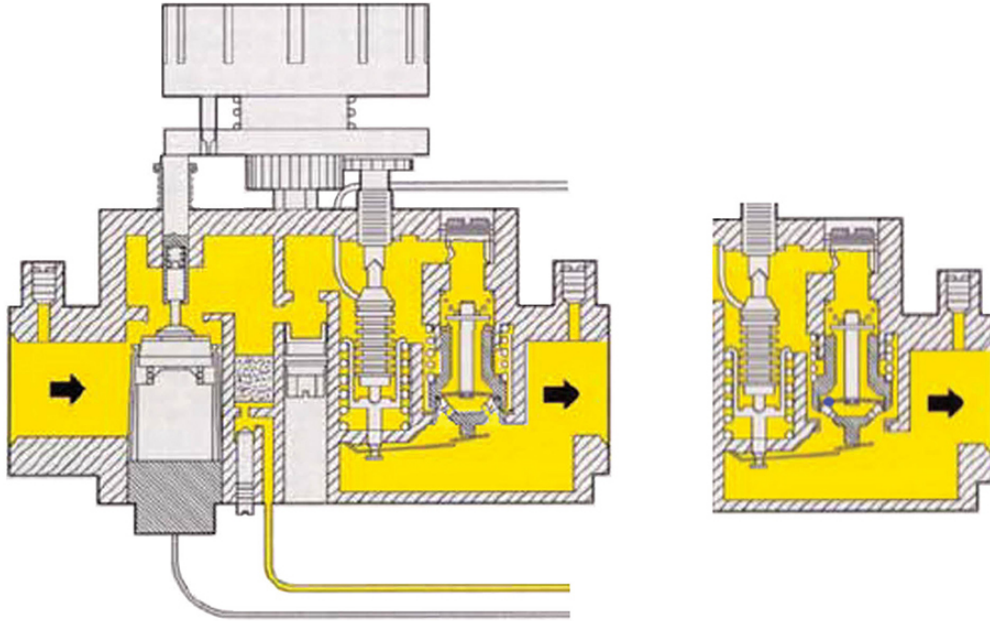

Figure 84. Hydraulic Modulating valve, left low fire, right throttling

The gas flow and temperature settings have been plotted in Figure 85 to better understand the operating sequence:

- The red line on the temperature represents the temperature dropping below the setpoint. When it reaches the pre-set differential (a) below the setpoint the valve snaps open to the low fire rate.
- If the sensed temperature rises back up to the setpoint, the snap valve will close
- If the temperature continues to drop while at low fire, and gets to the pre-set differential (b) then the modulating seat begins to open increasing the flow proportionately (c) until the valve is fully open at high fire.

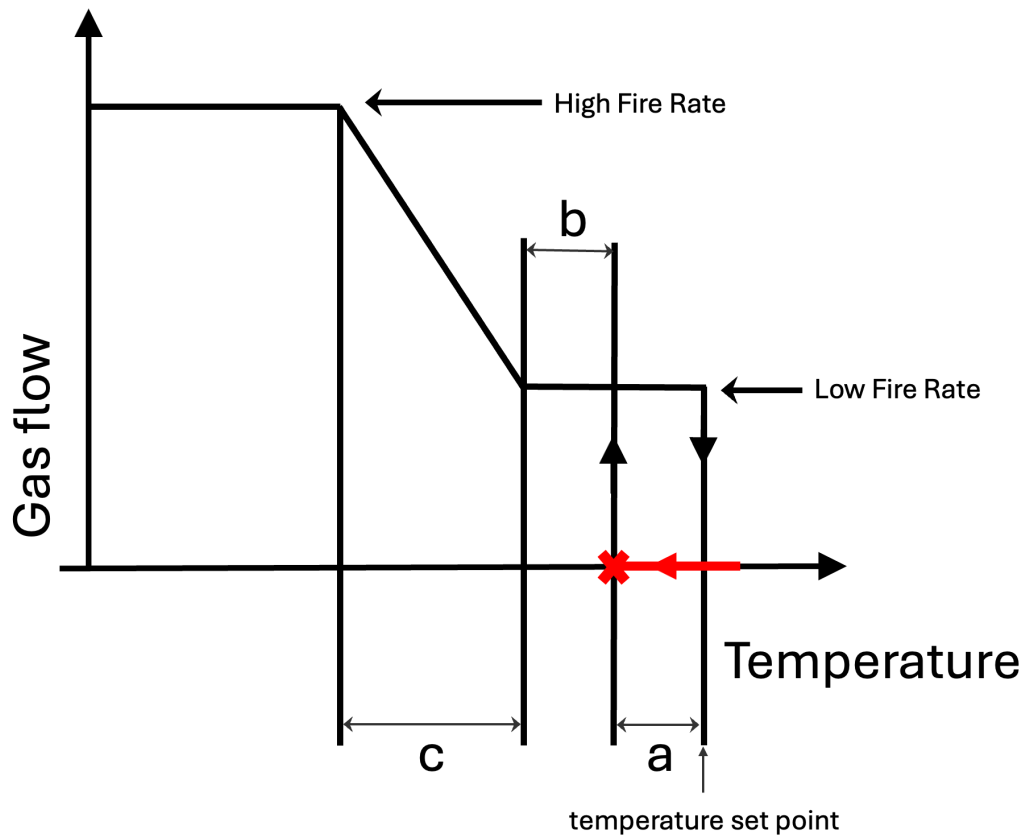

Figure 85. Snap/modulating gas flow

### Hydraulic switches

Capillary temperature sensors are also used to operate electric switch's on gas valve electric circuits. Figure 86 is an example of a hydraulically operated pilot safety switch. At first glance the sensing bulb and capillary tube look very similar to a thermocouple system. Upon closer inspection of the blow-up image of the gas valve you can see that the capillary tube is connected to a bellows. This is a 24 VAC standing pilot gas valve and the bellows holds in a pilot safety switch as long as the pilot is lit.

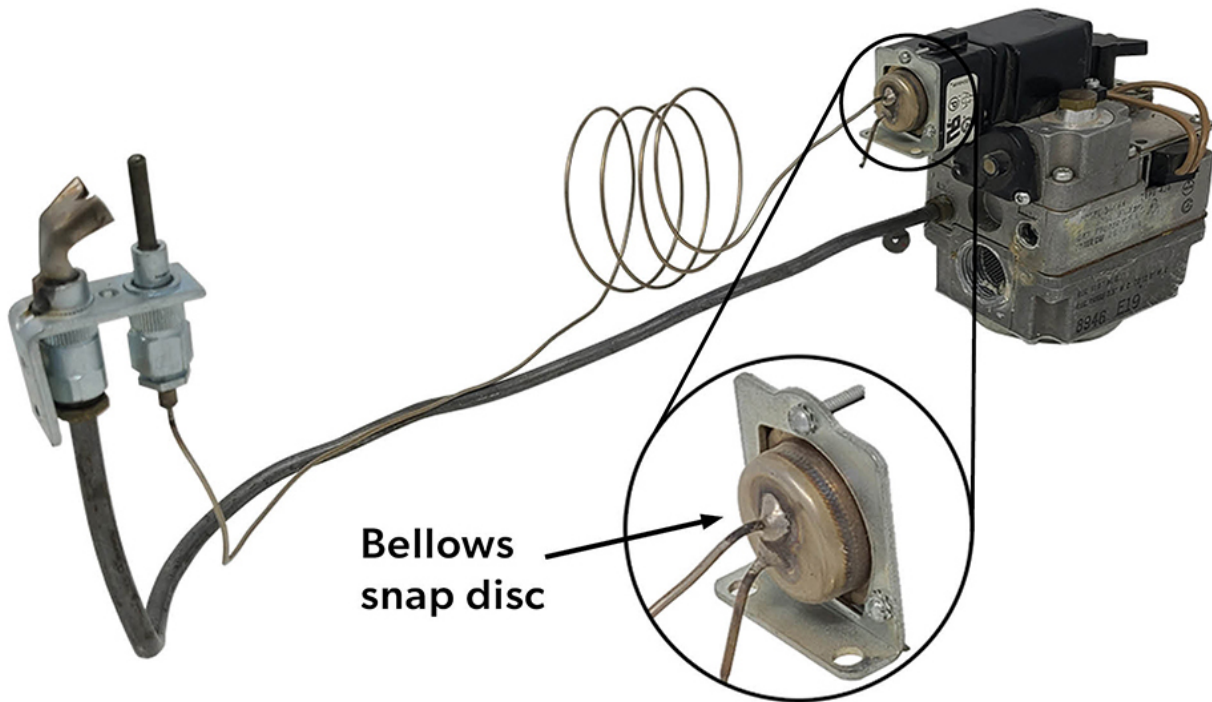

Figure 86. Capillary pilot safety

This is just one example, but capillary tube operated electric switches are also used as high limits and temperature control on millivolt and VAC operated gas valves.

### Oven gas valves

Range oven gas valves are a hybrid of both electric and non electric operating components (Figure 87). The wiring of diagram of the 120VAC gas valve control circuit shows that the thermostat energizes both the hot surface Ignitor and the thermal bi-metal gas valve. The thermostat is a hydraulic bellows snap switch with a capillary tube leading to the sensing bulb located within the oven. Because the thermostat, HSI and gas valve are wired in series, meaning electricity must pass through the glow bar and then to the valve. The HSI blocks current to the gas valve through electrical resistance that declines as the igniter's temperature rises. When the igniter reaches yellow heat, sufficient to ignite the gas, it allows passage of enough electricity to open the gas valve.

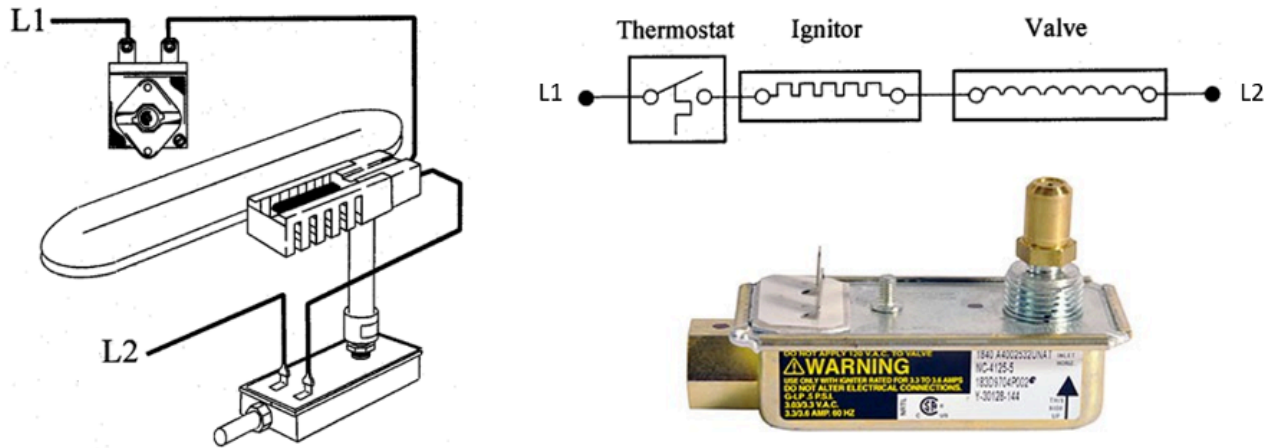

Figure 87. Range oven and broiler gas valve

Inside the gas valve there is a bi-metal strip that lifts the valve disc from its seat when the bimetal is adequately heated by the insulated heating element wrapped around its base (Figure 88).

This simple circuit has a built-in safety in that, if the igniter is damaged the current will not get to the gas valve.

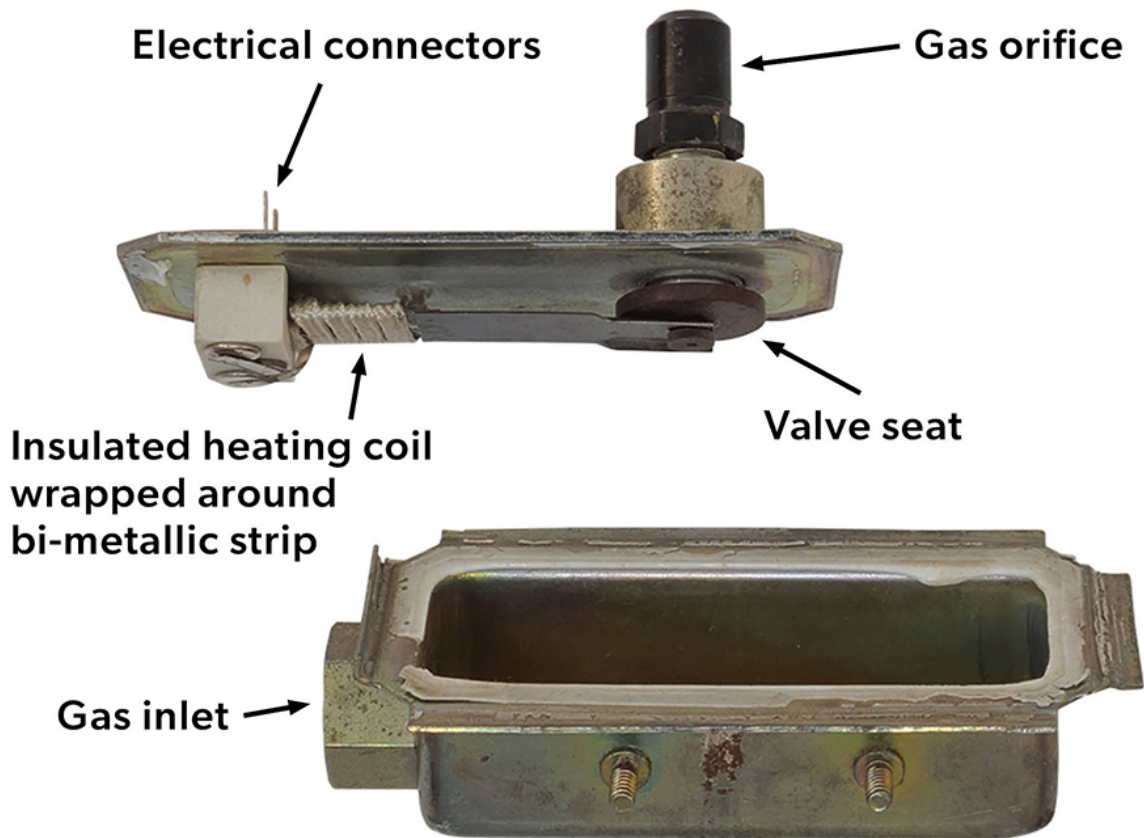

Figure 88. Oven gas valve internal components

## Seismic gas valve

Seismic gas valves are a safety valve designed to shut off gas supply to a building during an earthquake. Figure 89 shows two popular models, both need to be installed level as they have an internal ball which moves when subject to horizontal vibration. They have an indicating window and must be manually reset once activated. When installing make sure to check the direction of flow.



Figure 89. Earthquake valves

## Fire suppression gas valves

Commercial kitchen equipment with exhaust systems will have an automatic fire extinguishing system. The gas code requires, that any gas appliances protect or affected by the fire extinguishing system must be interlocked so the gas supply is shut off when the system is activated.

The gas shutoff valve must be resettable and located outside the protected area. The automatic fast closing valve may be either electrically or mechanically operated. Electrical types will be a typically solenoid valve, whereas the non-electric mechanical types will have cable activation system.

The cable system shown in Figure 90 has a spring loaded, release-to-close gas valve (bottom left) which is being held open by the cable which can be released by a manual pull station (bottom right) or a temperature activated fusible link located above the cooking equipment (top photo), either of which also releases the extinguishing agent onto the area.



Figure 90. Kitchen exhaust fire extinguishing system



Now complete Self-Test 4 and check your answers.

## Self-Test 4

### Self-Test 4



An interactive H5P element has been excluded from this version of the text. You can view it online here: <https://opentextbc.ca/plumbing4b/?p=36#h5p-4>

## Media Attributions

- Figure 41. “Solenoid valve” – The source for this image is unknown. It is being used for non-commercial, educational purposes. To receive credit for this image, please reach out to the publisher.
- Figure 42. “Pilot burner solenoid valve” by Rod Lidstone is licensed under a [CC BY-NC-SA licence](#).
- Figure 43. “Automatic safety shut-off valve operation” – The source for this image is unknown. It is being used for non-commercial, educational purposes. To receive credit for this image, please reach out to the publisher.
- Figure 44. “Water heater combination gas valve” by Rod Lidstone is licensed under a [CC BY-NC-SA licence](#).
- Figure 45. “1 ½” Diaphragm gas valve” by Rod Lidstone is licensed under a [CC BY-NC-SA licence](#).
- Figure 46. “Diaphragm gas valve operation” – The source for this image is unknown. It is being used for non-commercial, educational purposes. To receive credit for this image, please reach out to the publisher.
- Figure 47. “[Internal bleed diaphragm gas valve](#)” from Robertshaw Controls Co. is used and adapted for educational purposes under the basis of fair dealing.
- Figure 48. “Millivolt combination gas valve” by Rod Lidstone is licensed under a [CC BY-NC-SA licence](#).
- Figure 49. “1” Combination regulating diaphragm gas valve” by Rod Lidstone is licensed under a [CC BY-NC-SA licence](#).
- Figure 50. “Servo diaphragm valve closed” – The source for this image is unknown. It is being used for non-commercial, educational purposes. To receive credit for this image, please reach out to the publisher.

- Figure 51. “Servo diaphragm valve wide open” – The source for this image is unknown. It is being used for non-commercial, educational purposes. To receive credit for this image, please reach out to the publisher.
- Figure 52. “Servo diaphragm valve throttling” – The source for this image is unknown. It is being used for non-commercial, educational purposes. To receive credit for this image, please reach out to the publisher.
- Figure 53. “Combination servo gas valve” from Honeywell International Inc. is used for educational purposes under the basis of fair dealing.
- Figure 54. “[Redundant gas valve internal flow](#)” from White-Rodgers and Emerson is used for educational purposes under the basis of fair dealing.
- Figure 55. “[Universal combination redundant gas valves](#)” from White-Rodgers and Emerson is used and adapted for educational purposes under the basis of fair dealing.
- Figure 56. “Compact direct ignition gas valve” from White-Rodgers and Emerson is used for educational purposes under the basis of fair dealing.
- Figure 57. “[Double seated redundant gas valve internal flow](#)” from White-Rodgers and Emerson is used for educational purposes under the basis of fair dealing.
- Figure 58. “Sealed combustion chamber pressures”.
  - “[Furnace Vent](#)” (Left) – The source for this image is unknown. It is being used for non-commercial, educational purposes. To receive credit for this image, please reach out to the publisher.
  - (Right) – The source for this image is unknown. It is being used for non-commercial, educational purposes. To receive credit for this image, please reach out to the publisher.
- Figure 59. “Combustion chamber reference tube”.
  - (Left) – The source for this image is unknown. It is being used for non-commercial, educational purposes. To receive credit for this image, please reach out to the publisher.
  - (Right) by Rod Lidstone is licensed under a [CC BY-NC-SA licence](#).
- Figure 60. “[Two stage redundant gas valve](#)” from White-Rodgers and Emerson is used and adapted for educational purposes under the basis of fair dealing.
- Figure 61. “Modulating venturi burner”.
  - “[GB-WND 055 Functional Diagram](#)” (Left) from DUNGS Combustion Controls is used and adapted for educational purposes under the basis of fair dealing
  - (Right) – by Rod Lidstone is licensed under a [CC BY-NC-SA licence](#).
- Figure 62. “Air supply connection” by Rod Lidstone is licensed under a [CC BY-NC-SA licence](#).
- Figure 63. “Zero governor reference tube” by Rod Lidstone is licensed under a [CC BY-NC-SA licence](#).
- Figure 64. “Modulating solenoid servo regulator” – The source for this image is unknown. It

is being used for non-commercial, educational purposes. To receive credit for this image, please reach out to the publisher.

- Figure 65. “Stepper Combination Gas Valve” from White-Rodgers and Emerson is used for educational purposes under the basis of fair dealing.
- Figure 66. “Millivolt combination gas valve” by Rod Lidstone is licensed under a [CC BY-NC-SA licence](#).
- Figure 67. “Millivolt pilot burner” by Rod Lidstone is licensed under a [CC BY-NC-SA licence](#).
- Figure 68. “Millivolt gas valve wiring connections” – The source for this image is unknown. It is being used for non-commercial, educational purposes. To receive credit for this image, please reach out to the publisher.
- Figure 69. “[Battery operated fireplace controls system](#)” from SIT is used for educational purposes under the basis of fair dealing.
- Figure 70. “Standing pilot non-electric storage water heater gas valve components” by Rod Lidstone is licensed under a [CC BY-NC-SA licence](#).
- Figure 71. “Rod and tube temperature sensor” by Rod Lidstone is licensed under a [CC BY-NC-SA licence](#).
- Figure 72. “Rod and Tube operation” – The source for this image is unknown. It is being used for non-commercial, educational purposes. To receive credit for this image, please reach out to the publisher.
- Figure 73. “ECO cutaway” by Rod Lidstone is licensed under a [CC BY-NC-SA licence](#).
- Figure 74. “TCO and wiring connections” by Rod Lidstone is licensed under a [CC BY-NC-SA licence](#).
- Figure 75. “Self energized water heater gas valve” by Rod Lidstone is licensed under a [CC BY-NC-SA licence](#).
- Figure 76. “Separated major components” by Rod Lidstone is licensed under a [CC BY-NC-SA licence](#).
- Figure 77. “Two common models of electric storage water heater gas valves” by Rod Lidstone is licensed under a [CC BY-NC-SA licence](#).
- Figure 78. “Disassembled electric gas valve” by Rod Lidstone is licensed under a [CC BY-NC-SA licence](#).
- Figure 79. “FV sensor” by Rod Lidstone is licensed under a [CC BY-NC-SA licence](#).
- Figure 80. “[Honeywell connection diagram](#)” from Honeywell International Inc. is used for educational purposes under the basis of fair dealing.
- Figure 81. “Capillary tube valve components” – The source for this image is unknown. It is being used for non-commercial, educational purposes. To receive credit for this image, please reach out to the publisher.
- Figure 82. “[Actuator options](#)” from Robershaw is used for educational purposes under the basis of fair dealing.

- Figure 83. “[Modulating hydraulic valve closed position](#)” from SIT is used for educational purposes under the basis of fair dealing.
- Figure 84. “[Hydraulic Modulating valve, left low fire, right throttling](#)” from SIT is used for educational purposes under the basis of fair dealing.
- Figure 85. “Snap/modulating gas flow” by BCcampus is licensed under a [CC BY-NC-SA licence](#).
- Figure 86. “Capillary pilot safety” by Rod Lidstone is licensed under a [CC BY-NC-SA licence](#).
- Figure 87. “Range oven and broiler gas valve”.
  - “[Robertshaw Y-75001-AF12](#)” (Bottom right) from Robertshaw is used for educational purposes under the basis of fair dealing.
  - (Left) and (top right) by Rod Lidstone is licensed under a [CC BY-NC-SA licence](#).
- Figure 88. “Oven gas valve internal components” by Rod Lidstone is licensed under a [CC BY-NC-SA licence](#).
- Figure 89. “[Earthquake valves](#)” from Seismic Safety Products is used for educational purposes under the basis of fair dealing.
- Figure 90. “Kitchen exhaust fire extinguishing system” by Rod Lidstone is licensed under a [CC BY-NC-SA licence](#).

## Image Description

**Figure 53. “Combination servo gas valve” image description:** A labeled diagram of a combination servo gas valve, with its main components identified in a clockwise direction starting from the top:

- Control knob (pilot on/off)
- Servo pressure regulator
- Bleed vent
- Servo regulator diaphragm
- Servo regulator valve
- Servo regulator pressure chamber
- Valve operator on/off lever (solenoid operated)
- Evacuation channel
- Pilot gas
- Gas outlet
- Working gas chamber

Continuing clockwise along the bottom of the regulator:

- Working gas pressure chamber
- Main valve diaphragm
- Main valve
- Safety valve

Finally, moving up the left side of the diagram:

- Gas inlet
- Power unit (safety shut-off) [\[Return Figure 53\]](#)

**Figure 57. “Double seated redundant gas valve internal flow” image description:** A numbered diagram with a corresponding list as follows:

1. Valve solenoid
2. Pressure tap inlet
3. Redundant valve
4. Main valve
5. Supply inlet
6. Diaphragm
7. Regulator valve
8. Main burner outlet
9. Servo regulator
10. Regulator adjust screw
11. Pressure tap outlet
12. Working gas orifices [\[Return to Figure 57\]](#)

# Competency B2: Install Regulators, Valves, and Valve Train Components

You need to be aware of the code installation regulations pertinent to the location and applications on which you are working. The valves and regulators that are used must comply with the applicable standards and must be installed as per the manufacturer's installation instructions.

## Learning Objectives

After completing the learning tasks in this competency, you will be able to:

- Describe the installation requirements for manual gas shut-off valves
- Describe the installation requirements for pressure regulators



## Learning Task 1

### Installing Manual Valves

Proper location of manual shut-off valves is critical to ensure a gas piping system can be shutoff for both emergencies and equipment maintenance. The gas code specifies particular locations that require the installations of manual shut-off valves.

To ensure that valves are working properly, they must suit the application and be correctly installed.

### Code requirements

Most gas shut-off applications will require the use of a manual valve that will fully open or close with a quarter-turn of the handle. The gas codes identify specific locations and equipment that require the installation of manual shut-off valves. Here are some examples that are identified in the B149.1 gas installation code:

- Automatic fire extinguishing systems
- Pressure regulators
- Test ports
- Quick-disconnect devices
- Supply to underground plastic pipe
- Appliance shut-offs
- Multiple piping systems
- Multiple buildings served
- Multiple propane risers from underground main
- Classroom or lab master shut-offs
- Gas hoses
- Purging operations
- Emergency generators
- Construction heaters

Check the code index listings under “manual shut-off” to find the installation details of each requirement.

## Manufacturers specifications

Not all valves are approved to be used in combustible gas applications. The W.O.G. pressure rating does not cover flammable gas such as Natural gas or Propane. Valves for gas service (Liquid Propane (LP) and or Natural Gas (NG) must be certified and bear the CSA mark along with the applicable marking for the type of gas application.

It is important to know the operating conditions when selecting a valve. Then check the valve markings to determine if the valve is appropriate for the application. Here is a brief description of each of the rating marks on the gas valves

### ½ PSI

- Signifies ½ psig rating for appliance manufactures' use
- ANSI Z21.15 (USA) CGA 9.1 CAN
  - “American National Standard/Canadian Gas Association Standard for Manually Operated Gas Valves For Appliances, Appliance Connector Valves and Hose Ends Valves”
- Temperature Range of 0°C to 51.5°C (32°F to 125°F)
- Intended to be used as part of a gas fired appliance
- Not for use in building piping systems

### 5G

- Signifies 5 psig rating for inline valves
- Standard 3.88 (USA) & CR91-002 (CAN)
  - “Manually Operated Gas Valves For Use On Piping”
- CR91-002 Temperature range between -40°C to 52°C (-40°F to 125°F)
- Standard 3.88 Temperature range between 0°C to 51.5°C (32°F to 125°F)

### BRS

- Signifies 125 psig rating for United States
- ASME B16.33 Standard
  - “Manually Operated Metallic Gas Valves For Use in Gas Piping Systems Up to 125 psig sizes ½” to 2”
- Temperature range between -20°F to 150°F

## CAN-3.16

- Signifies 125 psig rating for Canada for Outdoor Use
- CAN/CGA 3.16 Standard
  - “Lever Operated Non-Lubricated Gas Shut-Off Valves”
- Suitable for continuous use over the temperature range of  $-30^{\circ}\text{C}$  to  $65^{\circ}\text{C}$  ( $-22^{\circ}\text{F}$  to  $140^{\circ}\text{F}$ )

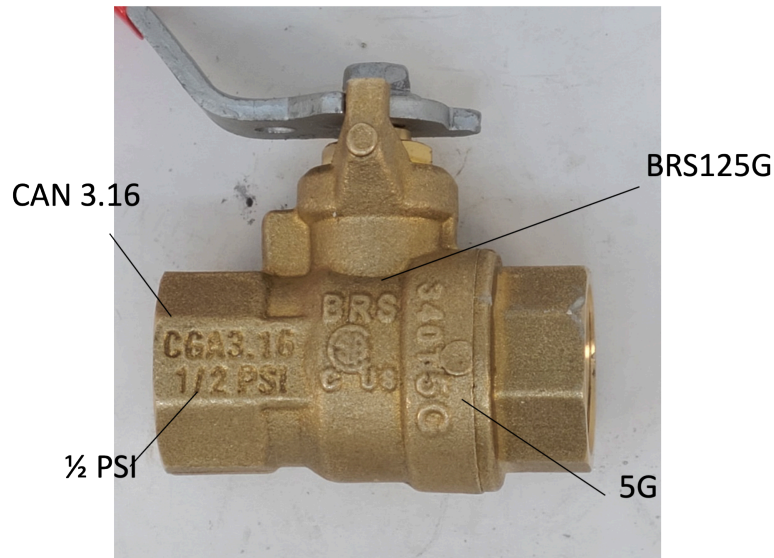

Figure 1. Valve markings

Having a 125 psi rating does not override the  $\frac{1}{2}$  PSI or 5G marks. Approval marks must be shown for the application. Valve with 5G rating are acceptable for use indoors and out in Canada. The  $\frac{1}{2}$  PSI valves are for indoor use.

## Installation procedures

To ensure that valves are working properly, it is essential that they are correctly installed.

Here are some basic valve installation guidelines:

- Review that the valve fits its intended purpose. The valve should comply with the system design, pressure, and temperature requirements
- Before installation check that the valve body, seat, and ball are free from any damage caused by transportation or storage.
- After the installation is completed, it is recommended to operate the valve multiple times to ensure it is not defective and rotates through its entire 90-degree operation.
- Ball valves can also be installed in any orientation or angle, providing there is enough space to allow for 90-degree operation. Some fitters prefer to install the valve so the handle points in the direction of flow whenever possible. Another best practice is to install the valve in the

fail-safe position (Figure 2). Fail safe means that the valve is installed so that should the packing become loose or the valve arm be unintentionally moved, the arm will move to the close position. Installation upside down is not recommended because it can cause dirt to accumulate by the stem packing.

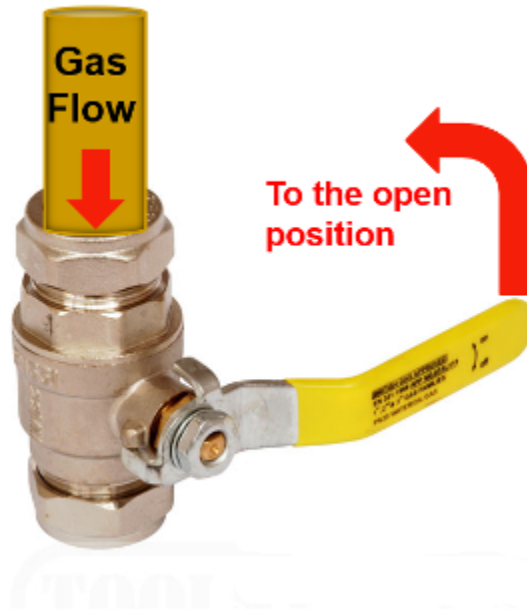

Figure 2. Ball valve fail safe position

- When installing two-piece body ball valves always use two wrenches when making up pipe joints to these valves. Position one wrench on the valve end closest to the pipe joint being tightened and the other wrench onto the pipe to prevent transmitting torque through the valve body joints. This also prevents distortion of the internal parts of the valve.

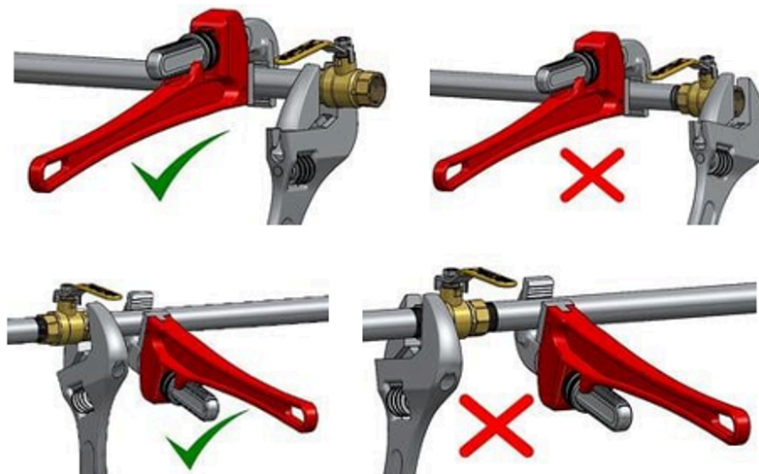

Figure 3. Wrenching ball valves

## Maintenance

Other than cycling of the valve from open to closed position periodically, inspection and maintenance are not required on manual ball valves. Repair or replacement of two-piece ball valves' internal parts is not recommended. Damage can occur to the body and tailpiece during disassembly that would make the valve inoperable.

Normal stem packing wear may cause a slow leak. If a minor leak is identified at the valve stem remove the handle and tighten the packing nut in  $\frac{1}{8}$  increments until a soap test verifies the leakage has stopped (Figure 4). Over tightening will increase the torque required to operate the valve and result in excessive wear on the packing.



Figure 4. Tightening ball valve packing nut

Lubricated plug valves usually only require relubrication once every few years unless they are exposed to a lot of heat or intense sunlight which liquifies the grease. If a faint gas odor is noticed at the gas valve it may need relubrication.

There are two common methods used to inject the approved lubricating sealant. One method is to use a high-pressure grease gun equipped with a button head coupler (figure 5). The button head grease fittings are a heavy-duty fitting distinguished by their flat low-profile appearance. By pulling onto the button head fitting, the couple slides over it to give a high pressure no leak engagement.

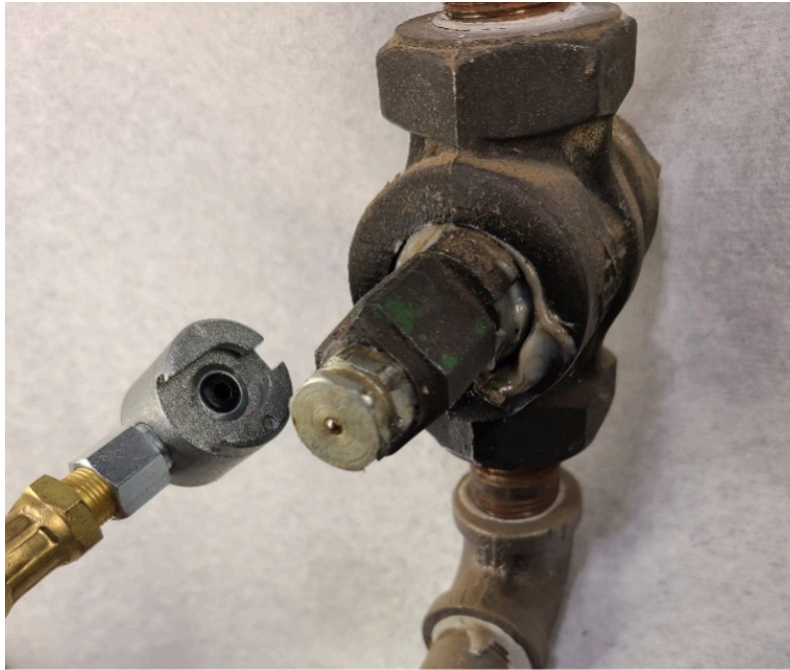

*Figure 5. Button head grease fitting and coupler*

Another method of relubrication is to use screw injector tool. A small stick of lubricant is loaded into the tool (Figure 6). When the screw is wound in it exerts a powerful hydraulic force and injects the sealant into the valve.

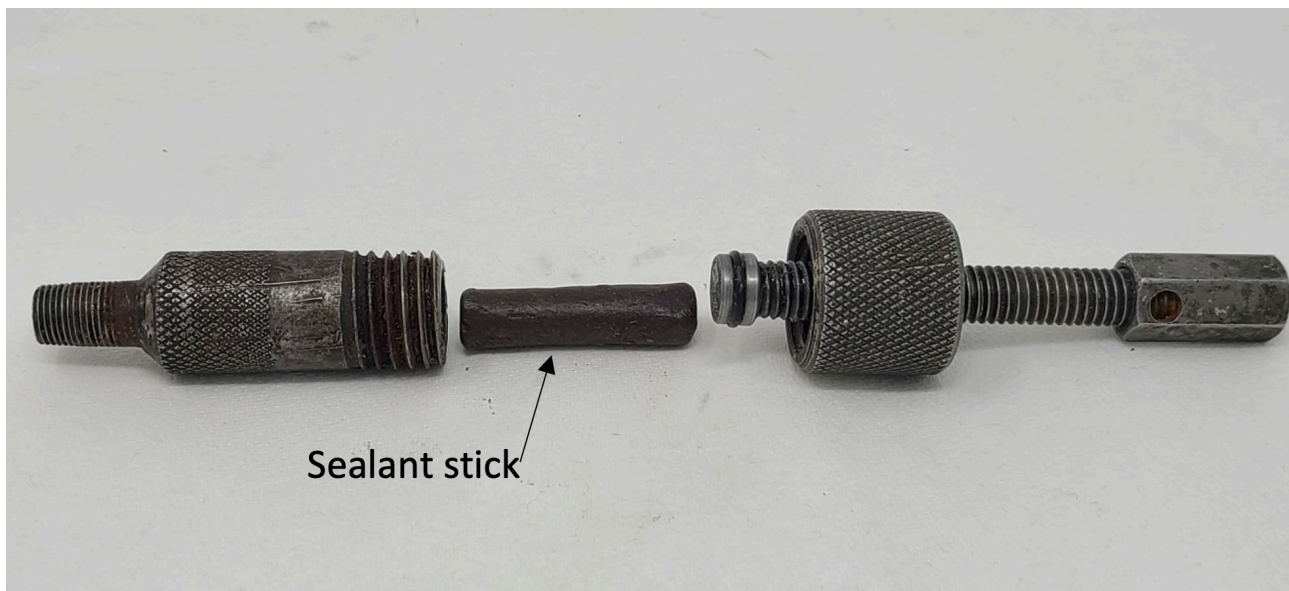

*Figure 6. Loading lubrication stick into screw injection tool*

The screw injection tool shown in Figure 7 has had a hose added which makes it easier for the operator to use. Initially the hose will need to be purged with grease.

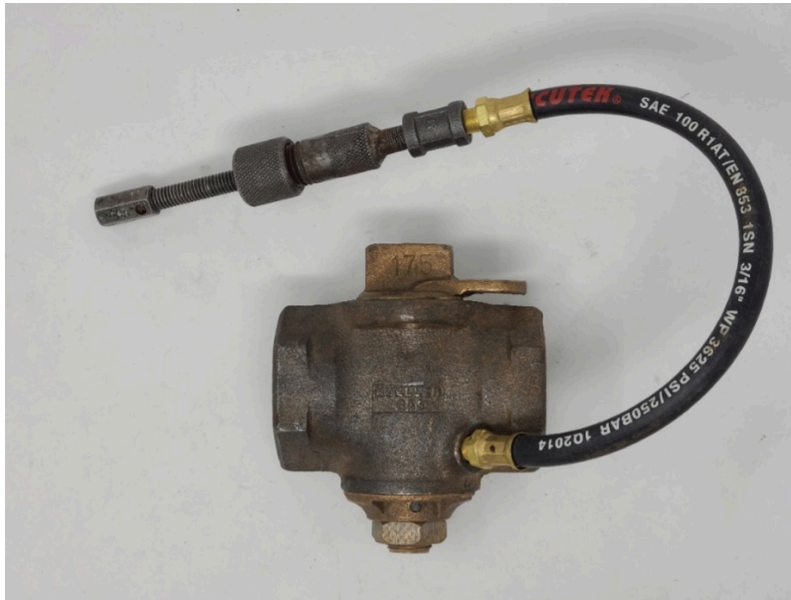

Figure 7. Sealant screw injection tool with hose extension

Another type of lubrication fitting is the combination button head/ screw fitting which enable the connection of the lubricating hand gun for the initial lubrication (Figure 8). Further relubrication can be done by screwing down the fitting with a wrench. When the fitting is finally turned into the valve as far as it will go, it indicates additional sealant should be added. The sealant fitting must be backed out a ways and sealant injected into the fitting's reservoir, or remove the fitting and insert another stick of sealant.



Figure 8. Combination giant buttonhead/lubescrew fitting

If it is OK to interrupt the gas flow, then turning the valve on and off while lubricating helps distribute

the lubricant more evenly. Soap leak test the top and bottom plug seams as well as the lube port when finished.



Now complete Self-Test 1 and check your answers.

## Self-Test 1

### Self-Test 1



An interactive H5P element has been excluded from this version of the text. You can view it online here:  
<https://opentextbc.ca/plumbing4b/?p=38#h5p-5>

## Media Attributions

- Figure 1. “Valve markings” by Rod Lidstone is licensed under a [CC BY-NC-SA licence](#).
- Figure 2. “Ball valve fail safe position” by Camosun College is licensed under a [CC BY-NC-SA licence](#).
- Figure 3. “[Wrenching ball valves](#)” from Boshart Industries is used for educational purposes under the basis of fair dealing.
- Figure 4. “Tightening ball valve packing nut” by Rod Lidstone is licensed under a [CC BY-NC-SA licence](#).
- Figure 5. “Button head grease fitting and coupler” by Rod Lidstone is licensed under a [CC BY-NC-SA licence](#).
- Figure 6. “Loading lubrication stick into screw injection tool” by Rod Lidstone is licensed under a [CC BY-NC-SA licence](#).
- Figure 7. “Sealant screw injection tool with hose extension” by Rod Lidstone is licensed under a [CC BY-NC-SA licence](#).
- Figure 8. “Combination giant buttonhead/lubescrew fitting” by Rod Lidstone is licensed under a [CC BY-NC-SA licence](#).

---

## Learning Task 2

### Installing Gas Pressure Regulators

Although this learning task focuses on the physical act of installing regulators it is critical that the proper regulator has been chosen for the application. Future studies will explain the factors and procedures for gas regulator selection and sizing.

For a gas regulator to perform as expected you must install it properly in the piping system. The installation must meet the requirements of the Gas Code and conform to manufactures installation instructions. To ensure that the regulator is installed properly, the installation process must be properly planned.

Here are some common Gas Code terms that will also be used in this learning task.

- Accessory — a part capable of performing an independent function and contributing to the operation of the appliance that it serves.
- Bleed vent — a vent where the expiration or inspiration of air or gas occurs from or to one side of a diaphragm of any accessory, component, or equipment such as a valve, pressure regulator, or switch.
  - Vent limiter – A means that limits the flow of gas from the atmospheric diaphragm chamber to the atmosphere in the event of a diaphragm rupture. This may be either a limiting orifice or a limiting device.
- Certified — investigated and identified by a designated testing organization as conforming to recognized standards, requirements, or accepted test reports.
- Component — an essential part of an appliance or equipment.
- Concealed piping or tubing — piping or tubing that, when in place in a wall, floor, or ceiling of a finished building, is hidden from view and can only be exposed by use of a tool. The term does not apply to piping or tubing that passes directly through a wall or partition.
- Overpressure protection device — a device that under abnormal conditions will act to reduce, restrict, or shut off the supply of gas flowing into a system to prevent gas pressure in that system from exceeding the rated pressure of the system components.
- Readily accessible — capable of being reached quickly for operation, renewal, servicing, or inspection, without requiring climbing over, or the removal of, an obstacle or the use of a portable ladder.
- Relief device — a device designed to open to prevent a rise of gas pressure in excess of a specified value due to an emergency or abnormal conditions.
- Internal relief valve — a pressure relief valve that is built into the body of the diaphragm assembly of a pressure regulator.
- Line relief valve — a relief valve installed in the piping or tubing system downstream of a

final-stage pressure regulator that is not equipped with an internal relief valve.

- Ventilated space — a space where there is an air change by means of natural ventilation or mechanical means, or where the space communicates with the rest of the structure by means of permanent openings.

## Over Pressure Protection

Any time a pressure reducing regulator is installed that supplies gas from any system to another system with a lower maximum allowable operating pressure some form of over pressure protection (OPP) is required to protect the downstream components.

The gas code stipulates that, for piping systems with a supply pressure over 2 psi, a line pressure or high pressure regulator must be provide with OPP.

The gas code identifies the following methods of OPP:

- Overpressure relief device — an overpressure protection device that functions by discharging gas from the downstream system.
- Monitoring regulator — an overpressure protection device that functions as a second gas pressure regulator in series with the primary gas pressure regulator.
- Overpressure shut-off device — an overpressure protection device that functions by completely shutting off the flow of gas into the downstream system.

## Relief devices

A relief valve is a device that vents process fluid to atmosphere to maintain the pressure downstream of the regulator below the safe maximum pressure. Relief valve exhaust must be directed or piped to a safe location. The basic types of relief vales are:

- Pop types
- Direct operated relief valves
  - Internal relief
- Pilot operated relief valves

### Pop-type

The pop type relief valve is the simplest form of relief (Figure 9). When the pressure increases above the set pressure the pop relief valves will go to the wide-open position until the overpressure condition is reduced. This type of relief valve is almost exclusively used by natural gas distributors upstream of the building meter set.

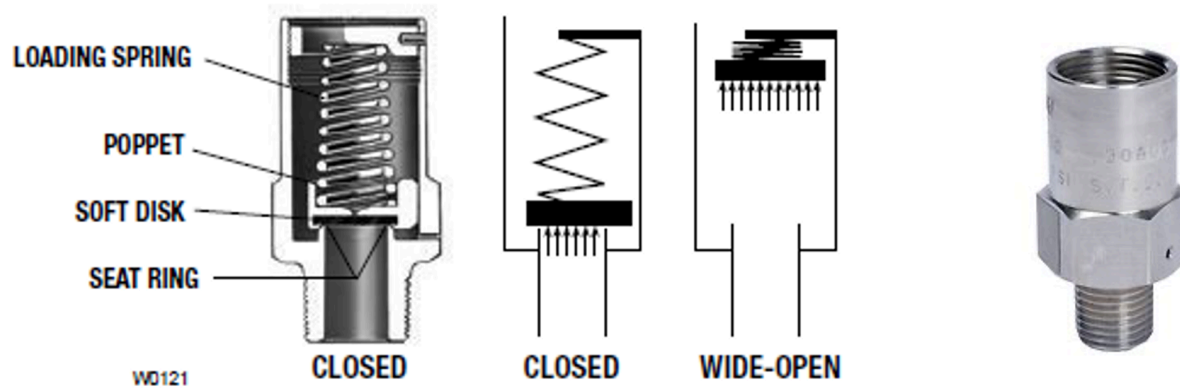

Figure 9. Pop-type relief valve

### Direct operated

Direct-operated relief valves provide throttling action and require less pressure buildup to open than the pop-type. A direct operated relief valve looks like an ordinary direct-operated regulator except that it senses upstream pressure rather than downstream pressure. And, it uses a spring-to close rather than a spring-open action.

It contains the same essential elements as a direct-operated regulator:

- A diaphragm that measures system pressure
- A spring that loads downward force onto the diaphragm and determines the relief setpoint
- A valve that throttles the relief flow



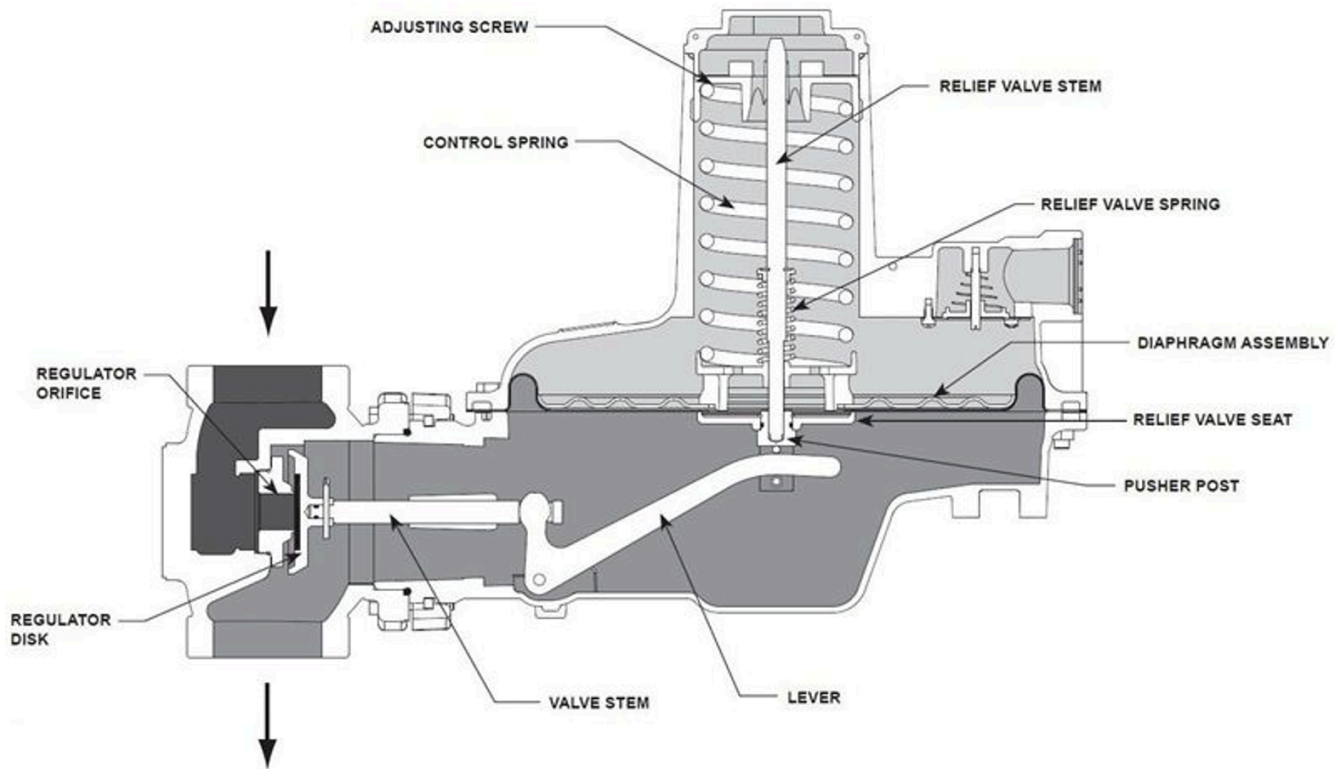

Figure 11. Direct operated regulator with internal relief

### Pilot operated

Pilot-operated relief valves have two direct-operated relief valves; a pilot and a main relief valve. The pilot relief increases the effect of changes in inlet pressure on the main relief valve. The pilot-operated relief valves have the most accuracy, but are also the most complicated and expensive type of relief. They are typically found on applications requiring high capacity and low pressure buildup.

During normal operation, the pilot is closed allowing loading pressure to register above the main relief valve's diaphragm. This pressure is opposed by inlet pressure acting on the bottom of the diaphragm.

If inlet pressure rises above setpoint, the pilot valve opens, exhausting the loading pressure. If loading pressure is reduced above the main relief valve diaphragm faster than it is replaced through the pilot fixed restriction, loading pressure is reduced and inlet pressure below the diaphragm will cause the main regulator to open.

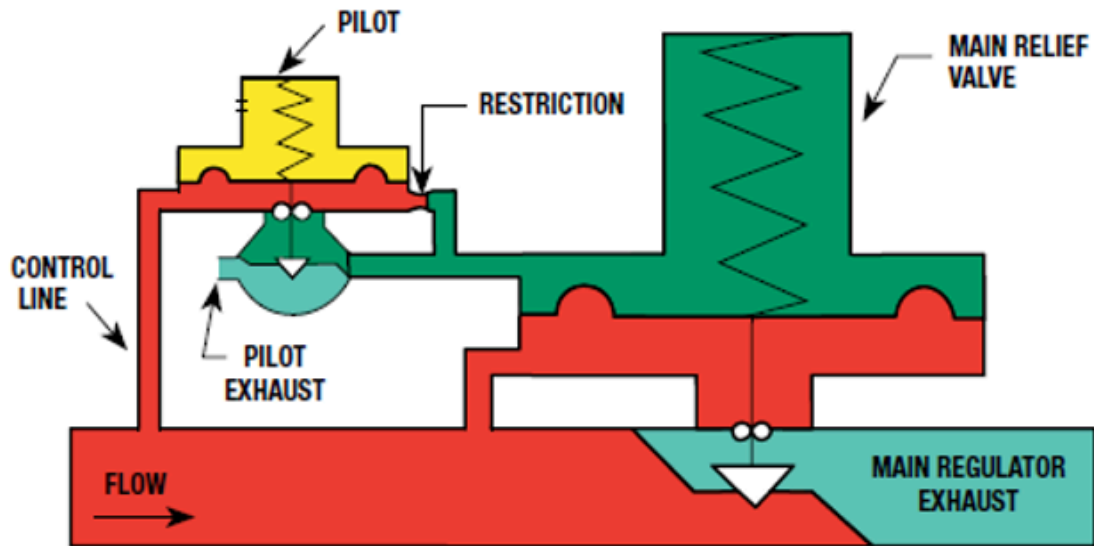

Figure 12. Pilot operated relief valve

When a pressure regulator has internal relief or a pressure relief valve is used, they must be vented to the outdoors to a safe location.

### Monitoring regulator

Over pressure protection by monitoring is also called pressure limiting. Pressure limiting is overpressure control by containment as there is no venting to atmosphere required. The gas code defines OPP by monitoring regulator as a second gas pressure regulator in series with the primary gas pressure regulator. This definition is rather narrow as there are two common methods of OPP that have use two regulators installed in the same pipeline, and one of these methods is commonly referred to by industry as a monitor regulator. Pressure limiting regulators are listed as an acceptable overpressure protection device and are commonly available as preassembled certified units for 5 psi line pressure regulators (Figure 13).



Figure 13. Line pressure regulators

The image on the left in Figure 13 is a series regulation system also known as a two stage or two cut system. In this setup the first (upstream) regulator maintains an inlet pressure to the second regulator

that is within the maximum allowable operating pressure of the downstream system. If either regulator should fail, the resulting downstream pressure maintained by the other regulator would not exceed the safe maximum allowable pressure for the downstream system.

The image on the right in figure 13 is a monitoring regulator setup. The only difference in configuration between series regulation and monitors is that in monitor installations, both regulators sense the furthest downstream pressure. Thus, the upstream regulator must have a sensing control line. The monitor regulator setpoint is slightly higher than the worker regulator therefore it will only start regulating if the worker regulator fails.

Depending upon the regulator setpoints monitor regulator systems may be referred to as either:

- Upstream wide-open monitor
- Downstream wide-open monitor

### Overpressure shut-off (OPSO) device

The shutoff device also accomplishes overpressure protection by containment. If an overpressure condition exists, the gas is shut off completely until the cause of the malfunction is fixed and the device is manually reset. The schematic in figure 14 indicates a spring loaded shutoff device sensing the pressure downstream of the regulator.

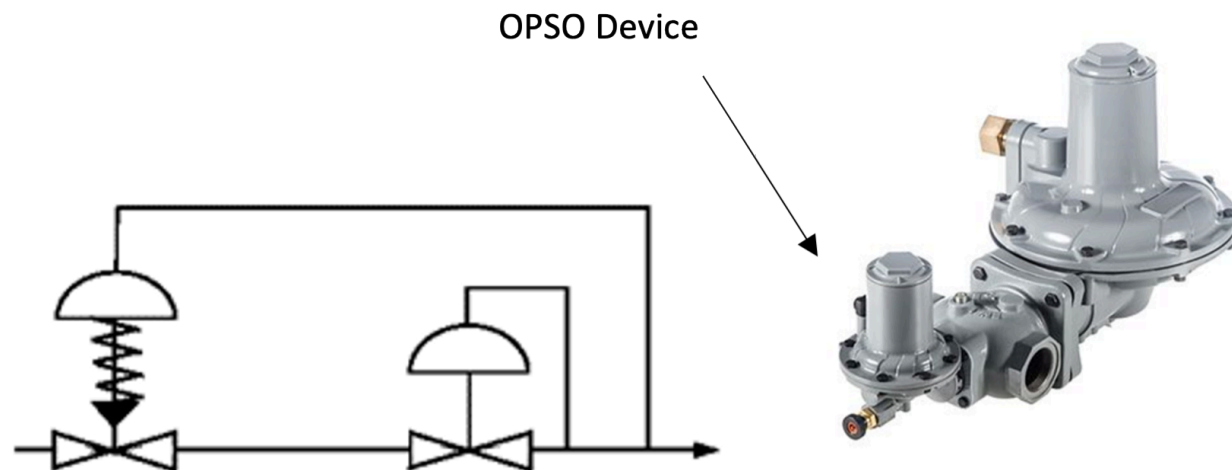

Figure 14. Overpressure shut-off

### Vent limiters

Small appliance regulators and servo regulator on combination gas valves will have a bleed vent opening with an internal orifice, usually about a #78 drill size (Figure 15 left). This opening is large enough to enable the regulator diaphragm to breath adequately but small enough to limit the amount of gas that would escape in the event of a diaphragm rupture. The threaded connection under the cap can be used to pipe the vent to away if the regulator is installed in a non-ventilated space. The vent opening is usually covered by a loose-fitting cap to prevent dirt from entering the opening (Figure 15 right).

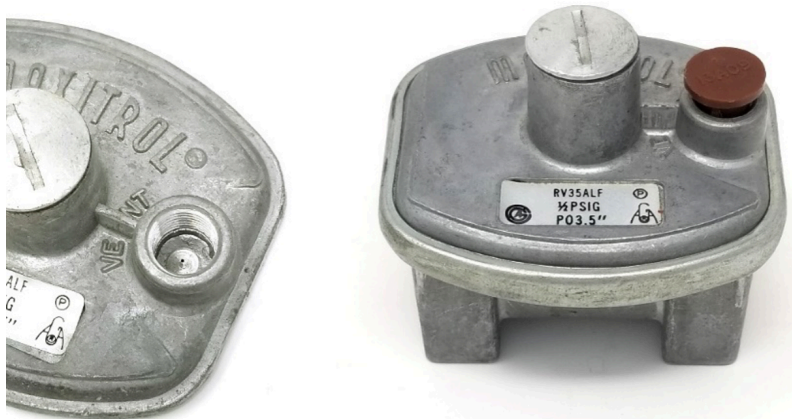

Figure 15. Bleed vent openings

Larger regulators will have a larger bleed vent orifice to accommodate the greater amount of air that must move in and out through the bleed vent. This larger orifice will not adequately limit the escape of gas in the event of a diaphragm rupture. Therefore, when these regulators are installed indoors they must either be vented to outdoors or have some type of vent leak limiter installed. Figure 16 shows a fixed vent limiting orifice accessory sitting on the regulator, notice the regulators larger internal orifice size. The vent limiting orifice has a very small orifice opening that will restrict the air flow which will delay the regulators reaction time. To accommodate this slower reaction time the manufacture will reduce the maximum rated individual appliance capacity the regulator when using this accessory. If this regulator was required to respond at its full capacity for any single appliance then the vent limiting orifice could not be used and the vent would need to terminate outside or use an automatic vent leak limiting device.

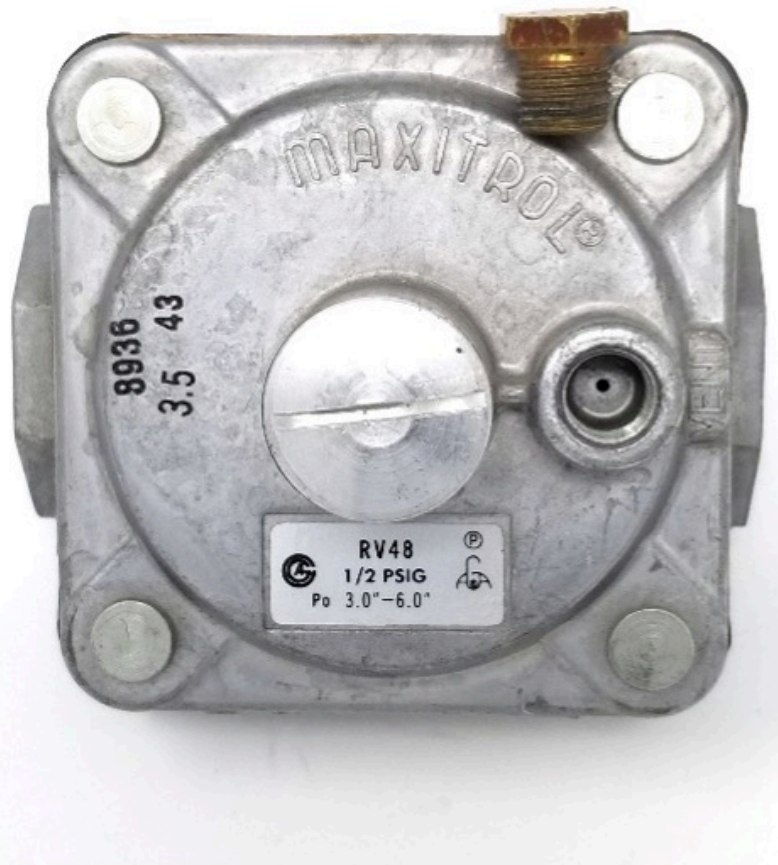

Figure 16. Bleed vent with an external vent limiting orifice

### Automatic leak limiting devices

Special leak limiting devices are designed to ensure fast diaphragm response by allowing the free movement of air under normal regulator operating conditions. However, if the diaphragm ruptures, the high pressure flow of gas causes the ball check or disc check to limit the flow of gas (Figure 17). The leak limiting device must be in the vertical position or the ball check could roll into the closed/limiting position causing the regulator to not operate properly.

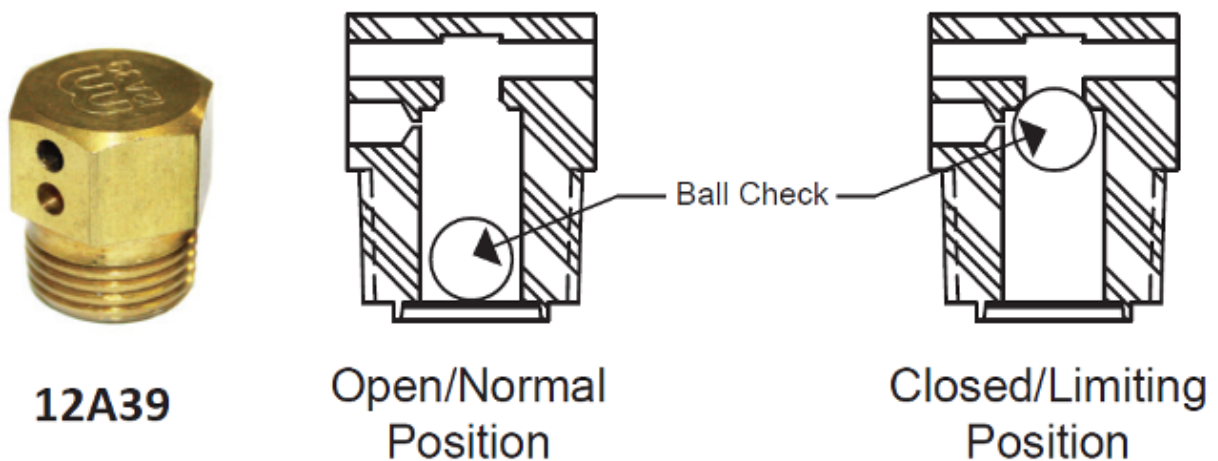

Figure 17. Leak limiter

Vent leak limiting devices should not be used outdoors, if they are exposed to the environment they may become clogged by moisture or insects. Manufacturers may have more than one leak limiter available that fits the regulator, it is important that the proper model specified by the manufacturer is use.

In order to keep the leak limiter vertical most manufactures will require the regulator to be mounted in the horizontal upright position. Some regulators are approved for use in the vertical position, for example Figure 18 shows a regulator designed with two vent connections which enable the regulator to be installed either vertically or horizontally using the appropriate location for the vent limiter and a plug in the other.



Figure 18. Multi position 2 psi line pressure regulator

Other manufactures may have a 90 degree external vent limiter adapter available for vertical or rolled regulator orientations (Figure 19). Installers must use these manufactured certified adapters only; it is not acceptable to install you own pipe and or fittings between the regulator and the vent limiter.

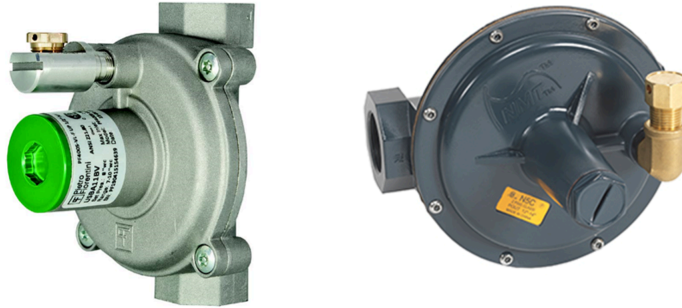

Figure 19. External vent limiter adapters

## General regulator installation guidelines

If installation is planned properly, the process will usually proceed smoothly.

### Planning

- Verify that the regulator matches the one that was selected and ordered. Check the make, model, and pressure range.
- If you have not installed this exact regulator before be sure to read the manufacturer's guidelines for installing the regulator.
- As part of the design and selection of the regulator a sketch of the piping system should have been created. When arriving at the site, check the sketch to ensure that the intended location of the regulator is suitable.
- Regulator location considerations include:
  - place the regulator so that it can be easily serviced and there is room for a manual shut-off valve immediately upstream of the regulator and a union for future removal of the regulator.
  - flow turbulence makes it difficult for the regulator to properly operate. A general rule of thumb when installing any pressure or flow sensitive control is to allow 10 pipe diameters of straight pipe on the inlet side and 5 pipe diameters on the outlet side of the control to insure laminar flow in and out of the control. Always check the regulator manufacturer's literature, some manufactures require up to 18 inches (450 mm) of straight pipe on either side of the regulator before any change of direction or change of pipe size.
  - the regulator can not be in a concealed location
  - ensure that there is enough room to install a vent and sensing line if they are required.
  - regulators equipped with vent leak limiting means must be installed in a ventilated space

- regulators vents must terminate outdoors, with specific clearances from other building openings, as specified in the gas code
- check gas code for additional rules regarding regulator locations
- Has the piping been pressure tested? Regulators that are not rated for the required test pressure shall not be connected to the piping system under test.

## Installing

- Check the following items to ensure that the basic requirements for the piping have been met:
  - Approved materials have been used for the piping.
  - The piping is in an appropriate location.
  - The sizing is adequate for present and future appliances.
- The piping must be properly supported so that it is aligned and does not put stress on the regulator. This could crack or warp the body of the regulator and prevent it from operating correctly or cause it to leak gas.
- If using threaded joints:
  - clean the pipe threads and apply pipe lubricant sparingly to male threads, being careful to start a few threads from the end of the pipe. Loose debris or pipe sealant may become lodged in the valve/seat area of the regulator and inhibit the regulator's ability operate.
  - do not over tighten the pipe threads into the regulator, as this can damage the regulator body.
  - position wrenches so that torque is not transmitted through the regulator body
- The direction of flow through a regulator is critical for its proper operation. The flow direction will be shown by an arrow or by the words "inlet" and "outlet" at each end of the regulator. If the regulator is installed backwards it may be damaged and the diaphragm will hold the seat closed resulting in no flow.
- Regulators installed in outdoor locations will require extra protection to protect the bleed vent from the elements and debris.
- Most regulators are suitable for multi-position mounting. But if the regulator is supplied with a leak limiting device this may require that the regulator be mounted in a horizontal upright position.
- When venting is required, remove the cover from the bleed vent and use a nipple and a union at the connection, then connect the vent pipe, being careful to locate the outlet in a safe place, in accordance to all local codes, standards, and requirements.

## Venting regulators

Section 5.5 of the CSA B149.1 pertains to venting of regulators. It specifies what material can be used

for the vent, the size of single and combined vents, and permissible locations for vent terminations. Some of the code rules are summarized here but these should be compared to the actual language in the code. Compliance with the regulator manufacturer's instructions is also required.

For dedicated bleed vent lines serving a single regulator, the size of the vent must be at least equal to the nominal pipe size of the vent outlet of the pressure regulator, but its inside diameter must not be less than 0.25 inches (6 mm). Notwithstanding manufacturer's instructions if the vent line is longer than 15 m (50 ft) and it is serving a line pressure regulator or a relief valve it must be increased by one pipe size diameter for every (15 m) 50 ft or part thereof that the vent line extends beyond the initial (15 m) 50 ft. This increase must be made at the regulator vent outlet, which should include a union at the connection to the regulator.

Individual vent lines may be combined to a single (common) vent line, but the size of the common vent depends on the types of devices that are common vented. For the common vent serving regulators without internal relief the common vent must be sized to have an area of not less than twice the total area of the connected bleed vents. For a common vent serving regulators with internal relief the common vent must have an area equal to the largest relief opening plus 50% of the total area of the other relief valve openings.

### **Regulator vent terminations**

The gas code also defines how and where the vent terminates outdoors. The vent must terminate outdoors pointing downwards and be equipped with a means to prevent the entry of water, insects, or foreign material.

When determining where to terminate the vent to outdoors there are many clearance requirements that must be considered, such as building openings or exhaust vents. Figure 20 summarizes the clearance requirements as listed in the gas code for natural gas regulator vents. The diagram displays these requirements as they would relate to the vent outlet of a service regulator but these same clearances would apply to the outside termination of a vent from an inside the building regulator.

- For the area shown as letter A, clearance of 3 ft (1 m) is required to:
  - Electrical outlet, electric meter, open flame barbeque, or other source of potential ignition
  - Building openings, including all windows and doors
  - Passive atmospheric air intake
  - Appliance exhaust vent from a non-gas appliance or a gas dryer
- For the area shown as letter B, clearance of 10 ft (3 m) is required to:
  - Mechanical (fan assisted) air intakes
- For the area shown as letter C, no gas appliance exhaust vents may be terminated.

For vents serving propane regulators the clearances to passive air intakes and ignition sources increase from 3 ft (1 m) to 10 ft (3 m).

There are also clearance reduction allowances listed in the gas code for regulator vents that have a restricted amount of gas that could be expelled.

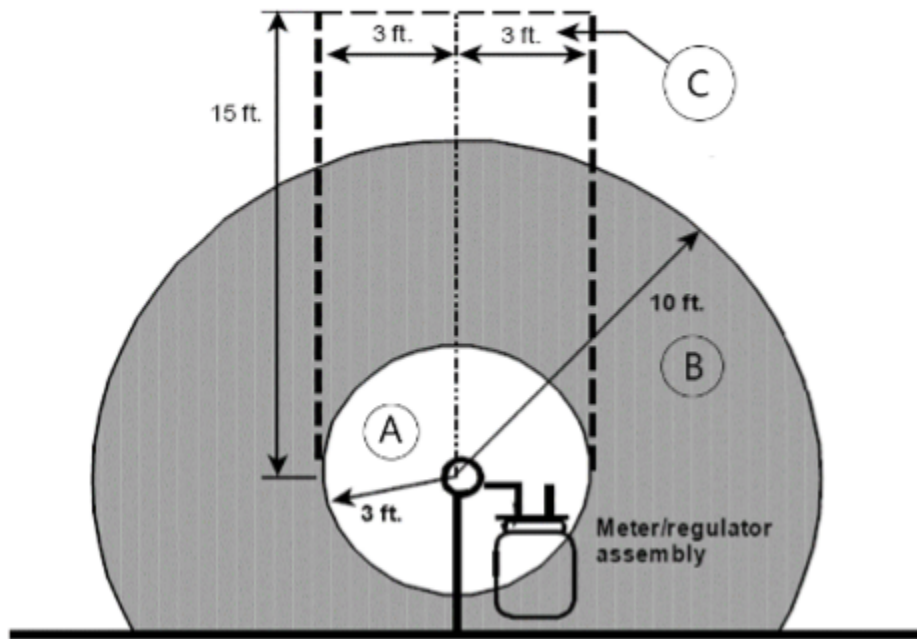

Figure 20. Natural gas regulator vent clearances

The minimum clearance must be maintained regardless if the feature is located around an outside corner. In these cases, measure as if using a string pulled tight from the outlet to the feature (Figure 21).

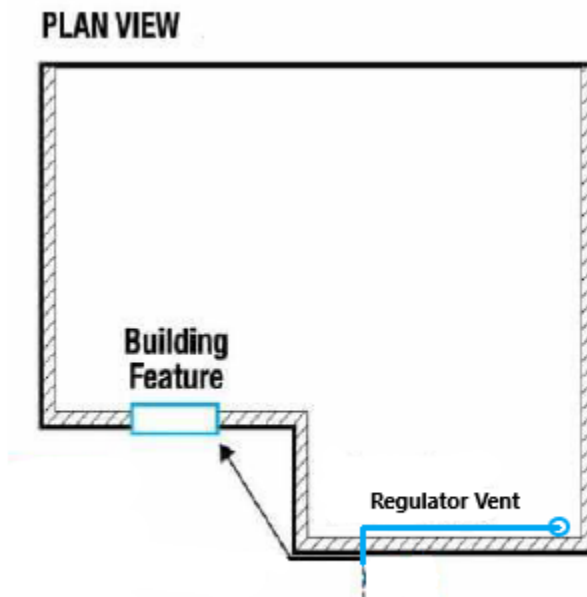

Figure 21. String line measuring

## System start-up

Whenever introducing or restoring the gas supply to the pressure regulator, open the manual valve very slowly in the line supplying the pressure regulator. Soap test any connections that were not include in the piping system pressure test.

The regulators operation must be checked to ensure it is:

- Receiving the proper design inlet pressure at static and operating conditions
- Delivering the setpoint outlet pressure at static and operating conditions
- Maintain the maximum outlet lock-up pressure without any creepage at static conditions

Before starting the appliances check the regulator inlet and outlet static pressures. After perform the appliance start-up procedures cycle the appliance on and off multiple times to check the operating pressure setpoints and the lock-up pressure. For modulating appliances, be sure to cycle from high fire to low fire while observing operating pressures.



Now complete Self-Test 2 and check your answers.

## Self-Test 2

### Self-Test 2



An interactive H5P element has been excluded from this version of the text. You can view it online here: <https://opentextbc.ca/plumbing4b/?p=40#h5p-6>

## Media Attributions

- Figure 9. “Pop-type relief valve”.
  - “[Pop type relief valve](#)” (Left) from Carremm Controls is used for educational purposes under the basis of fair dealing.
  - “Fisher™ H120 Series Relief Valves” (Right) from Fisher and Emerson is used for educational purposes under the basis of fair dealing.

- Figure 10. “[Direct operated relief valve](#)” from Fisher and Emerson is used for educational purposes under the basis of fair dealing.
- Figure 11. “[Direct operated regulator with internal relief](#)” from Emerson is used for educational purposes under the basis of fair dealing.
- Figure 12. “[Pilot operated relief valve](#)” from Fisher and Emerson is used for educational purposes under the basis of fair dealing.
- Figure 13. “Line pressure regulators”.
  - “[GAS PRESSURE REGULATOR](#)” (Left) from Maxitrol is used for educational purposes under the basis of fair dealing.
  - “Line pressure regulator” (Right) by Camosun College is licensed under a [CC BY-NC-SA licence](#).
- Figure 14. “[Overpressure shut-off](#)” from Emerson is used for educational purposes under the basis of fair dealing.
- Figure 15. “Bleed vent openings” by Camosun College is licensed under a [CC BY-NC-SA licence](#).
- Figure 16. “Bleed vent with an external vent limiting orifice” by Camosun College is licensed under a [CC BY-NC-SA licence](#).
- Figure 17. “Leak limiter” from Maxitrol is used and adapted for educational purposes under the basis of fair dealing.
- Figure 18. “Multi position 2 psi line pressure regulator” by Camosun College is licensed under a [CC BY-NC-SA licence](#).
- Figure 19. “External vent limiter adapters”.
  - “[GOVERNOR & PF400](#)” (Left) from Pietro Fiorentini is used for educational purposes under the basis of fair dealing.
  - “[Line and Service Regulators](#)” from Norgas Controls is used for educational purposes under the basis of fair dealing.
- Figure 20. “Natural gas regulator vent clearances” by Camosun College is licensed under a [CC BY-NC-SA licence](#).
- Figure 21. “String line measuring” by Camosun College is licensed under a [CC BY-NC-SA licence](#).

# Competency B3: Commission Fuel Gas Delivery Systems

Before any gas piping system is ready for service it must be carefully tested and purged. Testing and purging must be performed in accordance with the requirements of the applicable codes and regulations.

## Learning Objectives

After completing the learning tasks in this competency, you will be able to:

- Interpret codes as they apply to testing and purging gas piping systems
- Describe piping and tubing pressure testing procedures
- Describe purging procedures for 2 psi and lower systems with piping and tubing 2 inch diameter and smaller



---

## Learning Task 1

### Describe Gas Piping and Tubing Pressure Testing

After installing a gas piping system, you must pressure test it. If any section of the piping system is to be enclosed or concealed a test must be performed before closing it in. To test for tightness, the piping may be filled and pressurized with air or inert gas. Never use oxygen for testing. Oxygen will combine with oils and spontaneous combustion will take place.

### Gas code test requirements

The CSA B149.1 Gas installation code specifies the pressure test requirement for piping and tubing systems extending from the termination of the utility installation or from the distributor's propane tank. The Section 6 pressure test table stipulates the required test pressure and duration based on the systems working pressure, size, and length.

For example by referencing the code table we find that, a 2-psi system 50 meters in length will require a 15-psi pressure test for a minimum of 15 minutes. Whereas a 2-psi system 70 meters in length will require a 15-psi pressure test for a minimum of 60 minutes.

### Equipment

For an air test, you can pressurize the piping system by using a hand pump or an air compressor. When performing an inert gas pressure test use a pressure regulator and pressurized gas cylinders. Temporary test connection piping, fittings, hoses will need to be connected and must include an isolation valve and the appropriate test gauge.

The pressure gauge, must be a minimum of 3 in. (75 mm) diameter and the maximum range must exceed the test pressure by at least 15% but not more than 300%. The pressure increments of the gauge or equivalent device shall not be greater than either 2 psig (14 kPa) or 2% of the maximum dial reading of the gauge, whichever is less. For example, a test gauge to administer a 15 psi test could not have a maximum range of at least 17.25 psi and not more than 45 psi. The 30 psi gauge shown in figure 1 would be ok to use as its increments are 0.5 psi and the maximum increment size for a 30 psi gauge must be 0.6 psi (30 psi x2%). This follows the rule of thumb: your test pressure should fall in the middle third of your gauge.

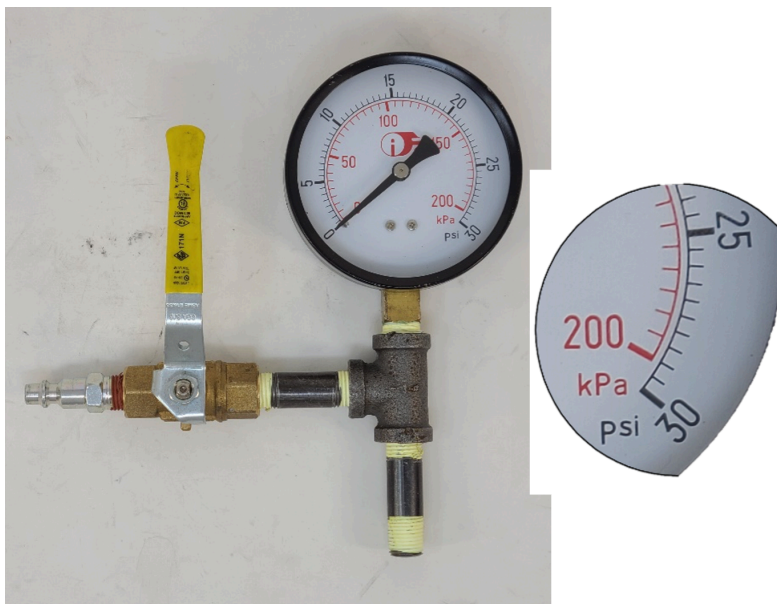

Figure 1. Pressure test assembly

## Test Procedures

During installation of piping and tubing and before pressure testing, visually inspect piping and tubing for cuts, abrasion, and any other defect that may cause leaking or failure of the system when it is under pressure. As stated the gas piping must be pressure tested after being installed and:

- before connecting of any appliances (stage 1)
- after the appliances are connected prior to operation (stage 2)

### Prior to connecting the appliances

Perform the first pressure test after the installation of the piping system and before the connection of any appliances to the system. Before testing, isolate or remove any components of the system that have a pressure rating below the test pressure to prevent any damage to these components. For example, a line pressure regulator usually does not have a high enough pressure rating to be included in the pressure test.

Follow these steps to perform the stage 1 test (Figure 2):

- Isolate the piping system or section that you will test by capping or plugging all open ends.
- Insert a pressure gauge at one end of the system. Include a separate shutoff valve at the gauge connection so the pressure supply hose can be removed.
- Pressurize the system with air or inert gas (nitrogen or carbon dioxide) to the specified test pressure.
- Monitor the pressure for the specified minimum duration. Be conscious of any temperature changes that will affect the pressure reading. If a pressure recorder is used it must be

calibrated to the same increment requirements as the pressure gauge.

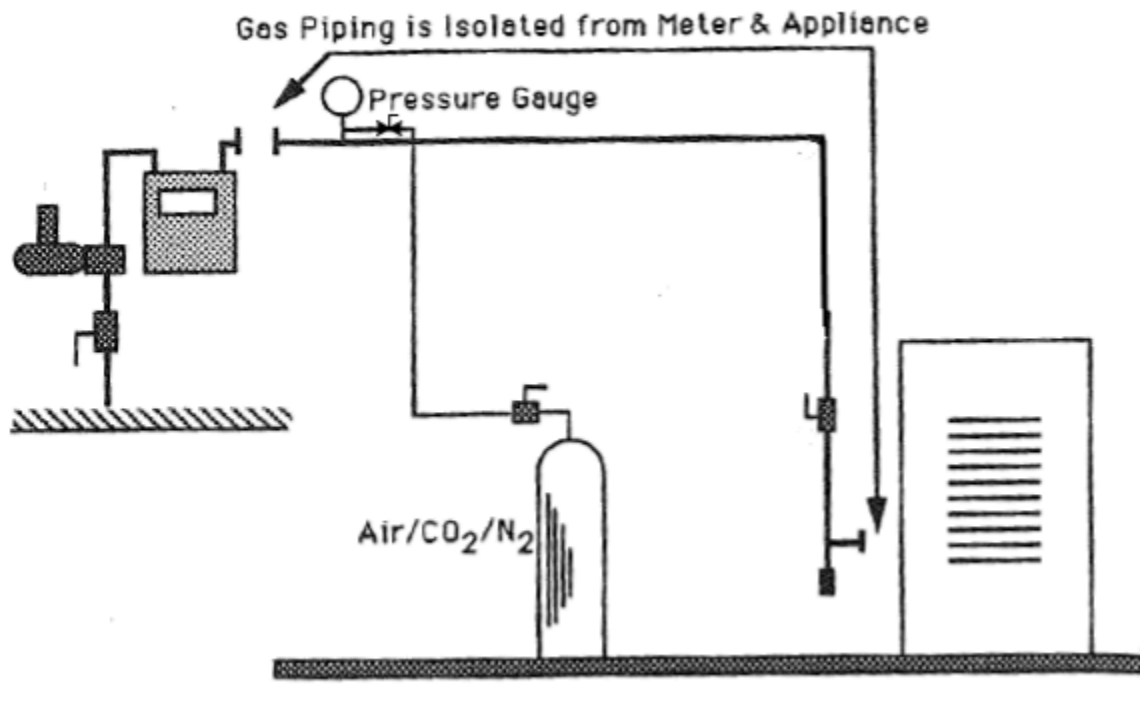

Figure 2. Stage 1 pressure test

If a drop in pressure is noticed, you will need to search for the location of the leak, typically with a soap solution leak detector.

#### Inert gas volume requirements

Most often for smaller pipe sizes the pressure test will usually use readily available compressed air. Larger commercial and industrial system will often use inert gas for the pressure test as it is also required for the purging procedure. If an inert gas is used you will need to determine the number of cylinders of compressed gas that are required. A typical cylinder, about 5' tall (Figure 3), can hold about 230 cubic feet of nitrogen gas at atmospheric pressure, if it is filled to the maximum operating pressure of 2 200 psig. Although this volume will be reduced based on the system test pressure being used.



Figure 3. Nitrogen cylinders

Using Boyles' Law we can determine the reduced volume of gas available for a 15 psig (approx. 30 psia) pressure test.

Example:

$$\begin{aligned}
 P_1 V_1 &= P_2 V_2 \\
 14.37 \times 230 &= (14.73 + 15)V_2 \\
 \frac{3387.9}{19.73} &= V_2 \\
 V_2 &= 171.7 \text{ ft}^3
 \end{aligned}$$

Given that every 1 foot length of 2" pipe only has a volume of .022 ft<sup>3</sup>, one cylinder will be more than adequate for pressure testing a typical residential gas system. For larger and longer piping systems with higher test pressures additional cylinders may be needed, especially when additional volumes are required for purging operations.

## After the appliances are connected

After the gas appliances are installed, perform the Stage 2 test (Figure 4):

- Install a pressure gauge or manometer at the gas meter outlet, include a bleed valve at the gauge connection. The manometer or pressure gauge that you used for this test should be in 1 in. w.c. (250 kPa) increments or less. If the system has any line pressure regulators, additional pressure gauges or manometers should be connected to check the regulator setpoint and lock-up pressures.
- Visually check the entire system to ensure that all openings have been connected, the appliance shut-off valve is open, the appliance control valve is closed, and the gauge bleed valve is closed.
- Slowly open the meter valve and listen for the gas flow to stop. Monitor the gas meter test dial to ensure that no gas is escaping which would indicate an opening or large leak.
- At this time the service and line pressure regulators' static pressures should be checked to ensure the outlet pressure lockup settings are not being exceeded, as this could damage downstream components.
- Turn off the meter valve to capture the gas under pressure (Figure 3). The gas pressure indicated on the manometer, or pressure test gauge, must be maintained for a minimum of 10 minutes.
- Upon successfully completing the 10 minute pressure test, perform a leak test on all untested control valves and appliance piping using non-corrosive bubble leak detector solution under normal operating pressure to ensure they are gas tight.
- Finally check to ensure there was no meter valve seepage that may have masked a system leak. The valve may be seeping gas as a result of dried and hardened valve grease. With the static pressure still captured in the system, and the meter valve turned off, release a small amount of gas through the gauge test assembly bleed valve to drop the pressure slightly. If after this action the gas pressure increases slowly the meter valve is seeping gas. The meter valve will need to be serviced before the stage two test is repeated.

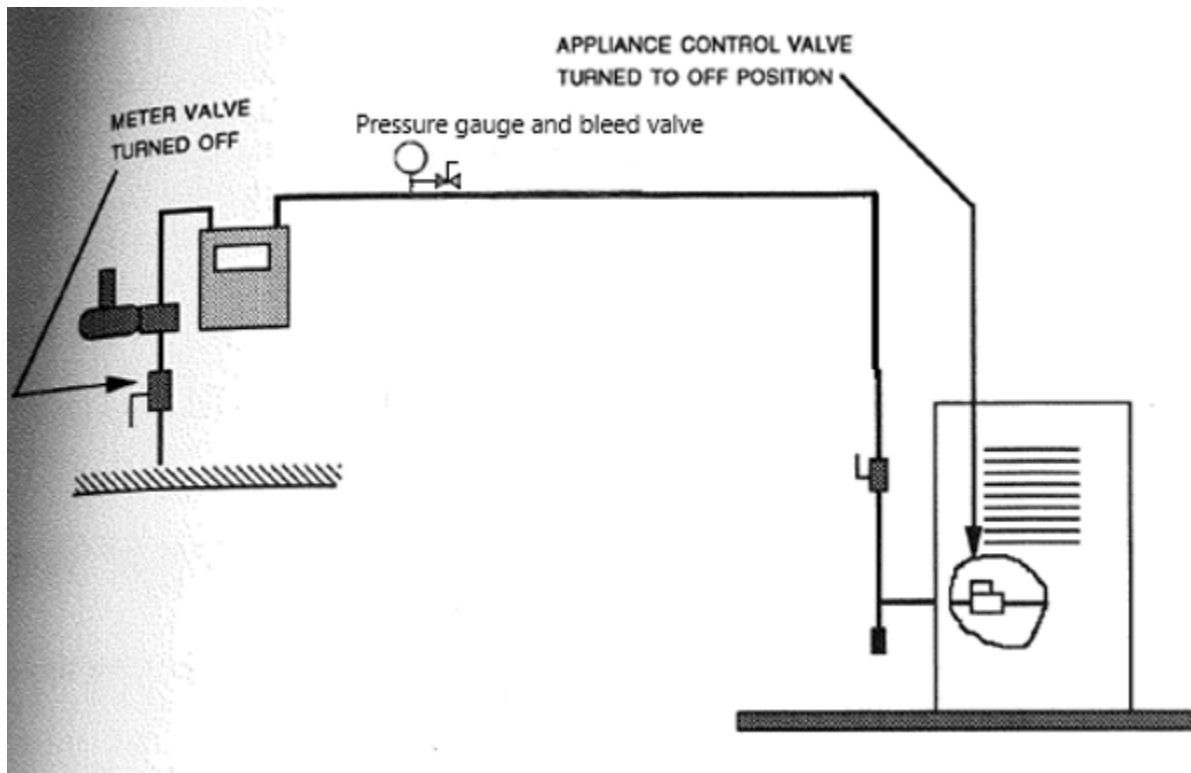

Figure 4. Stage 2 pressure test

## Propane system tests

On propane systems the test before the installation of the appliances is performed in the same way as for natural gas.

The test after the appliances are connected will differ for separate, two stage regulation systems. Additional pressure gauges or manometers will be required as both pressure stages must get a 10-minute static pressure test and a valve seepage test.

## Leak detection

The best way to search is by using a bubble leak detector solution (aka soap test). A leak will cause the solution to create bubbles (Figure 4) at the joint or fitting. Specially designed bubble leak detector solutions that are made for this purpose are recommended. They have better coating and bubbling characteristics than dish detergent and are non-corrosive. Sometimes the location of the leak may be obvious, but other times it will not (Figure 5). In those cases, you will need to cover as many of the fitting joints with the solution as possible to locate the potential leak(s). Be aware of the test pressure as you may need to add additional pressure to the lines to make up for leak loss.



*Figure 5. Leaking joint*

It is important to thoroughly examine the leaking joint once it has been located. The type of connection may play a big role in the cause of the leak. While it is possible that a fitting is simply loose, there are several other possibilities including a crack in a pipe, bad threads, a poor flare when dealing with copper lines, or even a bad seal due to a poorly cut CSST gas line. Make sure to bleed off the pressure before fixing a leak. Once the leak has been repaired you must repeat the pressure test. Clean up any leak detector residue with a wet rag when you have completed the tests.

## **Final leak tests**

Any temporary test connections points must be plugged or capped and soap tested. Additionally, when the appliance is started all valve train connections downstream of the control valve must be soap tested.



Now complete Self-Test 1 and check your answers.

## Self-Test 1

### Self-Test 1



An interactive H5P element has been excluded from this version of the text. You can view it online here: <https://opentextbc.ca/plumbing4b/?p=44#h5p-7>

## Media Attributions

- Figure 1. “Pressure test assembly” by Rod Lidstone is licensed under a [CC BY-NC-SA licence](#).
- Figure 2. “Stage 1 pressure test” by Rod Lidstone is licensed under a [CC BY-NC-SA licence](#).
- Figure 3. “Nitrogen cylinders” by Rod Lidstone is licensed under a [CC BY-NC-SA licence](#).
- Figure 4. “Stage 2 pressure test” by Rod Lidstone is licensed under a [CC BY-NC-SA licence](#).
- Figure 5. “Leaking joint” by Rod Lidstone is licensed under a [CC BY-NC-SA licence](#).

---

## Learning Task 2

### Purging Low Volume Gas Piping Systems

After the gas lines have been pressure tested they must be purged to eliminate the risk of a forming a dangerous flammable air/gas mixture within the pipeline. Purging the gas line means removing the air from the pipeline by using the pressurized gas supply to force it out.

On high volume commercial and industrial gas systems where the appliances may have inputs over 400 000 Btu/h (120 kW) the purging procedures will be performed or supervised by a Class A gas fitter. These systems will often have piping over 2 psig and or over 2" nominal size which will need to first be purged with an inert gas. The inert gas is needed to separate the air in the piping from the incoming gas and the flow speed is controlled at supervised purge burner located outdoors.

Low volume residential and small commercial gas piping systems may be purged to an indoor space. Check the gas code to verify the conditions in which indoor purging are allowed.

### Indoor purging procedures

Before the low volume system is purged it is assumed the appliances are connected, the stage two leak test has been completed, and the system has been charged with gas pressure. Additionally, the service and line pressure regulators' static pressures have been checked to ensure the appliance inlet pressures are correct (Figure 6).



Figure 6. Checking appliance control valve inlet pressure

When conditions allow it, indoor purging may be performed in one of two ways:

- To an open burner such as a range
- Using a purging assembly with an automatic shutoff release

If the building is equipped with a gas range it should be used for the initial system purge. The piping layout will dictate how much of the piping system is purged from this location. When purging at the open burner hold a continuous flame up to the burner. Use a lighted taper or torch that will enable you to keep your hand a safe distance from the burner ports. The air/gas mixture is flared off at the burner until a stable flame is established.

For the other gas appliances, without open burners, a hoses purge assembly can be connected as close as possible to appliance. The drip pocket or control valve inlet pressure port are two convenient locations that may be used. One of these may have already been used to check the appliance inlet pressure.

The following hose purging assembly method may only be used under the following conditions:

- The appliance must be located in a well-ventilated area
- All potential sources of ignition must be removed or shutoff
- Maximum pipe size of NPS 1 or tube size of NTS  $\frac{3}{4}$
- Longest run of piping or tubing is 100 ft (30 m)
- Maximum system pressure is 2 psig
- Maximum pressure at the purge point is 11 in. w.c.

If the gas piping system does not meet any of these conditions then it must be purged to outdoors as per the gas code or good engineering practice.

The purging hose assembly must have an automatic shutoff release valve to ensure the gas outlet is monitored continuously and is not able to be left in the open position (Figure 7).

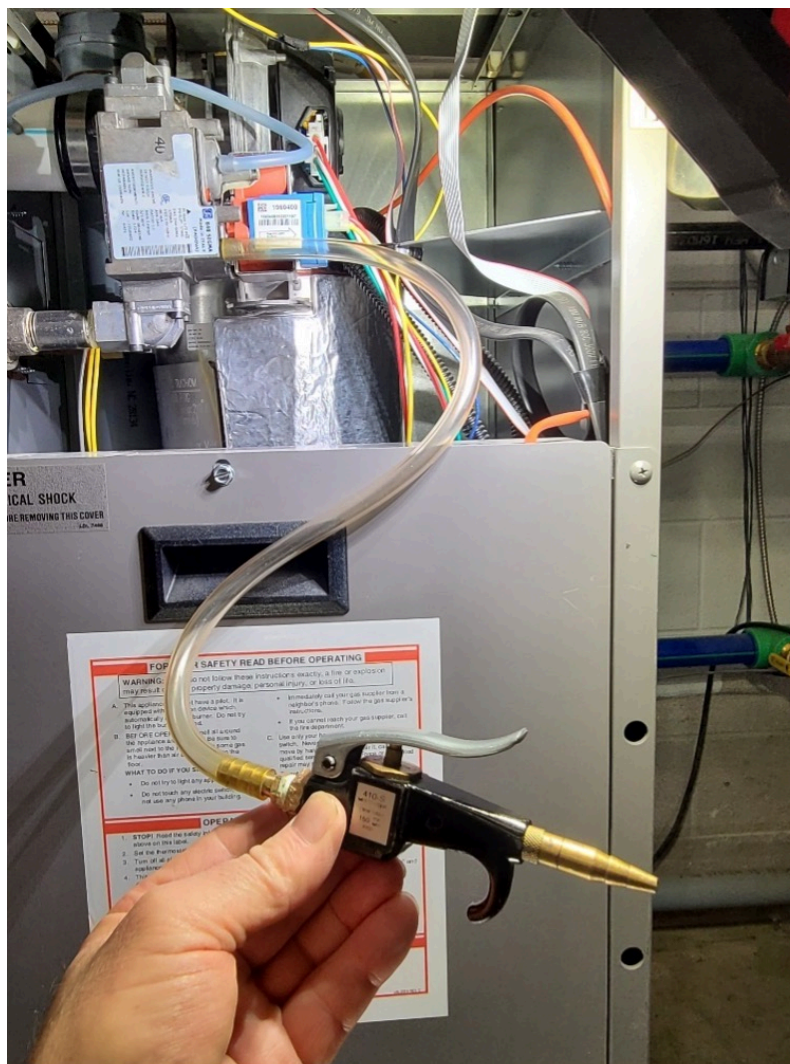

Figure 7. Purge hose with automatic shutoff release valve

Use the following steps to complete the purging procedure:

- Ensure the appliance manual shut-off valve is closed.
- Connect the purging assembly at the appliance inlet.
- Verify the appliance automatic control valve is closed.
- Open the appliance manual shut-off valve.
- Leak (bubble) test all of the purge assembly connections.
- Use the gas code appendix or engineering tables to determine the approximate purge time. Ensure that the purge does not exceed 100 seconds.
- Begin purging by depressing the spring-loaded automatic shut-off valve lever in a continuous and uninterrupted manner.  
*Caution: the automatic shut-off valve must not be fixed in the open position.*
- Release the purge valve when you detect a smell of gas from the purge valve outlet or when the approximate purge time has elapsed.
- Close the appliance manual shut-off valve and disconnect the purging assemble and fittings.
- Reassemble the piping or reinstall control valve plug
- Open the appliance manual shut-off valve and soap test the affected joints

There will still be a small amount of air in the gas valve train that will need to be purged during the appliance start-up procedure, but this should be expelled immediately into the combustion chamber and still enable the gas appliance to light quickly and smoothly.

## Pipeline repair purging

Whenever an existing gas pipeline needs to be removed for repair, alteration or abandonment the same code purge procedures are applied to purge the combustible gas from the piping.



Now complete Self-Test 2 and check your answers.

## Self-Test 2

Self-Test 2



*An interactive H5P element has been excluded from this version of the text. You can view it online here:*  
<https://opentextbc.ca/plumbing4b/?p=46#h5p-8>

## Media Attributions

- Figure 6. “Checking appliance control valve inlet pressure” by Rod Lidstone is licensed under a [CC BY-NC-SA licence](#).
- Figure 7. “Purge hose with automatic shutoff release valve” by Rod Lidstone is licensed under a [CC BY-NC-SA licence](#).



# Competency B4: Install Air Supply Systems for Fuel Gas Appliances

The efficient and safe operation of gas-fired appliances relies on an adequate supply of air. In this competency you will learn how air supply systems are designed and installed to deliver the air supply requirements of gas fired appliances.

## Learning Objectives

After completing the learning tasks in this competency, you will be able to:

- Describe the different methods of providing gas appliance air supply
- Interpret code requirements for gas appliance air supply
- Describe the installation of passive air supply systems

The following learning outcomes, from previous studies, should be reviewed before proceeding with this learning module:

- Define the four major subsystems that make up the building as a system
- Define the building envelope
- Define different building air requirements including:
  - Ventilation air
  - Make-up air
- Air supply for fuel burning appliances
- Define the different air requirements for gas fired appliances
- Define gas appliance draft terminology including:
  - Natural draft
  - Mechanical draft
  - Backdrafting
- Describe gas appliance categories as defined in the gas code



## Learning Task 1

### Describe The Methods of Providing Gas Appliance Air Supply

Air consumed by any fuel burning appliances must be considered in order to maintain a balanced building. The efficient and safe operation of gas-fired appliances relies on an adequate supply of air over and above that required for building ventilation or make-up air. For all gas appliances, the source environment of the air supply is critical. Combustion air must be free of corrosive chemicals and excessive local atmospheric pressure fluctuations.

There are two common methods of delivering the air supply requirement to a gas appliance:

- direct vent systems
- room air systems (non-direct vent)

### Direct vent systems

For a direct vent system all of the air for the appliance is taken directly from the outside as well as the flue gas is discharge to outdoors. Therefore, direct vent appliance will have no effect on the air balance of the building. Direct vent systems typically have two piping options either concentric coaxial pipe or twin pipe (Figure 1).

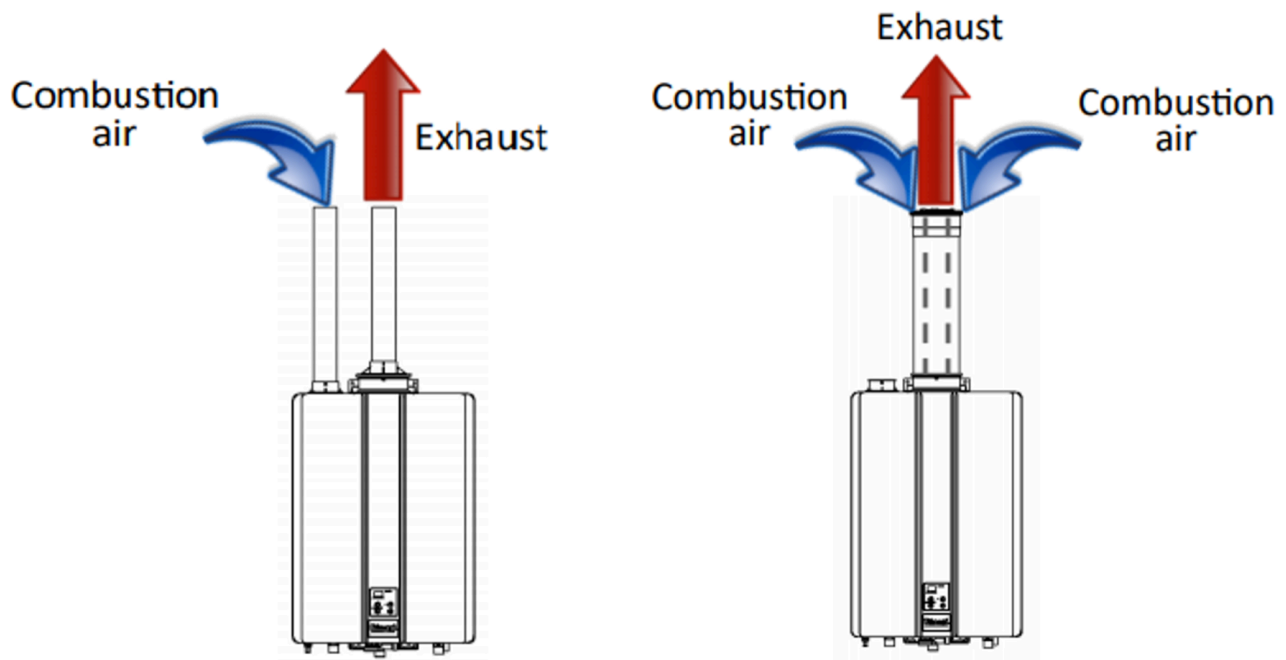
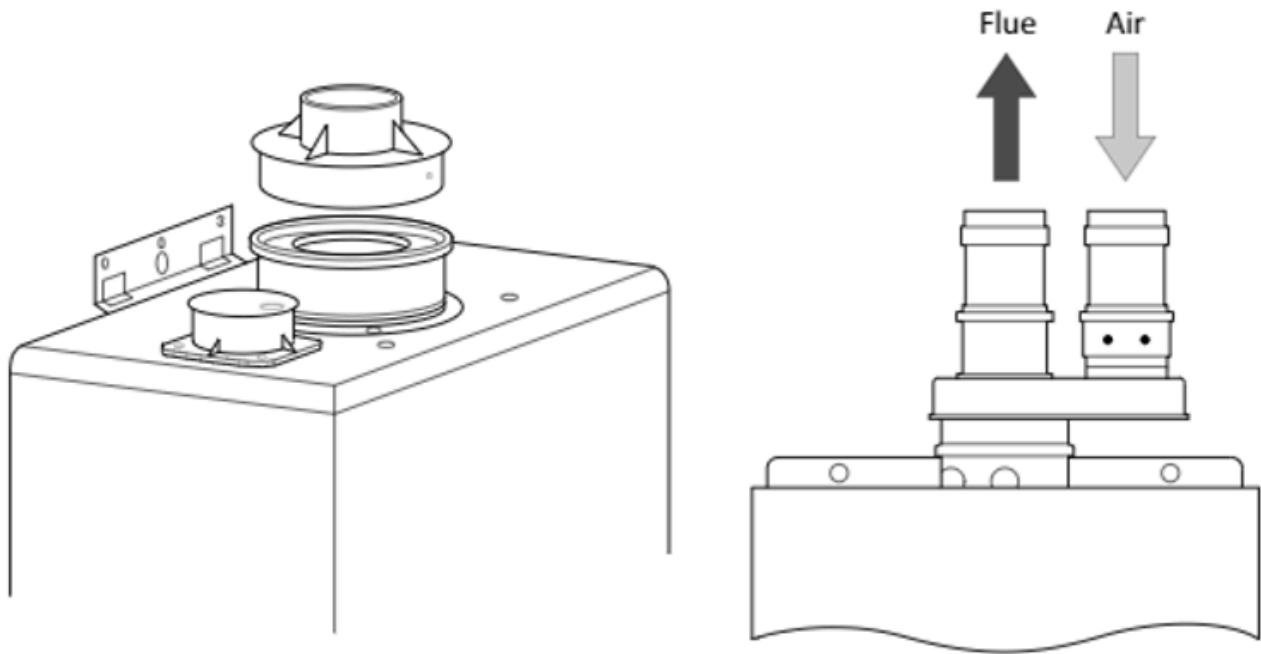

Figure 1. Direct vent appliances

There are a variety of materials that are used for the venting and air supply piping on direct vent

appliances. Some direct vent appliances are designed to use either concentric or twin pipe direct vent options, with the use of the manufacture supplied starter adapter (Figure 2).



*Figure 2. Direct vent starter adapters*

Direct vent appliances air supply and exhaust piping system must be sized and installed according to the manufacturer literature and therefore, are not sized by the requirements of the B149.1 Gas code.

Regardless of the category type, if an appliance utilizes indoor combustion air it is not considered a direct vent appliance. For example some direct vent appliances may also be installed as room air dependent systems (Figure 3), in this case the room air supply needs to conform to the manufacturer's instructions as well as to the gas code.

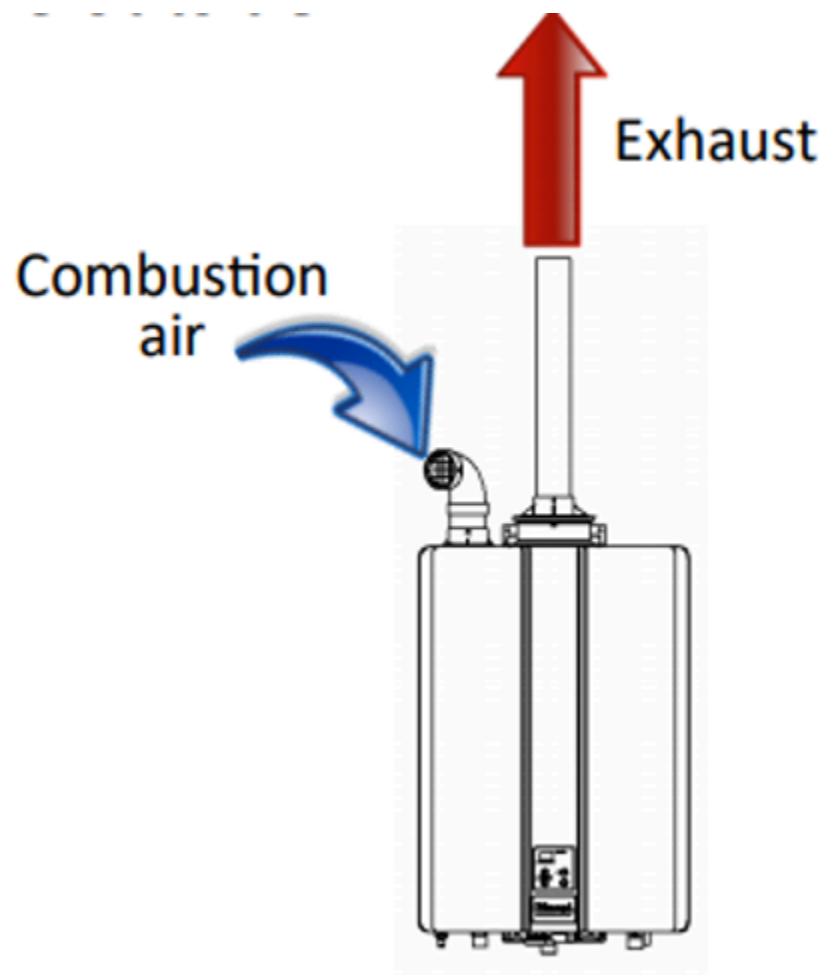

*Figure 3. Room air dependent direct vent appliance*

## Room air systems

Non-direct vent gas appliances draw all of their air supply requirements from the internal room air. The amount of air required will depend on the type of appliance(s) in the room. If an appliance is a natural draft appliance designed to operate with a draft control device, it will require a larger volume of air supply than equipment designed to operate with no draft control device, based on the dilution air requirement (Figure 4).

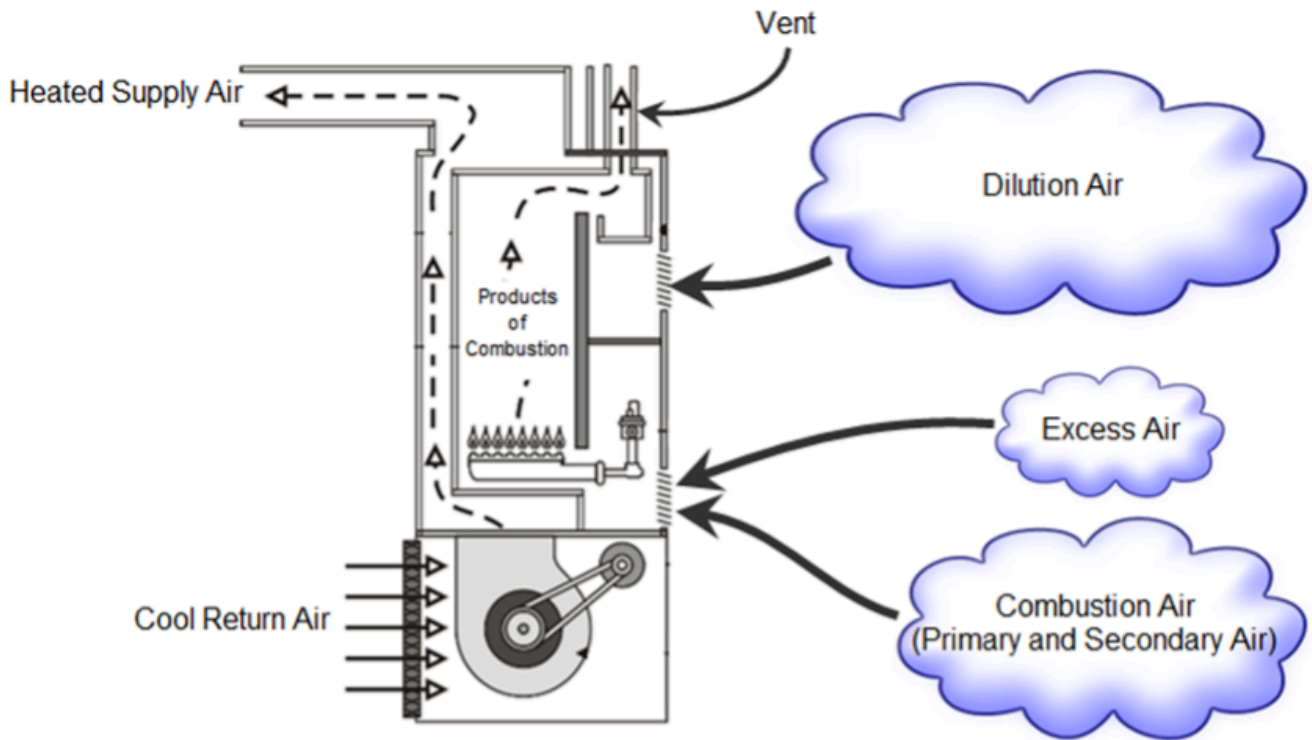

Figure 4. Room air requirements

If adequate outside air is not supplied to the room it will create a negative pressure in the room which will affect the safe operation of the appliances. Depressurization in a building with spillage-susceptible appliances must be limited to  $-0.02$  inch w.c. ( $-5$  Pa). The outside air is normally brought close to the gas appliance burners via a duct (Figure 5), but a hole in the wall may be used in some instances.

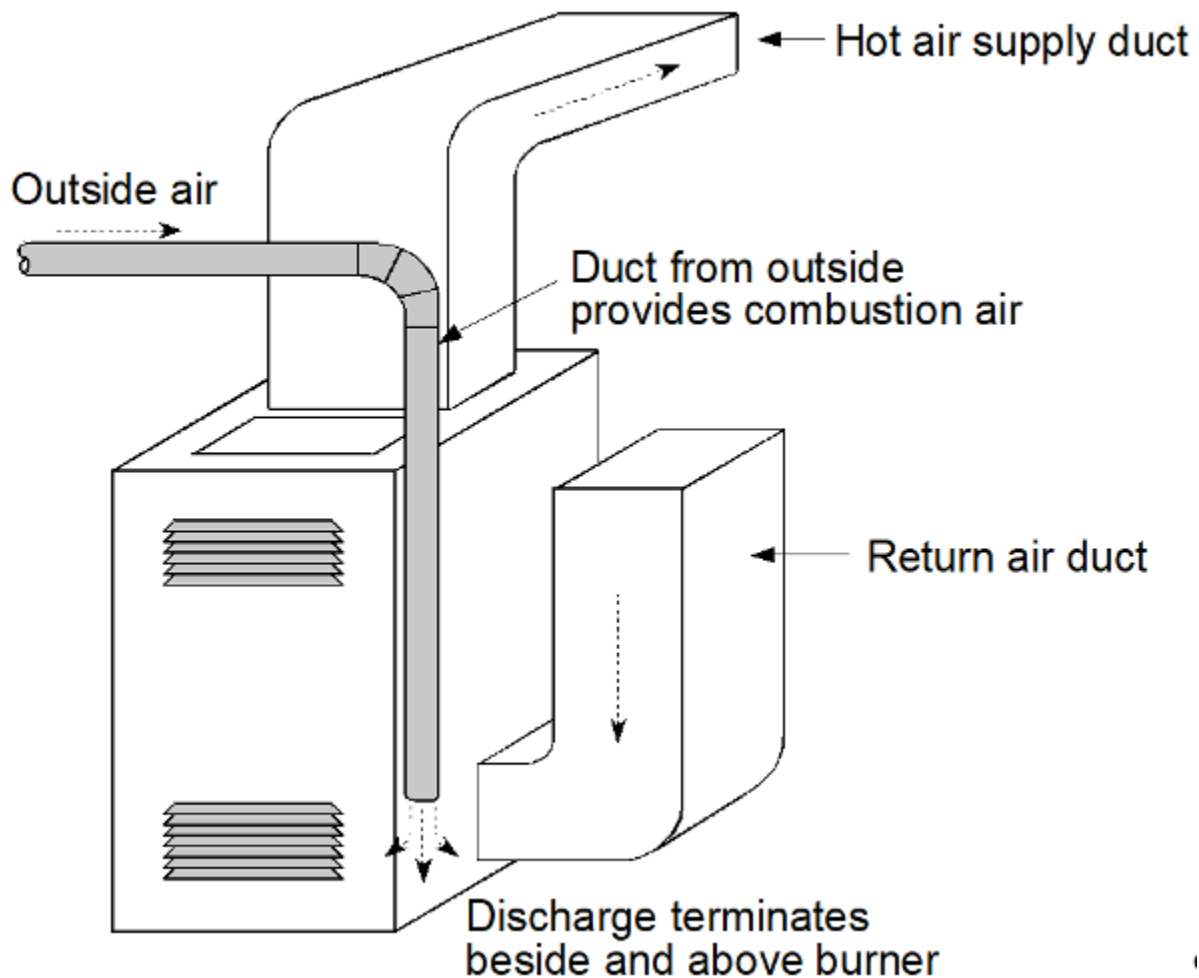

Figure 5. Ducted gas appliance air supply

The size and location of the duct will be determined by a number of factors including:

- the input of the appliances (Btu/h)
- type of appliances (draft control device or not)
- building construction

Some loosely constructed buildings with adequate air infiltration and large enough volume, such as a warehouse, may not require an outside opening. In these cases, as the air supply can be provided directly from within the structure with no need for ducts or openings. Even in these instances, the indoor air supply may not be suitable if excessive dust or a corrosive atmospheric condition exists.

These methods of using a duct or opening to outside could be referred to as passive air supply compared to a mechanical air supply such as a fan. If a mechanical air supply is used it must be properly sized and interlocked with the appliances to shut-off the gas in the event of an air supply failure. This type of system will require that the gas be reactivated by a manual reset control so that corrective measures are taken by the service technician before the appliance is operated again.



Now complete Self-Test 1 and check your answers.

## Self-Test 1

### Self-Test 1



An interactive H5P element has been excluded from this version of the text. You can view it online here:  
<https://opentextbc.ca/plumbing4b/?p=49#h5p-9>

## Media Attributions

- Figure 1. “[Direct vent appliances](#)” from Rinnai is used for educational purposes under the basis of fair dealing.
- Figure 2. “Direct vent starter adapters” – The source for this image is unknown. It is being used for non-commercial, educational purposes. To receive credit for this image, please reach out to the publisher.
- Figure 3. “[Room air dependant direct vent appliance](#)” from Rinnai is used for educational purposes under the basis of fair dealing.
- Figure 4. “Room air requirements” – The source for this image is unknown. It is being used for non-commercial, educational purposes. To receive credit for this image, please reach out to the publisher.
- Figure 5. “Ducted gas appliance air supply” – The source for this image is unknown. It is being used for non-commercial, educational purposes. To receive credit for this image, please reach out to the publisher.

---

## Learning Task 2

### Code Requirements For Gas Appliance Air Supply

In this learning task, we will examine the air supply gas code requirements in the gas code. These interpretations are not legal; the clauses contained in the code must be referenced as to the exact legal meaning.

For safe and efficient operation of gas appliances, the Gas Codes require that you supply enough air for combustion, venting, and ventilation of the mechanical room. The Gas Code will specify various methods of meeting the air requirements. You must clearly understand Code requirements before you can determine the correct sizes of air supply ducts or openings.

Clauses 8.2 to 8.7 of the CSA B149.1 gas code, identify the requirements for the installation and sizing of passive combustion air supply openings and ducts. As previously mentioned the gas code requirements for venting and air supply do not apply to direct vent appliances as these have their own independent air supply and exhaust systems which are sized according to the manufactures' literature.

When determining the passive air supply requirements for gas appliances, the B149.1 Gas code separates installations into two categories:

- Low Volume Installations – installations up to and including 400 000 Btuh (120 kW)
- High Volume Installations – installations over 400 000 Btuh (120 kW).

The Gas Code also allows for air to be supplied mechanically. This usually requires a ducted system with some type of fan to force movement of the air supply. The National Code is not specific about forced air flow design other than to say “sufficient air flow shall be demonstrated”. Additionally, in British Columbia there is a Variation to the National Code that requires the fan supply at least 30 ft<sup>3</sup> of outside air for each 1 000 Btuh of gas supplied to the burners, when the appliances served have draft control devices

### Passive air supply requirements for low volume installations

The air supply requirements for gas appliances with a total input of up to and including 400 000 Btu/h or 120 kW. are determined from clauses 8.2 and 8.3. The tables used within clause 8.2 will indicate the minimum size of the required air supply in relation to the combined input of the gas appliances.

As you read the code requirements of Clause 8.2 you will be required to identify key points related to the type of equipment and the structure of the building housing it. These include:

- appliance type and location
- building construction
- appliance type of draft control.

## **Appliance type and location**

The Code states that clause 8.2 applies to the air supply for central heating furnaces, boilers, and hot water heaters. However, clause 8.1.5 also indicates, that the same care and attention must be taken to ensure that all gas-burning appliances and equipment have a clean and adequate air supply.

Any interference with the air supply is prohibited. For example, the required air supply values in the code are only the required air supply for the gas appliances and do not account for any other air being consumed or removed from the space around the appliances or equipment. When there is more than one gas appliance in the same room the air supply will be ducted to the appliance having the largest input.

## **Building construction**

The current construction methods used in residential and commercial buildings will typically create a tight building envelope. Code clause 8.2.1 gives two methods of determining whether the building envelope is classified as tight. For sizing examples you may also see tight construction described as, a building that complies with 8.2.1. Another descriptor may be R-2 000. If you are in doubt it is always safest to assume the building envelop is tight, (complies to 8.2.1), and the air supply will be sized according to clause 8.2.2.

If a building is not airtight, described as loose, or does not comply to 8.2.1, and the volume is large enough, the air supply may be provided directly from within the structure with no need for ducts or openings to the outside. If the volume is not large enough then an outdoor air supply will be needed just as it was for a tight structure. Consult tables 8.3 and 8.4 in CSA B149.1.

## **Appliance draft control**

One you have established whether or not the appliance(s) are located in a tight or loose structure, you will need to select a sizing table. There are two tables, for each of the building types. The table selection is determined by whether or not the appliance(s) are equipped with a draft control device.

Appliance(s) equipped with draft control devices (draft hood, draft diverter, or barometric draft regulator) require both combustion and dilution air and will be sized from either Table 8.1 (tight construction) or Table 8.3 (loose construction).

Appliance(s) equipped without draft control devices will have a lesser air supply requirement, as they do not require dilution air, will be sized from either Table 8.2 (tight construction) or Table 8.4 (loose construction).

Often equipment with draft control devices and equipment without draft control devices are installed together and take air supply from the same source. In such cases, the required size of air supply opening is based on the greater of either the size required by Table 8.1 or 8.3 using the total input of only those appliances having draft control devices or the size required by Table 8.2 or 8.4 using the total input of all appliances. To help understand this, the steps would be as follows:

1. Identify the type of structure and the tables to use.

2. Total the input of all equipment with draft control devices.
3. Determine the required free area from either Table 8.1 or Table 8.3.
4. Total the input of **all** equipment with and without draft control devices.
5. Determine the required free area from either Table 8.2 or Table 8.4.
6. Choose the larger of the areas indicated for steps 3 or 5

### Low volume sizing examples

Work through the following examples, referencing and confirming each step with the Gas Code

#### Example 1

What would be the size of an air supply duct serving an 80 MBH hot water boiler and a 50 MBH hot water tank? Both appliances have draft hoods and the building complies with code clause 8.2.1.

#### **Solution:**

1. Installation totals 130 MBH (80 MBH + 50 MBH) and therefore would be classified as low volume and Code clause 8.2 applies.
2. Is the structure tight or loose?

Since this example problem complies with 8.2.1, it would be considered a tight structure therefore 8.2.2 is the code clause that specifies the sizing method to be used for low volume airtight installations.

3. Do the appliances have draft control or not?

Both appliances in this example have draft control devices and therefore the air supply would be sized from Table 8.1. When using Table 8.1, take the total input of the appliances and refer to the left hand column of the table. Select an input equal to or greater than the input of our appliances (we would rather give it more air than not enough air), in this case 150 MBH. The center column of the table lists the minimum unobstructed (or free) area of the air supply. For this example, the minimum free area required for the air supply duct would be 22 in.<sup>2</sup>

The right hand column is the *minimum acceptable* round duct size, therefore for an input of 150 MBH, the minimum acceptable round duct size would be 5 inches in diameter

*It is worth noting that the round duct column is not an exact conversion from the required free area column. Each acceptable approximate round duct size with covers a range of minimum free area rows.*

## Example 2

What would be the minimum required free area of a rectangular air supply duct serving two 100 MBH fan-assisted boilers that are not equipped with draft control devices, if the building is considered tight?

**Solution:**

1. Installation totals 200 MBH (100 MBH + 100 MBH) and therefore would be classified as low volume and Code clause 8.2 applies.
2. Is the structure tight or loose?

The building is considered an airtight structure therefore 8.2.2 is the code clause that specifies the sizing method to be used for low volume airtight installations.

3. Do the appliances have draft control or not?

Both appliances in this example do not have draft control devices and therefore the air supply would be sized from Table 8.2. Since the total input of the appliances in this example is 200 MBH, the air supply duct must be sized using the 200 MBH row. The center column lists the minimum required free area of the air supply duct. For 200 MBH the minimum required free area for our rectangular duct would be 14 in.<sup>2</sup>

*Clause 8.3.2 stipulates that a square or a rectangular duct may be used as an air supply, but it cannot have a dimension of less than 3 inches due to concerns over flow resistance. Therefore the free area can never be less than 9 in.<sup>2</sup> when using rectangular duct.*

## Example 3

A building that complies with code clause 8.2.1, is to contain one 75 MBH gas-fired appliance with a draft hood and one 50 MBH appliance without a draft control device. What would be the minimum required free area of a rectangular air supply duct to these appliances?

**Solution:**

1. Installation totals 125 MBH (50 MBH + 75 MBH) and therefore would be classified as low volume and Code clause 8.2 applies.
2. Is the structure tight or loose?

The building is considered an airtight structure therefore 8.2.2 is the code clause that specifies the sizing method to be used for low volume airtight installations.

3. Do the appliances have draft control or not?

This installation contains both types of appliances, one appliance with draft control and one without. Code clause 8.2.2 requires that we must take the appliance with draft control and size the air supply from Table 8.1.

Then we would take the total input of all the appliances added together and size the air supply from Table 8.2. Whichever method produces the largest size, would be the size of our air supply.

When the 75 MBH appliance with the draft hood is sized from Table 8.1 the minimum opening is 11 in.<sup>2</sup>.

When the appliances are added together (125 MBH) and sized from Table 8.2, the free area air supply is 9 in.<sup>2</sup>. The larger size must be used; therefore, the air supply for this example problem would be 11 in.<sup>2</sup>.

#### Example 4

What would be the minimum required free area of a rectangular air supply duct serving on 100 MBH appliance with draft hood located in a large loosely constructed warehouse with a volume of 6 500 ft<sup>3</sup>?

#### **Solution:**

1. Installation totals 100 MBH and therefore would be classified as low volume and Code clause 8.2 applies.
2. Is the structure tight or loose?

The building is considered a loose structure therefore 8.2.5 is the code clause that specifies the sizing method to be used for low volume loose building installations.

In order to use Tables 8.3 or 8.4, the volume of the structure or enclosure must be known. If the building is not air tight and has a large volume to draw from the air supply from the table may indicate “0”, it means that the volume of the structure is large enough to provide the required air supply. If the volume is not large enough the table will indicate the minimum air supply duct from outdoors.

*When selecting a volume column for tables 8.3 or 8.4 if the structure volume falls between table values you must round down to the smaller table volume.*

3. Do the appliances have draft control or not?

The appliances in this example have a draft control device and therefore the air supply would be sized from Table 8.3.

With an appliance input of 100 MBH and a volume of 6 500 ft<sup>3</sup>. Table 8.3 indicates that the required free area of the outdoor air supply, at a volume of 6 000 ft<sup>3</sup>, would be 0 in.<sup>2</sup>. Therefore, the appliance will be able to draw its air supply from the unrestricted building volume.

Notice on Table 8.3 if the volume of the structure was reduced to any size less than 6 000 ft<sup>3</sup> an outside air supply of 11 in.<sup>2</sup> would be required. It is also worth noting that all of the sizes required as a result of smaller volumes on Table 8.3 are consistent with the air requirements of Table 8.1. This is also true when comparing Table 8.4 to 8.2 for appliances without draft control.

### Enclosures in a loose structure (low volume)

When a low volume installation is located within an enclosure (room) within a loose structure (building) you may be able to draw the air supply from the structure by adding openings in a wall

between the room and the building. This would enable the entire volume of the building to be used and thereby possibly avoiding the need for an outside air supply into the room. The quality of the building air must be accessed before considering this option.

The criteria explained in Clause 8.2.6 is **only** meant to be applied if the building has sufficient volume to supply the appliance(s). Therefore, the first step is to check that air supply when sized from Table 8.3 or Table 8.4 gives a table value is “0”, indicating that an outdoor air supply is not required as the building has sufficient volume. In these cases, the entire volume of the structure may be used when permanent openings are provided in accordance with Clause 8.2.6 a) and b) (Figure 6).

If you choose to not draw the air supply from the building, then the room will require an appropriately sized outdoor air supply.

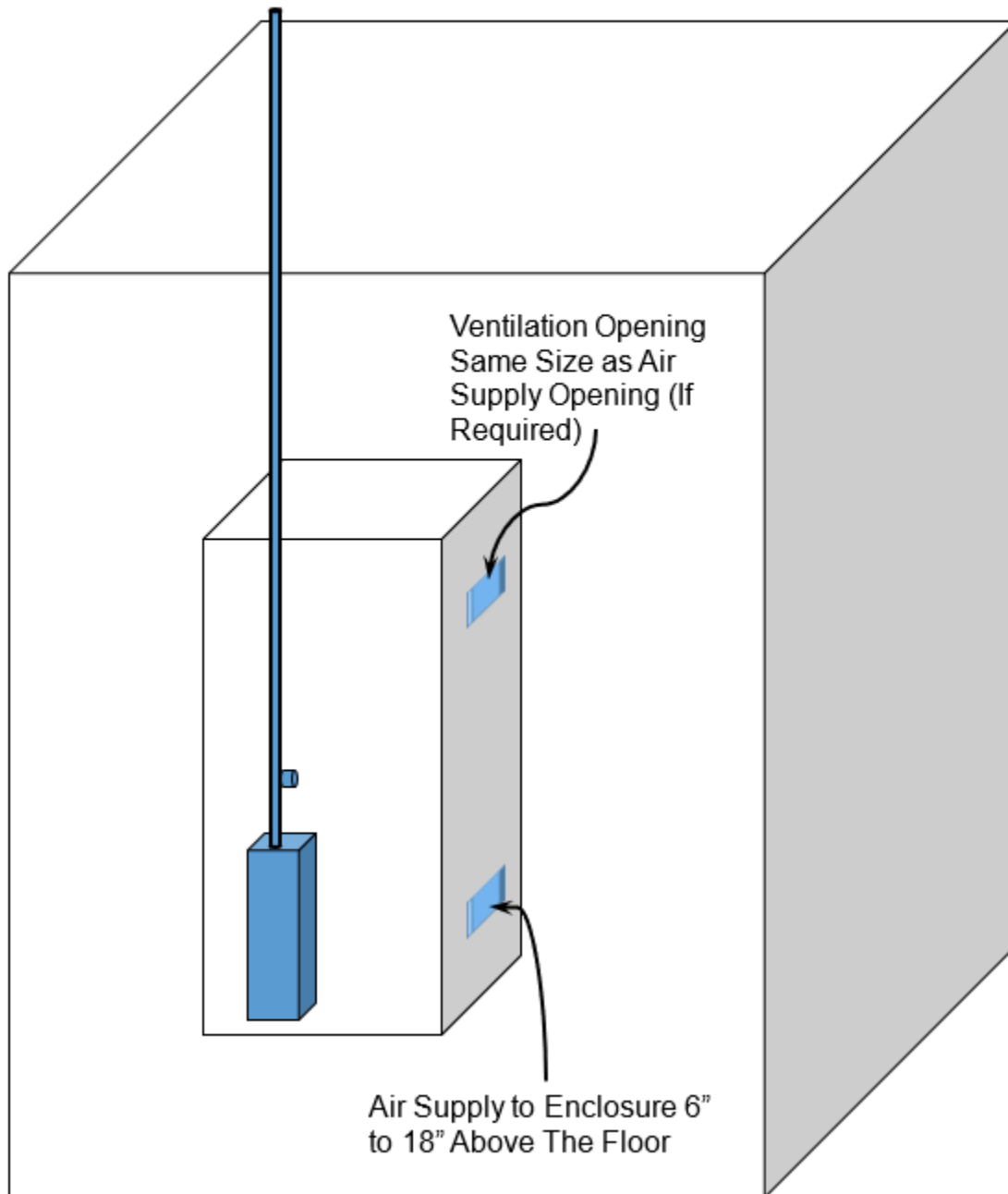

Figure 6. Enclosure within a loose structure

#### Example 5

A mechanical room is located within a warehouse of loose construction. The mechanical room contains a draft hood equipped boiler with an input of 250 MBH. The dimensions of the mechanical room are 15 ft × 10 ft × 10 ft (1 500 ft<sup>3</sup>), and the dimensions of the warehouse are 50 ft × 40 ft × 10 ft (20 000 ft<sup>3</sup>). Size the required air supply opening(s) for this installation?

**Solution:**

1. Installation totals 250 MBH and therefore would be classified as low volume and Code clause 8.2 applies.
2. The building is considered a loose structure therefore 8.2.5 is the code clause that specifies the sizing method to be used for low volume loose building installations.
3. The appliance in this example has a draft control device and therefore the air supply would be sized from Table 8.3.

The appliance has a rated input of 250 MBH and is equipped with a draft control device. The volume of the enclosure is only 1 500 ft<sup>3</sup> using this volume table 8.3 indicates an **outdoor** air supply of 36 in.<sup>2</sup> is required

Alternately if we were able to use the volume of the full structure (20 000 ft<sup>3</sup>), Table 8.3 indicates a value of “0”, which means the volume of the structure is sufficient to supply the appliance.

4. Code clause 8.2.6 will allow the use of the structure’s volume provided that a permanent opening based on 1 in.<sup>2</sup> of free area for every 1 000 Btu’s of input is located between 6 inches and 18 inches above the floor. In this case having an input of 250 000 Btu’s, we would require a 250 in.<sup>2</sup> air supply opening.

*Code clause 8.2.6 also indicates that if any of the appliances located in the enclosure have a draft control device, then a ventilation opening is also required and shall be the same size as the air supply opening. The ventilation opening must be located as high as possible in the enclosure to ensure that warm air will exit from the space.*

### Single water heater air supply

Water heaters seldom operate as continuously as furnaces or boilers. Therefore, the Gas Code stipulate that if a single non-direct vent water heater of 50 MBH or less is installed, an outdoor air supply is not required. This exception only applies if there are no other gas appliances that required an air supply, in which case the load of the water heater must be included in the sizing of the air supply of all appliance in that area.

If the water heater is contained in an enclosure, permanent opening(s) must be provided between the enclosure and the structure. These opening(s) would also be sized and located as described in Code Clause 8.2.6 a) and b).

### Passive air supply requirements for high volume installations

The air supply requirements for gas appliances with a total input over 400 000 Btu/h or 120 kW. are determined from clause 8.4. Do not try and mix in code requirements from earlier clauses related to low volume installations. The air requirements for high volume installations fall into two categories: ventilation air and combustion/dilution air supply.

## Ventilation air

High volume installations require ventilation of the space in which they are installed to remove excess heat or combustion products spilled at the draft hood to ventilate to the outdoors through natural convection. Clause 8.4.1 specifies the criteria for the ventilation air opening.

The ventilation air opening must be a separate building opening from the combustion air opening. It must communicate with outdoors and be located as high as practical within the mechanical room and not within 12 inches (300 mm) of the combustion air opening, this will ensure that warm air driven by buoyancy forces will exfiltrate from the space.

The size of the ventilation free area opening shall be at least 10% of the size of the air supply free area opening, but can never be less than 10 in.<sup>2</sup> (6 500 mm<sup>2</sup>) of free area. Therefore you will need to size the air supply opening first before the ventilation opening size can be determined.

## Air supply

As has already been discussed, some appliances will need proportionately more air supply than others due to their additional dilution air requirement. Therefore, just as was the case with low volume installations you will need to first identify whether or not the appliance(s) are equipped with draft control devices. Once this has been determined the appropriate air supply requirements can be selected from one of three options:

- Clause 8.4.2 where all appliances within the space have draft control devices
- Clause 8.4.3 where all appliances within the space do not have draft control devices
- Clause 8.4.4 there is a mixture of appliances with and without draft control devices within the space.

The air supply must come from the outdoors and the free area is determined by the input of the appliances within the room.

### Equipment with draft control

For appliance(s) with draft control the area of the air supply shall be at least 1 in.<sup>2</sup> for every 7 000 Btu's of input up to and including 1 000 000 Btu's, plus 1 in.<sup>2</sup> for every 14 000 Btu's in excess of 1 000 000 Btu's. For metric calculations use; 310 mm<sup>2</sup> for every kW up to and including 293 kW plus 155 mm<sup>2</sup> for every kW in excess of 293 kW).

The air supply shall be located not less than 6 in. (150 mm) or more than 18 in. (450 mm) above the mechanical room floor (Figure 7).

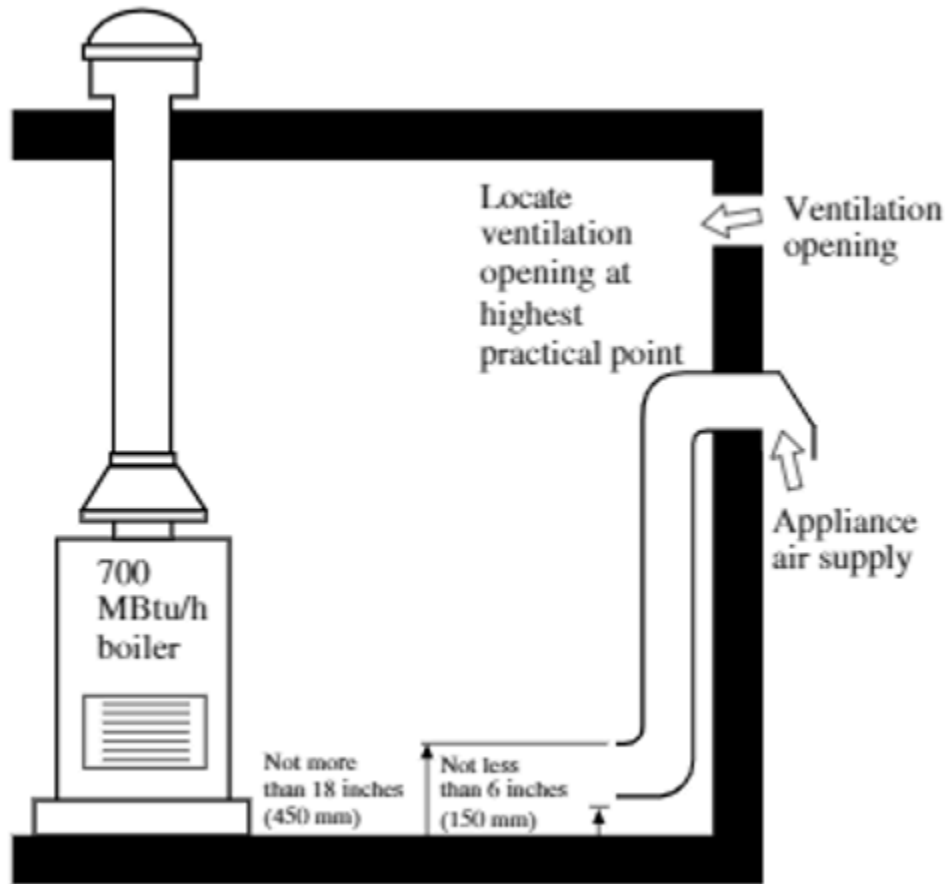

Figure 7. Air supply duct location

Example 6

A mechanical room is equipped with gas appliances that have a total input of 1 400 MBH. All of the appliances have draft control devices. Size the minimum free area for both the air supply and ventilation openings.

**Solution:**

1. The installation totals exceed 400 MBH and therefore are classified as high volume and Code clause 8.4 applies.
2. All of the appliances have draft control devices and therefore the air supply would be sized by the method described in code clause 8.4.2.

- 1 in.<sup>2</sup> for every 7 000 Btu's up to and including 1 000 000 Btu's.

$$1\ 000\ 000\ \text{Btu} \div 7\ 000 \frac{\text{Btu}}{\text{in.}^2} = 142.86\ \text{in.}^2$$

- 1 in.<sup>2</sup> for every 14 000 Btu's for anything in excess of 1 000 000 Btu's.

$$400\,000 \text{ Btu} \div 14\,000 \frac{\text{Btu}}{\text{in.}^2} = 28.57 \text{ in.}^2$$

- Therefore, the size of the air supply for this installation would be:

$$142.86 \text{ in.}^2 + 28.57 \text{ in.}^2 = 171.43 \text{ in.}^2$$

- Code clause 8.4.1 states: all ventilation openings shall be at least 10% of the size of the air supply opening but can never be less than 10 in.<sup>2</sup> (6 500 mm<sup>2</sup>).

Therefore, the size of the ventilation opening would be:

$$171.43 \text{ in.}^2 \times 10\% = 17.143 \text{ in.}^2$$

17.143 in.<sup>2</sup> is greater than the minimum allowable size of 10 in.<sup>2</sup>

### Equipment without draft control

Appliances without draft control devices require only combustion air as the venting of such appliances relies on a mechanically driven pressure difference. The size of air supply opening is, therefore, less than that required for appliances with draft control devices.

For appliance(s) without draft controls the free area of the air supply shall be 1 in.<sup>2</sup> for every 30 000 Btu's (or 70 mm<sup>2</sup> for every kW) of the total input of the power burner(s).

Since these power burners create a mechanical pressure difference through the appliance and will draw in the required combustion air, air supply openings may be located anywhere, provided that these do not interfere with the performance of the ventilation air opening(s).

#### Example 7

A mechanical room is equipped with gas appliances that have a total input of 1 400 MBH. None of the appliances have draft control devices. Size the minimum free area for both the air supply and ventilation openings.

#### **Solution:**

- The installation totals exceed 400 MBH and therefore is classified as high volume and Code clause 8.4 applies.
- All of the appliances have power burners without draft control devices and therefore the air supply would be sized by the method described in code clause 8.4.3.

- 1 in.<sup>2</sup> for every 30 000 Btu's of total input.

$$1\,400\,000 \text{ Btu} \div 30\,000 \frac{\text{Btu}}{\text{in.}^2} = 46.67 \text{ in.}^2$$

- Therefore, the size of the air supply for this installation would be:  
**46.67 in.<sup>2</sup>**

3. Code clause 8.4.1 states: that all ventilation openings shall be at least 10% of the size of the air supply opening but can never be less than 10 in.<sup>2</sup> (6 500 mm<sup>2</sup>).

$$46.67 \text{ in.}^2 \times 10\% = 4.667 \text{ in.}^2$$

Since 4.667 in.<sup>2</sup> is less than the minimum allowable size of 10 in.<sup>2</sup> the size of the ventilation air opening would be 10 in.<sup>2</sup>

### A mix of equipment with and without draft control

When appliances with and without draft control devices are installed, clause 8.4.4 requires that the air supply must be calculated separately for the applicable appliance type. In other words, calculate the requirements for all draft control equipped equipment as per Clause 8.4.2 and calculate the requirements for all of the power burners as per Clause 8.4.3. The cross-sectional area for the two types of appliances can be provided using either separate openings or a single opening with the total area of both requirements. If a single opening is used it must be located as per 8.4.2 to ensure it will properly serve the appliances with draft controls.

Once again, this air supply requirement(s) must be in addition to the air opening for ventilation air.

#### Example 8

Calculate the free area of the air supply and ventilation openings required for the following installation:

A structure has a mechanical room into which air must be ducted from outdoors. It contains the following appliances:

- Three boilers rated at 400 000 Btuh each equipped with a barometric damper.
- Two duct heaters equipped with power burners that are rated at 400 000 Btuh each.
- Two storage type hot water tanks rated at 300 000 Btuh each. Both tanks are equipped with draft hoods.

*Combine into single air supply and ventilation openings with the total area of both requirements.*

#### **Solution:**

1. The installation totals exceed 400 MBH and therefore are classified as high volume and Code clause 8.4 applies.
2. Some appliances have draft control and some do not, therefore the air supply would be sized by the method described in code clause 8.4.4.

#### **Total input of the appliances with draft control:**

(Boilers) 1 200 000 Btuh + (Hot water tanks) 600 000 Btuh = 1 800 000 Btuh

- Air supply sized by the method described in code clause 8.4.2:

$$1\,000\,000 \text{ Btuh} \div 7\,000 \frac{\text{Btuh}}{\text{in.}^2} = 142.857 \text{ in.}^2$$

$$800\,000 \text{ Btuh} \div 14\,000 \frac{\text{Btuh}}{\text{in.}^2} = 57.143 \text{ in.}^2$$

- The area of the air supply required for the appliances with draft control would be:  
 $142.857 \text{ in.}^2 + 57.143 \text{ in.}^2 = 200 \text{ in.}^2$

**Total input of the appliances without draft control devices:**

(Duct heaters) 800 000 Btuh

- Air supply sized by the method described in code clause 8.4.3:

$$800\,000 \text{ Btuh} \div 30\,000 \frac{\text{Btuh}}{\text{in.}^2} = 27 \text{ in.}^2$$

- The area of the air supply required for the appliances without draft control would be:  
 $27 \text{ in.}^2$

**The total free area of the single air supply opening required for this installation would be:**

$$200 \text{ in.}^2 \text{ (with draft control)} + 27 \text{ in.}^2 \text{ (without draft control)} = 227 \text{ in.}^2$$

3. The single ventilation opening required by Code clause 8.4.1 would be:

$$227 \text{ in.}^2 \times 10\% = 22.7 \text{ in.}^2$$

22.7 in.<sup>2</sup> is greater than the minimum allowable size of 10 in.<sup>2</sup>.

Figure 8 summarizes the clauses and table that relate to sizing air supply openings for gas appliances.

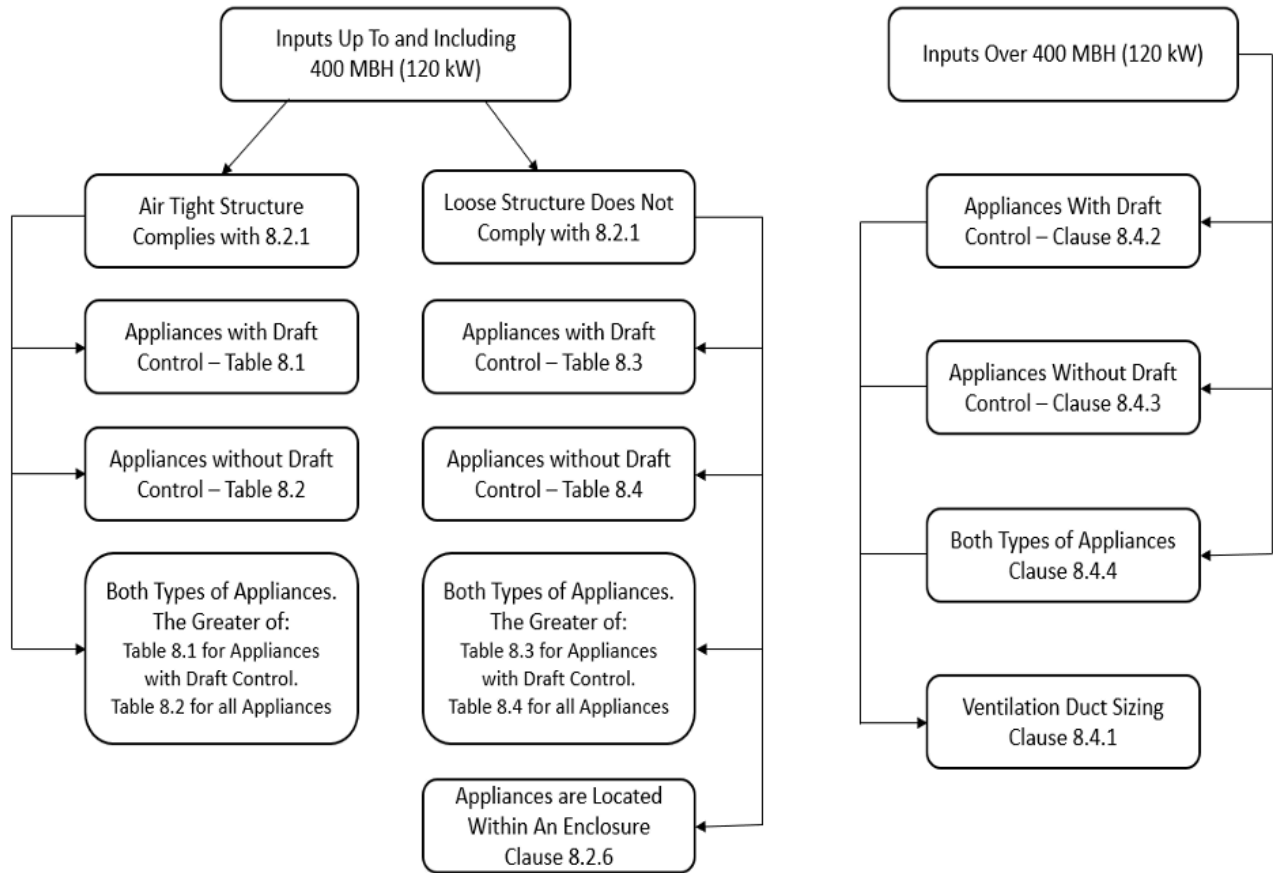

Figure 8. Air supply flow chart [\[Image Description\]](#)

## Grilles, louvres, screens and dampers

The air supply inlet openings from outdoors must protect against the entry of wind and rain. This will typically require the addition of grilles, louvers, or dampers. Grilles and louvers create a resistance to air flow; therefore, the grille area will need to be larger than the required free area from the code. The area of the grilles, bars, or slats is subtracted from the area of the opening to attain the free area of the grille.

To help you determine the free area, manufacturers provide charts that list grille efficiencies and/or their respective free areas. Common louver free areas range from 35% to 60% of the wall opening which means they have 65% to 40% obstructed area respectively. For example, the louvered grille shown in Figure 9 measures 300 mm × 400 mm giving it an opening area of 120 000 mm<sup>2</sup>. If the grille has an efficiency of 65%, the free area of the opening with this grille installed will be 120 000 × 65% = 78 000 mm<sup>2</sup> (121 in.<sup>2</sup>).



*Figure 9. Metal louvered grille*

In reality though we would typically first know the required free area from our code regulations. Are we would need to calculate what size of louvered opening we would need. In this case the grille area(size) can be calculated by:

Required free area of the air supply  $\div$  by the grille efficiency = required grille area

For example: If you were using code table 8.1 with an appliance input of 250 MBH the required free area would be 36 in.<sup>2</sup> of free area. If the grille has an efficiency of 60% then

$$36 \text{ in.}^2 \div 60\% = 60 \text{ in.}^2 \text{ minimum grille area}$$

For this installation you could use a reducing transition fitting (Figure 10) at the grille connection, or an oversized duct, with the same size as the grille opening.

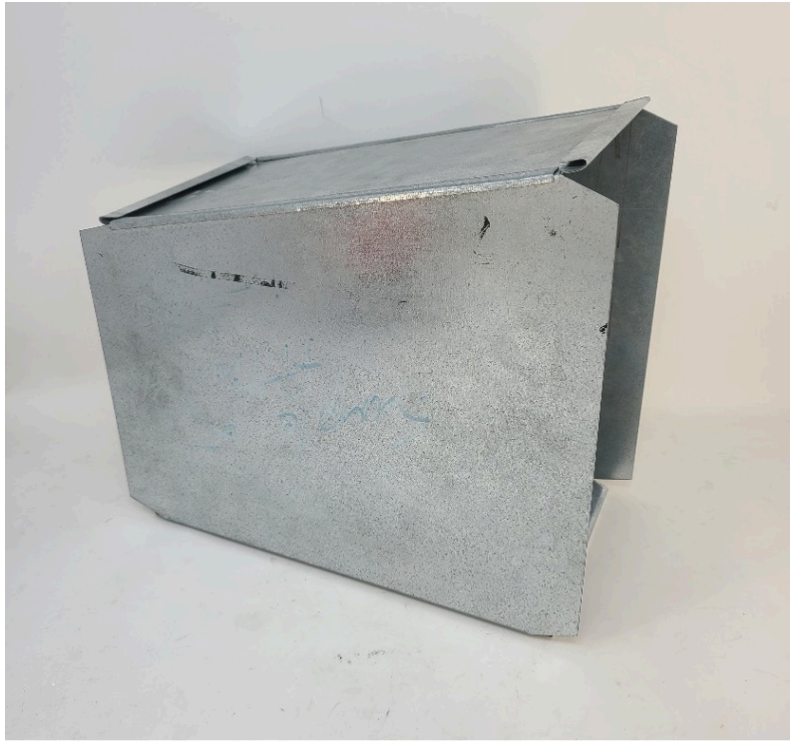

*Figure 10. Sheet metal rectangular reducer*

## Grille design

Part 6 of the National Building Code of Canada requires that any duct or opening leading from the inside to the outside of a building or enclosure must be fitted with corrosion-resistant screens. The Gas code requires that the openings in a fixed louver, grille or screen cannot be smaller than  $\frac{1}{4}$  inch (6 mm) so that small impurities in the air will not block the openings and restrict air flow.

Automatic dampers and louvers are permitted provided that they are interlocked with the appliance(s) burner so that it cannot operate unless they are fully open to ensure proper air supply. Manually operated dampers and manually adjustable louvers are not permitted as these may be accidentally closed.



Now complete Self-Test 2 and check your answers.

## Self-Test 2

### Self-Test 2



An interactive H5P element has been excluded from this version of the text. You can view it online here: <https://opentextbc.ca/plumbing4b/?p=51#h5p-10>

## Media Attributions

- Figure 6. “Enclosure within a loose structure” – The source for this image is unknown. It is being used for non-commercial, educational purposes. To receive credit for this image, please reach out to the publisher.
- Figure 7. “Air supply duct location” by Camosun College is licensed under a [CC BY-NC-SA licence](#).
- Figure 8. “Air supply flow chart” by Camosun College is licensed under a [CC BY-NC-SA licence](#).
- Figure 9. “Metal louvered grille” by Camosun College is licensed under a [CC BY-NC-SA licence](#).
- Figure 10. “Sheet metal rectangular reducer” by Camosun College is licensed under a [CC BY-NC-SA licence](#).

## Image Descriptions

### Figure 8. “Air supply flow chart” image description:

Inputs Up To and Including 400 MBH (120 kW)

- Air Tight Structure Complies with 8.2.1
- Appliances with Draft Control – Table 8.1
- Appliances without Draft Control – Table 8.2
- Both Types of Appliances. The Greater of: Table 8.1 for appliances with Draft Control. Table 8.2 for all Appliances.

174 Competency B4: Install Air Supply Systems for Fuel Gas Appliances

- Loose Structure Does Not Comply with 8.2.1
- Appliances with Draft Control – Table 8.3
- Appliances without Draft Control – Table 8.4
- Both Types of Appliances with Draft Control. Table 8.4 for all Appliances
- Appliances are Located Within An Enclosure – Clause 8.2.6

Inputs over 400 MBH (120 kW)

- Appliances with Draft Control – Clause 8.4.2
- Appliances Without Draft Control – Clause 8.4.3
- Both Types of Appliances Clause 8.4.4
- Ventilation Duct Sizing Clause 8.4.1 [\[Return to Figure 8\]](#)

---

## Learning Task 3

### Describe The Installation of Passive Air Supply Systems

As the qualified piping tradesperson you are ultimately responsible for all aspects of the installation required to ensure the safe operation of the gas appliance. Depending on the type of building, the ductwork for the air supply and ventilation air will most often be performed by a qualified Sheet Metal Tradesperson working under your installation permit.

#### Low volume air supply ducting

The passive air supply inside termination must be located within 2 ft (600 mm) horizontally and not more than 1 ft (300 mm) above, the burner level of the gas appliance (Figure 11). If there is more than one gas appliance in the area, the air supply will be located at the one with the largest input. This ensures that the air supply is dedicated to the appliance(s) served and will not be influenced by other equipment in the structure that also needs outside air.

For low volume installations the inlet opening from outside must be at least 24 in. (600 mm) between the bottom of the intake grill and the finished grade. This height is necessary to prevent air flow obstruction by snow or other materials. This height requirement is a variation for the Province of BC, as the National Code stipulates a 12 in. minimum.

The air supply will be provided by a duct, unless a wall opening can be located such that it is close enough to meet the termination location requirements.

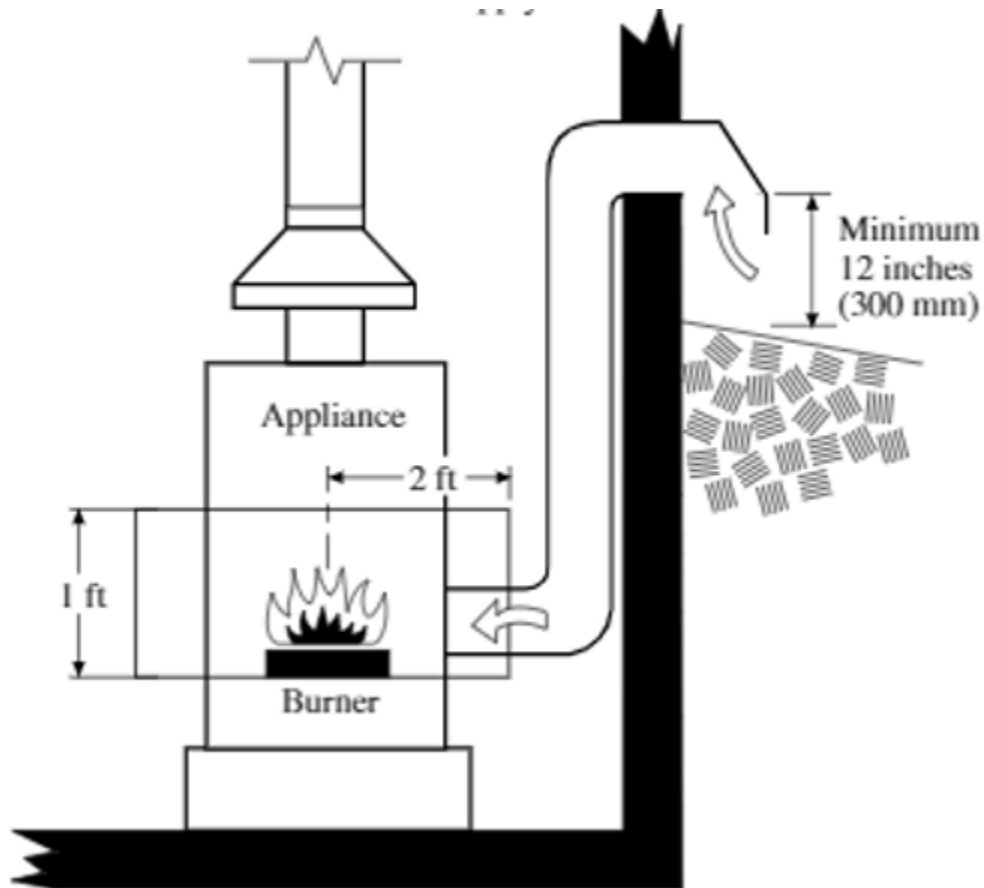

Figure 11. Passive air supply terminations

Make sure that the air supply does not come from an area that contains air borne contaminants such as swimming pools, vehicle exhaust fumes, or laundry facilities. Additionally the Gas Code states that the air supply inlet opening shall not be located within 3 feet (1 m) of a moisture exhaust duct, such as clothes dryer discharge or spa exhaust.

## High volume air supply ducting

As was previously discussed high volume installations require both an air supply and ventilation air openings into the mechanical room.

Recall that when any of the gas appliances in the room are equipped with draft control devices the air supply shall be located not less than 6 in. (150 mm) or more than 18 in. (450 mm) above the mechanical room floor. Whereas if none of the gas appliances are equipped with draft control devices then the air supply opening may be located anywhere in the mechanical room, if it does not interfere with the performance of the ventilation air opening (Figure 12).

The primary form of interference to be avoided involves the short circuiting of airflow, which could occur when ventilation and air supply openings are placed near to one another at the same level or on opposite walls at building corners where they are susceptible to wind suction effects. Locating the air supply opening below the ventilation air opening will assist proper air circulation.

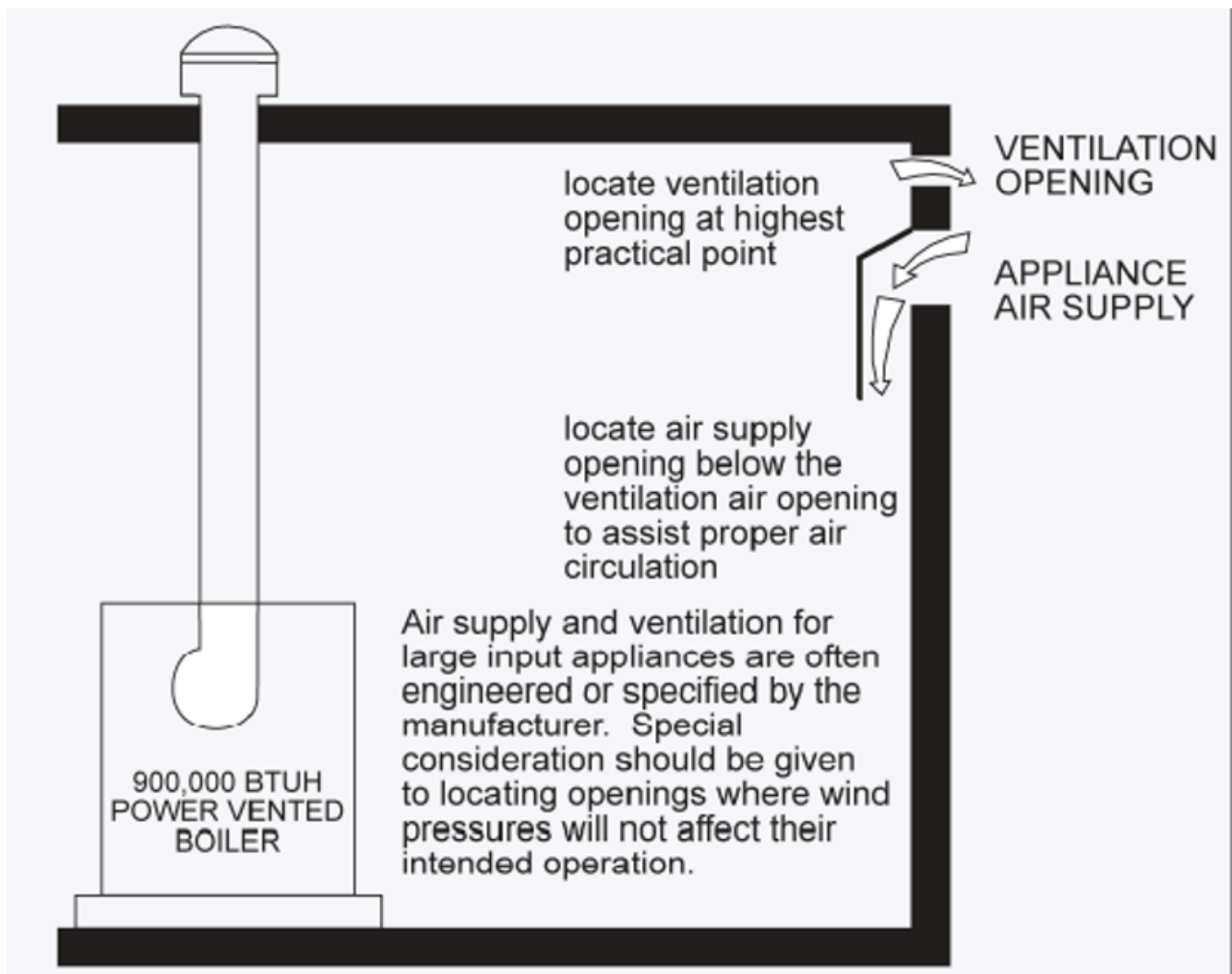

Figure 12. Outside air openings for large volume power burner

Whether or not you require ducting and how much will depend on the structure of the building and the appliance layout. For example, the mechanical room may be below grade, which could require both internal and external ducting. The design of the air supply and ventilation system for large volume installations is often engineered or specified by the equipment manufacturer but these must still be approved by the BC authority having jurisdiction.

## Duct installation

All duct work must be of metal or a material that meets the National standard (CAN/ULC-S110), requirements for materials used to fabricate air duct systems. These ducts are typically installed using rectangular or round galvanized sheet metal. As was seen on the Gas Code low volume sizing tables, the free area values are used to calculate the necessary rectangular duct dimension, and the round duct equivalent values can be used to select the appropriate round duct size.

Rectangular and square ducts have higher friction resistance to airflow than round ducts.

Square or rectangular ducts with dimension less than 3 in. cannot be used as the turbulence generated will significantly affect the free flow of air. For this reason, round ducts must always be used when the required free area is less than 9 in.<sup>2</sup>.

When the outside air supply enters the mechanical room, it must be located to avoid any problems that could result from cold air contacting piping, electrical, or mechanical equipment. The duct itself should also be suitably insulated and provided with a vapour barrier, to avoid condensation on its surface.

When air supply is brought to the appliance using the duct method, the overall length of duct as well as any changes of direction or other restrictions must be taken into consideration. When selecting the route for the duct every attempt should be made to limit the length of the duct and thus also limiting the air flow restriction. The required free area sizes listed in the Gas Code tables are based on a maximum equivalent duct length of 20 ft. If the length needs to exceed 20 ft of equivalent length the required size can be increase by one size to compensate for increased pipe friction losses. When increasing by one pipe size the new maximum equivalent length is 50 ft. In cases were the duct must exceed an equivalent length of 50 ft, a mechanical air supply would be required.

### **Equivalent Length or Effective Length**

Just as with piping systems and process fluids, duct fittings will add resistance to air flow. There are many manufacture and engineering tables available that quantify the friction loss created by the different fitting configurations. It is common to express the amount of resistance that a fitting creates as the equivalent length of straight pipe that would create the same pressure loss. The equivalent length of the fittings used gets added to the actual lengths of straight pipe to conclude the total equivalent length of the duct system. The sum of the straight lengths and the fitting equivalent lengths is also be referred to as the effective length of the duct.

Duct fitting equivalent lengths values vary for such things as; square, round, material type, angle, radius. For the example shown in Figure 13 we have used an equivalent of 10 ft for each 90 elbow which is a common value for 90-degree elbows. Assuming the louver that gets used is over sized to give the necessary equivalent free are of the duct we will not need to compensate for it. Therefore, lengths of the straight duct plus the equivalent length of the two elbows would give us an effective duct length of 34 ft Because the effective length of the duct is greater than 20 ft the size of the duct will need to be increased by one size over that required by the Code tables.

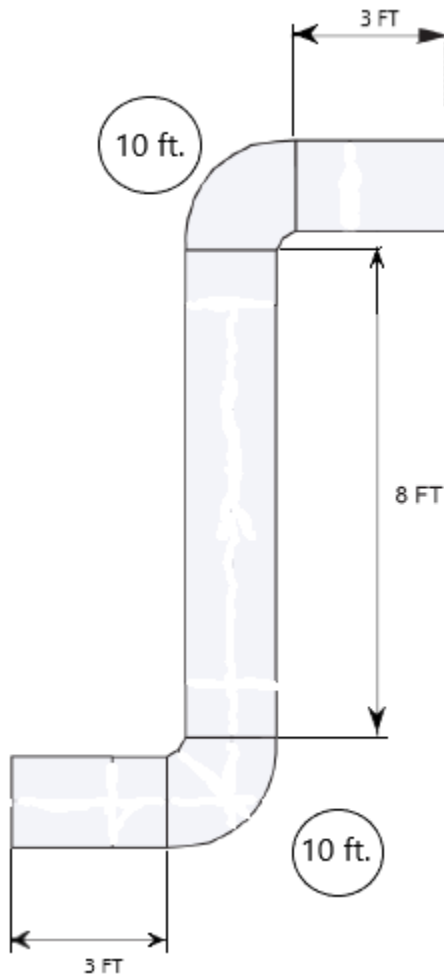

Figure 13. Effective duct length

## Duct assembly

On residential and small commercial installations prefabricated galvanized sheet metal duct materials are often used.

Round duct pipe and fittings come with crimped ends for easy assembly. They have a longitudinal snap lock seam. By shipping and storing pipe with the seam unconnected, multiple pipes can be nested within each other.

To create finished pipe lengths, start at the crimped end and snap the two sides together (Figure 14). Hold together with one hand and move down the pipe as the seam snaps in. When you get halfway, it should snap fully closed.

Round duct sections are fastened together or to fittings with self-tapping screws. This crimp connection makes a nearly air tight connection. If further sealing is needed the joint can be taped but this is not usually need for low pressure air supply applications.

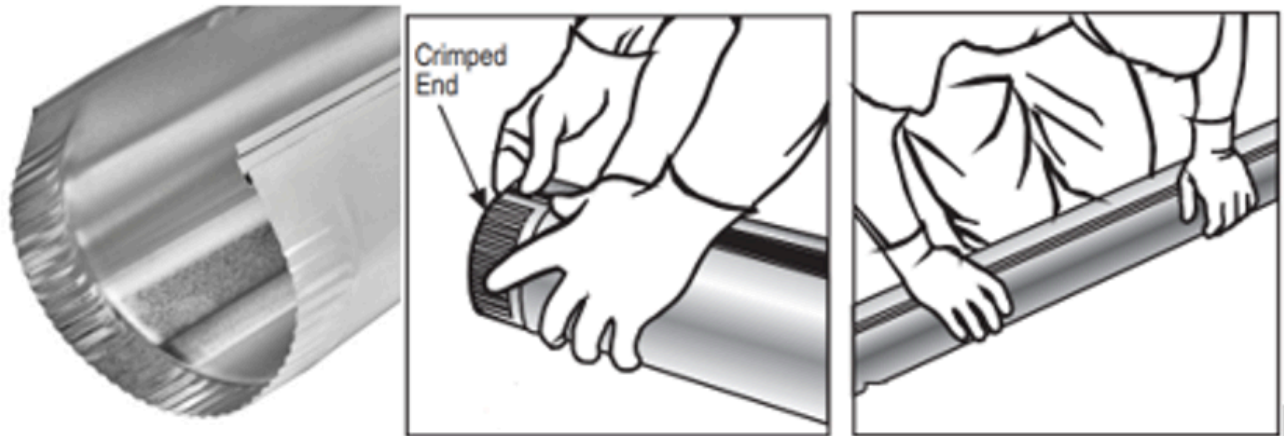

Figure 14. Round duct assembly

Pre-manufactured rectangular ducts are shipped in two L-shaped half sections (Figure 15). They are available in various lengths, 60 in. being most common. The two L-shaped half section are assembled using the two longitudinal button snap lock seams. Notice the two short sides have their ends turned over to create a Drive (hem)fold. Whereas the two long sides have raw edges.

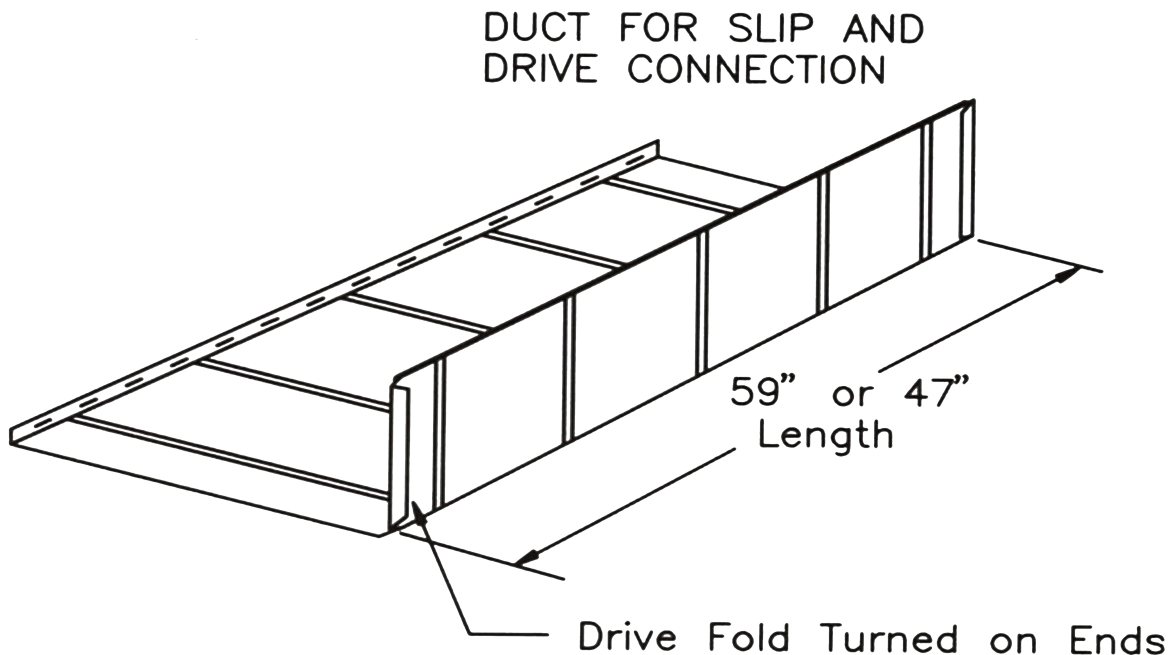

Figure 15. Rectangular duct half section

The standard means of connecting two assembled rectangular duct sections end to end (transverse joint) is to use sleeves of galvanized sheet metal called S-Cleats (Slip) and Drive Cleats (Figure 16). The drive cleat on the right has its two inside corners trimmed off. This will make it easier to get it started onto the two duct hems.

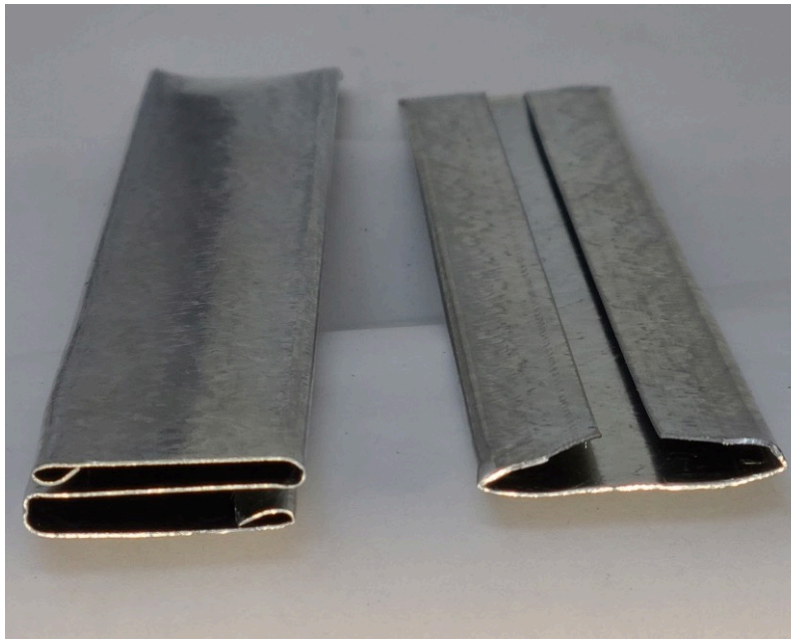

Figure 16. S-Cleat and Drive Cleat

You can see in Figure 17 the S-Cleats are used to connect the long side of the duct with the raw edges overlapped and slipped into the cleats. The drive cleats are used to pull together the two sections by hammering the Drive Cleat onto the two mated hemmed edges. Notice the Drive cleat has been cut to the approximate length and one end has already been bent over.

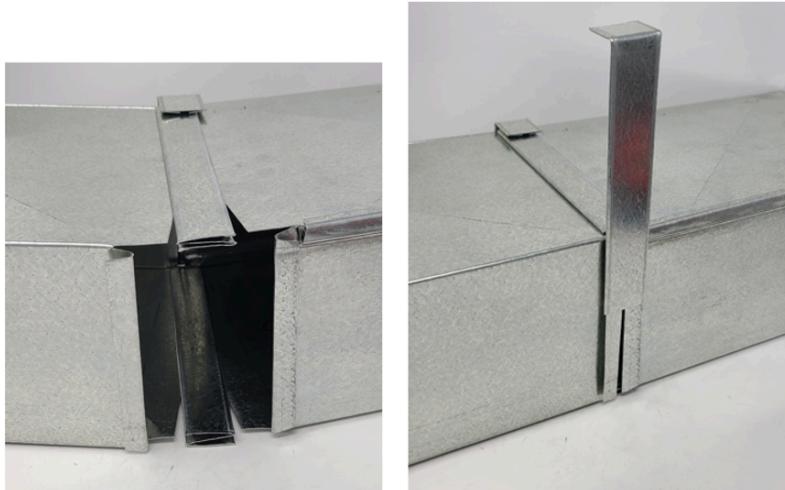

Figure 17. Assembling Slip & Drive Duct

## Terminations

The Code requirements for the inside duct terminal locations of both low and high volume have previously been identified. As was also mentioned, in cold climates you may want to provide insulation and a vapor barrier to minimize condensation on the outside surface of the duct. If cold air becomes a comfort problem, certified automatic and interlocked dampers are also available, which only open when the appliances are operating. You can also install a passive air trap on the inside termination. The

air trap is designed to use the different in buoyancy force of inside and outside air temperature, to inhibit the unwanted movement of air through the duct. The most common type is called a combustion air pot or bucket (Figure 18). A dotted line has been added to the picture (left), to show how the duct extends down into the bucket. Once the lower portion of the bucket fills with cold air it will not flow upward into the room until it is draw out of the bucket by a slight negative pressure being created when the appliance draws air from the room.



Figure 18. Combustion air pot/bucket

The outside termination clearance requirements related to finished grade and air contaminant have been previously discussed. Some addition outside termination considerations include flue gas vents, and gas regulator vents including gas meters. The clearance requirement from the air supply to vents and regulators are found within those sections of the Code book.

The minimum clearance requirements for a flue gas vent to a passive air supply opening are:

- 6 in. (150 mm) for inputs up to and including 10 000 Btuh (3 kW);
- 12 in. (300 mm) for inputs from 10 000 Btuh (3 kW) up to and including 10 0000 Btuh (30 kW);
- 3 ft (900 mm) for inputs exceeding 100 000 Btuh (30 kW)

*These listed inputs are from the vented appliance.*

The minimum clearance requirements for a gas regulator vent (including meter service regulator) to an appliance air supply are:

- 3 ft (1 m) for a vent serving a natural gas regulator
- 10 ft (3 m) for a vent serving a propane regulator

*The Gas Code allows for a clearance reduction to 1 ft (300 mm) for natural gas regulators, which have a certified internal device that restricts the rate in which gas can be expelled form the vent. See the code for the specific requirements*

The building envelop penetrations must be properly sealed to maintain the exterior seals and vapor barrier.

All direct vent appliances must have their air supply and vent piping terminations conform to the Gas code clearances as well as the manufactures instructions (Figure 19).



Figure 19. Direct vent terminations



Now complete Self-Test 3 and check your answers.

### Self-Test 3

#### Self-Test 3



An interactive H5P element has been excluded from this version of the text. You can view it online here:  
<https://opentextbc.ca/plumbing4b/?p=53#h5p-12>

### Media Attributions

- Figure 11. “Passive air supply terminations” – The source for this image is unknown. It is

being used for non-commercial, educational purposes. To receive credit for this image, please reach out to the publisher.

- Figure 12. “Outside air openings for large volume power burner” – The source for this image is unknown. It is being used for non-commercial, educational purposes. To receive credit for this image, please reach out to the publisher.
- Figure 13. “Effective duct length” by Camosun College is licensed under a [CC BY-NC-SA licence](#).
- Figure 14. “Round duct assembly” by Camosun College is licensed under a [CC BY-NC-SA licence](#).
- Figure 15. “[Rectangular duct half section](#)” from ECCO Manufacturing is used and adapted for educational purposes under the basis of fair dealing.
- Figure 16. “S-Cleat and Drive Cleat” by Camosun College is licensed under a [CC BY-NC-SA licence](#).
- Figure 17. “Assembling Slip & Drive Duct” by Camosun College is licensed under a [CC BY-NC-SA licence](#).
- Figure 18. “Combustion air pot/bucket” by Camosun College is licensed under a [CC BY-NC-SA licence](#).
- Figure 19. “Direct vent terminations” by Camosun College is licensed under a [CC BY-NC-SA licence](#).

## Appendix 1: Self-Tests

This chapter contains all of the Self-Tests in a text format. Answers can be found in [Appendix 2: Self-Test Answer Keys](#).

### Competency B1, Self-Test 1

Found in [Competency B1, Learning Task 1](#).

#### Self-Test 1

1. The appliance shut-off valve is typically located just inside the appliance service cover, where it can be easily reached.
  - a. True
  - b. False
2. Most gas shut-off applications will require the use of a manual valve that will fully open or close with a quarter-turn of the handle.
  - a. True
  - b. False
3. A valve's Water, Oil and Gas (WOG) pressure rating includes the maximum approved pressure for use on fuel gas applications.
  - a. True
  - b. False
4. A threaded brass ball valve has the following markings: 600 WOG, 150 WSP, 1/2 G, 5G, CGA 3.16. What is the maximum certified pressure rating for combustible gas applications?
  - a. 1/2 psig
  - b. 5 psig
  - c. 125 psig
  - d. 600 psig
5. A standard port ball valve has an opening through the ball that is one pipe size smaller than the valve's connection size.
  - a. True

- b. False
6. A Luboseal™ gas valve must be shut off in order to be relubricated.
- a. True
  - b. False
7. Butterfly, globe and needle valves are commonly used as appliance shut-off valve.
- a. True
  - b. False
8. What is the colour of the valve handles on approved gas valves?
- a. Red
  - b. Blue
  - c. Yellow
  - d. Any of the choices

Check your answers using the [Self-Test Answer Keys](#) in Appendix 2.

## B1 Self-Test 2

Found in [Competency B1, Self-Test 2](#).

### Self-Test 2

1. Where is the appliance regulator located in relation to the automatic gas valve?
  - a. On the pilot line
  - b. Upstream of the automatic gas valve
  - c. Downstream of the automatic gas valve
  - d. Upstream of the appliance manual shut-off valve
2. The A-Cock is a manual shut-off valve used to adjust the pilot burner.
  - a. True
  - b. False
3. Which gas code contains the requirements for the field assembly of gas valve trains?
  - a. CSA B149.1

- b. CSA B149.2
  - c. CSA B149.3
  - d. CSA B149.5
4. What is the name of the systems were the automatic safety shut-off valve stops the gas flow to both the main burner and the pilot burner?
- a. 80% safe
  - b. Wild pilot
  - c. 100% safe
  - d. Non-100% safe
5. An electric automatic gas valve is normally operated by 120 VAC.
- a. True
  - b. False

Check your answers using the [Self-Test Answer Keys](#) in Appendix 2.

## B1, Self-Test 3

Found in [Competency B1, Learning Task 3](#).

### Self-Test 3

1. What is the restricting element of a regulator?
  - a. Spring
  - b. Valve disc
  - c. Diaphragm
  - d. Atmospheric vent
2. What is the measuring element of a regulator?
  - a. Spring
  - b. Valve disc
  - c. Diaphragm
  - d. Atmospheric vent
3. What is the loading element of a regulator?

- a. Spring
  - b. Valve disc
  - c. Diaphragm
  - d. Atmospheric vent
4. What is the purpose of a gas pressure regulator?
- a. To keep the colour of the flame constant
  - b. To maintain even outlet heated air temperatures
  - c. To maintain a constant gas pressure at the gas valve inlet
  - d. To increase and maintain higher pressures as the load increases
5. In a gas pressure regulator, how is the closing force is created?
- a. Decreased flow velocity
  - b. The inlet pressure to the regulator
  - c. The outlet pressure under the diaphragm
  - d. The adjustable spring above the diaphragm
6. In a gas pressure regulator, how is the opening force is created?
- a. Increased flow velocity
  - b. The inlet pressure to the regulator
  - c. The pressure under the diaphragm
  - d. The adjustable spring above the diaphragm
7. How is the downstream pressure of the regulator increased?
- a. The orifice size is changed
  - b. The adjusting screw is screwed out
  - c. The adjusting screw is screwed down
  - d. Replace the restricting disc and the spring
8. What is the purpose of the regulator atmospheric vent?
- a. Allow gas to escape
  - b. Sense downstream pressure
  - c. Allow the regulator to breath
  - d. Allow a connection for a secondary pilot
9. When is a pressure regulator said to be in equilibrium?
- a. Opening force of the diaphragm is equal to the closing force of the orifice
  - b. Opening force of the diaphragm is equal to the closing force of the spring

- c. Opening force of the spring is equal to the closing force of the upstream pressure
  - d. Opening force of the spring is equal to the closing force of the downstream pressure
10. What term describes the condition when the outlet pressure is lower than set point pressure during flow conditions?
- a. Rise
  - b. Boost
  - c. Droop
  - d. Lockup
11. If a regulator is installed backwards in a piping system, what is the most likely result?
- a. The regulator will open completely
  - b. The regulator will close completely
  - c. Pressure downstream will rise above set point
  - d. No difference – they are non-directional valves
12. What is the purpose of a pitot tube in a regulator?
- a. Provide mechanical advantage for positive shut-off
  - b. Relieve unwanted gases when overpressure occurs
  - c. Increase upstream pressure during static conditions
  - d. Keep downstream pressure closer to set point during flow conditions
13. What is the purpose of the addition of a lever in a regulator?
- a. Provide mechanical advantage for positive shut-off
  - b. Relieve unwanted gases when overpressure occurs
  - c. Increase upstream pressure during static conditions
  - d. Keep downstream pressure closer to set point during flow conditions
14. When flow rate increases through a regulator, what happens to the downstream pressure?
- a. It increases
  - b. It decreases
  - c. It cycles/hunts
  - d. It stays the same
15. Which category of gas pressure regulators are used to reduce the service line pressure to building line pressure at the gas meter set?
- a. Service regulators
  - b. Appliance regulators

- c. First-stage regulators
  - d. Line pressure regulators
16. What is the most likely result of a partially restricted regulator vent?
- a. Pilot safety to fail
  - b. Restricting element to stay fully open
  - c. Restricting element to stay fully closed
  - d. Regulator to respond slow or sluggish
17. What is “lockup pressure”?
- a. The pressure downstream of a regulator under no flow conditions
  - b. The pressure downstream of a regulator under full flow conditions
  - c. The pressure downstream of a regulator during full relief conditions
  - d. The pressure downstream of a regulator which activates the internal relief valve
18. What is the maximum allowed propane pressure in a single-family dwelling?
- a. 7” WC
  - b. 14” WC
  - c. 2 psig
  - d. 5 psig
19. What type of regulator arrangement is required in all permanent propane installations?
- a. Two stage regulation
  - b. Proportioning regulation
  - c. Zero governor regulation
  - d. Balance diagram regulation
20. What are the typical setpoints for a two-stage propane regulator?
- a. First stage 14” wc, Second stage 7” wc
  - b. First stage 2 psig, Second stage 14” wc
  - c. First stage 5 psig, Second stage 2 psig
  - d. First stage 10 psig, Second stage 11” wc
21. What units are usually used to express the rate of flow for a regulator?
- a. SCFH
  - b. BTUH
  - c. MBH
  - d. KWH

22. When installing an appliance regulator the vent opening is completely blocked. This will cause the regulator to:
- remain permanently open
  - go into a hunting condition
  - remain permanently closed
  - regulate the gas flow at the correct pressure
23. What is the purpose of a pitot tube in a regulator?
- to provide mechanical advantage for positive shut-off
  - to relieve unwanted gases when overpressure occurs
  - to increase upstream pressure during static conditions
  - to keep downstream pressure closer to set point during flow conditions.
24. What position is the valve seat of a zero govern/ratio regulator when deenergized.
- Normally open
  - Normally closed

Check your answers using the [Self-Test Answer Keys](#) in Appendix 2.

## B1, Self-Test 4

Found in [Competency B1, Learning Task 4](#).

### Self-Test 4

- The rod and tube actuator operates on which principle?
  - Electro-magnetism
  - Thermoelectric effect
  - Thermal expansion of solids
  - Thermal expansion of liquids
- Sealed bellows actuator operates on which principle?
  - Electro-magnetism
  - Thermoelectric effect
  - Thermal expansion of solids

- d. Thermal expansion of liquids
3. Solenoids operate on which principle?
    - a. Electro-magnetism
    - b. Thermoelectric effect
    - c. Thermal expansion of solids
    - d. Thermal expansion of liquids
  4. What control components produce electricity when heated?
    - a. Transistor
    - b. Thermistor
    - c. Thermocouple
    - d. Bimetallic strip
  5. On what type of gas appliance would a rod and Tube (Unitrol) valve typically be installed?
    - a. Gas range
    - b. Gas boiler
    - c. Gas Furnace
    - d. Gas water heater
  6. In a Unitrol gas-fired water heater control, what is the purpose of the snap operating mechanism?
    - a. To prevent override
    - b. To prevent undershoot
    - c. To open or close the valve seat faster
    - d. To shut down the burner in an unsafe condition
  7. Pilot operated solenoid valves use pressure differential to assist the plunger in opening and closing the main valve.
    - a. True
    - b. False
  8. The servo regulator built into a combination gas valve serves as which type of gas pressure regulator?
    - a. System regulator
    - b. Service regulator
    - c. Appliance regulator
    - d. Over pressure protection regulator
  9. What is the name of the backup safety designed to shut off the burner if the temperature of the water in the heater exceeds 2 000 F?

- a. T&P
  - b. ECO
  - c. TCO
  - d. FVIR
10. What feature acts as extra protection on a redundant gas valve?
- a. On-off switch
  - b. Pilot adjustment
  - c. Servo regulator
  - d. A second automatic shutoff valve seat
11. How have redundant combination gas valves been adapted to give them modulating operation?
- a. WiFi-enabled
  - b. Servo regulated
  - c. Electric Stepper motor
  - d. Electro hydraulic actuator
12. On an electric oven safety valve, the HSI must warm up sufficiently before enough electricity can pass to open the gas valve.
- a. True
  - b. False
13. A seismic valve will reset automatically once the vibration stops.
- a. True
  - b. False
14. Cable release fire suppression gas valves can only be activated manually.
- a. True
  - b. False
15. What are the typical manifold pressure ranges from a two stage gas valve supplying CH<sub>4</sub>?
- a. Low Fire 1 in. WC, High Fire 1.5 in. WC
  - b. Low Fire 1 – 1.5 in. WC, High Fire 3 – 4 in. WC.
  - c. Low Fire 3 in. WC, High Fire 4 in. WC
  - d. Low Fire 3 –4 in. WC, High Fire 10 – 11 in. WC.
16. On a “Call for Heat” condition with a rod and tube control valve, which of the following statements is correct?
- a. The copper tube has expanded and the gas valve is open.

- b. The Invar rod has expanded and the gas valve is closed.
  - c. The copper tube has contracted and the Invar rod has opened the gas valve.
  - d. The Invar rod has expanded and the copper tube has opened the gas valve.
17. A solenoid gas valve is in the open position when:
- a. the coil is energized
  - b. the valve is pressurized
  - c. the coil is not energized
  - d. the valve is not pressurized
18. Which of the following voltages would not be used to energize a diaphragm gas valve?
- a. 30 MV
  - b. 750 MV
  - c. 24 V
  - d. 120 V
19. Which of the following voltages could be used to energize a solenoid gas valve?
- a. 10 MV
  - b. 30 MV
  - c. 750 MV
  - d. 24 V
20. A solenoid gas valve would be installed:
- a. upstream of the safety valve
  - b. downstream of the safety valve
  - c. upstream of the pilot connection
  - d. upstream of the appliance regulator
21. The closing force of a diaphragm gas valve is:
- a. outlet gas pressure and total force
  - b. inlet gas pressure and spring pressure
  - c. outlet gas pressure and spring pressure
  - d. inlet gas pressure and electro-magnetism
22. A servo pressure regulator controls:
- a. the pressure to the pilot burner
  - b. the pressure to the main burner
  - c. the pressure to the SSOV (safety shut-off valve)

- d. the pressure to both the main burner and the pilot burner
23. Which of the following valves would never require electricity to operate?
- a. Seismic valve
  - b. Solenoid gas valve
  - c. Diaphragm gas valve
  - d. Redundant gas valve
24. Which of the following valves would be used with an intermittent pilot system?
- a. Solenoid gas valve
  - b. Safety shut-off valve
  - c. Diaphragm gas valve
  - d. Redundant gas valve
25. A solenoid gas valve installed upside down may:
- a. remain fully open and never close
  - b. open very slowly causing flashback
  - c. open very quickly causing flame lift off
  - d. stay closed when the valve is energized
26. The safety shut-off valve is held open by:
- a. spring pressure
  - b. a thermocouple
  - c. atmospheric pressure
  - d. gas pressure under the diaphragm
27. A FV sensor reacts to the ignition of flammable vapours in the combustion chamber.
- a. True
  - b. False
28. How does a modulating hydraulic gas valve react on an initial call for heat?
- a. Snaps open to fully open position
  - b. Snaps open to modulated input
  - c. Snaps open to a pre-set minimum input
  - d. Slowly opens to the proportional modulated position

Check your answers using the [Self-Test Answer Keys](#) in Appendix 2.

## B2, Self-Test 1

Found in [Competency B2, Learning Task 1](#).

### Self-Test 1

1. The Water, Oil and Gas (WOG) pressure rating covers flammable gas applications.
  - a. True
  - b. False
2. Ball valves with a 5G rating are good for up to 5 psi gas installations indoors and outdoors.
  - a. True
  - b. False
3. Repair or replacement of two-piece ball valves internal parts is not recommended.
  - a. True
  - b. False
4. How can a ball valve stem leak be fixed?
  - a. Lubricate the ball valve
  - b. Tighten the handle nut
  - c. Remove the handle and tighten the packing nut
  - d. Use two wrenches to tighten the two halves of the valve body
5. Lubricated gas valves are equipped with a SAE standard grease fitting.
  - a. True
  - b. False
6. Lubricated gas valves require monthly relubrication.
  - a. True
  - b. False
7. How are button head grease couplers are installed onto the fitting?
  - a. Push onto the fitting
  - b. Pulls onto the fitting
  - c. Screw into the fitting
  - d. Push and  $\frac{1}{4}$  turn twist action

Check your answers using the [Self-Test Answer Keys](#) in Appendix 2.

## B2, Self-Test 2

Found in [Competency B2, Learning Task 2](#).

### Self-Test 2

1. Any gas piping passing through a wall is defined as concealed piping
  - a. True
  - b. False
2. The gas code stipulates that, a line pressure or high pressure regulator must be provide with OPP when installed, with a supply pressure greater than what?
  - a. ½ psig
  - b. 2 psig
  - c. 5 psig
  - d. 10 psig
3. What is the maximum allowable pressure downstream of a pressure controlling device?
  - a. 2 psig
  - b. 5 psig
  - c. Lowest maximum pressure rating of any downstream components
  - d. Highest maximum pressure rating of any downstream components
4. Direct operated relief valves are supplied in the normally open position.
  - a. True
  - b. False
5. A direct operated relief valve looks like an ordinary direct-operated regulator except that it senses upstream pressure rather than downstream pressure.
  - a. True
  - b. False
6. An overpressure shut-off (OPSO) will automatically reset.
  - a. True
  - b. False
7. The vent limiting orifice has a very small orifice opening that will restrict the air flow which will delay the regulators reaction time.

- a. True
  - b. False
8. When using a regulator with a ball check leak limiters what must you ensure?
- a. It is not installed outdoors
  - b. The leak limiting device must be in the vertical position
  - c. The regulator is installed in a ventilated space
  - d. All of the above
9. If a 5 psig line pressure regulator has a  $\frac{3}{4}$  inch vent tapping and the vent line must run 65 feet, what must be done?
- a. Use  $\frac{3}{4}$  inch pipe for the first 20 feet, then increase to 1 inch
  - b. Use  $\frac{3}{4}$  inch pipe for the first 50 feet, then increase to 1 inch
  - c. Use  $\frac{3}{4}$  inch pipe for the entire length – you may not change sizes
  - d. Use 1 inch pipe for the entire length – make the change at the vent tapping
10. Too many fittings on a vent line could cause:
- a. the regulator to “hunt”
  - b. the regulator to lock-up
  - c. the restricting element to fully close
  - d. the restricting element to fully open
11. If a 5 psig line-pressure regulator (with internal relief) was installed in a boiler room, which of the following would be required?
- a. A bypass shall be installed
  - b. It shall be of negative shut-down type
  - c. The vent must be piped to a safe location outdoors
  - d. All downstream piping must be Type “K” copper tubing
12. A line pressure regulator operating at 2 psig or less shall be exempt from the requirements of Clause 5.2.1.7 (B) when equipped with which of the following?
- a. A vent leak-limiting system
  - b. An internal relief valve spring
  - c. A union on the downstream piping
  - d. A pitot tube and balancing diaphragm
13. The arrow on a regulator body should point upstream.
- a. True
  - b. False

14. What is the minimum clearance from a regulator vent termination to a mechanical air intake?
- 1 ft
  - 3 ft
  - 10 ft
  - 15 ft
15. What is the minimum clearance from a regulator vent termination to an electrical outlet?
- 1 ft
  - 3 ft
  - 10 ft
  - 15 ft

Check your answers using the [Self-Test Answer Keys](#) in Appendix 2.

## B3, Self-Test 1

Found in [Competency B3, Learning Task 1](#).

### Self-Test 1

- System pressure tests can be performed with compressed Oxygen.
  - True
  - False
- What are the minimum pressure test requirements for the unconnected (stage 1) test, of a 5 psi system 70 meter in length.
  - 15 psi for 15 minutes
  - 15 psi for 60 minutes
  - 50 psi for 60 minutes
  - 50 psi for 180 minutes
- A 3" pressure gauge with a 50 psi maximum range and 1 psi pressure increments would be acceptable to use for a 15 psi pressure test.
  - True
  - False

4. Line pressure (system) regulators should be installed for the Stage 1 pressure test.
  - a. True
  - b. False
5. What is the purpose of the valve seepage test?
  - a. To verify that the supply valve is closed tight
  - b. To verify there are no open ends in the system
  - c. To verify the appliance control valve is closing tight
  - d. To verify the regulator is closing tight at positive lockup pressure
6. A partially full nitrogen cylinder has 800 psig it has an internal volume of 1.77 ft<sup>3</sup> (50 L). How much gas will be available for a 50 psig pressure test?
  - a. 8.1 ft<sup>3</sup> (230 L)
  - b. 22.28 ft<sup>3</sup> (630.5 L)
  - c. 28.32 ft<sup>3</sup>(801.5 L)
  - d. 632.5 ft<sup>3</sup> (1789 L)

Check your answers using the [Self-Test Answer Keys](#) in Appendix 2.

## B3, Self-Test 2

Found in [Competency B2, Learning Task 2](#).

### Self-Test 2

1. As per the gas code a 2 psig 3" NPS natural gas pipeline that is 40 ft in length must first be purged with inert gas and then purged with the fuel gas.
  - a. True
  - b. False
2. The purging of gas system supplying a 500 000 Btu/h appliance ca be performed and or supervised by a class B gas fitter.
  - a. True
  - b. False
3. Purging is done before the line have been pressure tested.

- a. True
  - b. False
4. If you have a gas range the entire piping system can be purged indoors using one of the ranges open burners.
- a. True
  - b. False
5. As per the Gas Code what is the maximum gas system pressure that may be purged using the indoor hose purge assembly method?
- a. 7" wc
  - b. 11" wc
  - c. 2 psi
  - d. 5 psi
6. As per the Gas Code what is the maximum pipe size that may be purged using the indoor hose purge assembly method?
- a. ½" NPS
  - b. ¾" NPS
  - c. 1" NPS
  - d. 4" NPS
7. As per the Gas Code what is the maximum length of piping that may be purged using the indoor hose purge assembly method?
- a. 50 ft
  - b. 100 ft
  - c. 200 ft
  - d. No maximum length

Check your answers using the [Self-Test Answer Keys](#) in Appendix 2.

## B4, Self-Test 1

Found in [Competency B4, Learning Task 1](#).

## Self-Test 1

1. What term describes the unintentional act of air entering through the building envelope?
  - a. Infiltration
  - b. Exfiltration
  - c. Stack effect
  - d. Distribution effect
2. Pressure induced backdrafting is the reversal of the flow of flue gases out of the building caused by negative pressure in the building.
  - a. True
  - b. False
3. What is the maximum house depressurization limit (HDL) that a natural draft vented appliance should be exposed to?
  - a. 1 Pa (.004" wc)
  - b. 5 Pa (.02" wc)
  - c. 10 Pa (.04" wc)
  - d. 15 Pa (.06" wc)
4. What are the two common methods of delivering the air supply requirements to a gas appliance?
  - a. Induced and Forced draft
  - b. Direct vent and room air systems
  - c. Primary and secondary
  - d. Make-up and ventilation air
5. When installing a twin pipe direct vent appliance the air supply must be sized and installed according to the requirements of the B149.1 Gas code.
  - a. True
  - b. False

Check your answers using the [Self-Test Answer Keys](#) in Appendix 2.

## B4, Self-Test 2

Found in [Competency B4, Learning Task 2](#).

## Self-Test 2

1. How are air supply requirements for a direct vent appliance determined?
  - a. Table 8.1
  - b. Table 8.2
  - c. Code clause 8.2.6
  - d. Manufacturer's literature
2. What is the minimum required free area of a square combustion air opening?
  - a. 3 in.<sup>2</sup>
  - b. 6 in.<sup>2</sup>
  - c. 9 in.<sup>2</sup>
  - d. 10 in.<sup>2</sup>
3. What is the smallest opening dimension in a fixed louvre, grille, or screen?
  - a.  $\frac{1}{8}$ "
  - b.  $\frac{1}{4}$ "
  - c.  $\frac{1}{2}$ "
  - d. 1"
4. Under what conditions can a gas-fired appliance be installed in a building and not have a separate combustion air supply?
  - a. Tight building of sufficient volume
  - b. Loose building of less than 1 000 ft<sup>2</sup>
  - c. Loose building of sufficient volume
  - d. Tight building appliance in an enclosure
5. When compared to the air supply opening, what is the minimum cross-sectional area of the ventilation air opening for an appliance over 400 MBH?
  - a. 5% or 5 in.<sup>2</sup>
  - b. 10% or 10 in.<sup>2</sup>
  - c. 20% or 20 in.<sup>2</sup>
  - d. 50% or 50 in.<sup>2</sup>

6. A single family dwelling complies with Clause 8.2.1(a) or (b). It has a boiler rated at 200 MBH and a hot water storage tank rated at 110 MBH. Both appliances are equipped with draft control devices. The air supply is brought from outdoors through a duct. Determine the area of air supply duct.
- 22 in.<sup>2</sup>
  - 25 in.<sup>2</sup>
  - 40 in.<sup>2</sup>
  - 47 in.<sup>2</sup>
7. A structure conforms to Clause 8.2.1(a) or (b). It contains a boiler rated at 65 MBH and a domestic hot water tank rated at 40 MBH. Both appliances are designed for use with no draft control devices and the air supply is brought from outdoors through a duct. Determine the area of air supply duct.
- 7 in.<sup>2</sup>
  - 9 in.<sup>2</sup>
  - 14 in.<sup>2</sup>
  - 18 in.<sup>2</sup>
8. A single family dwelling conforms to Clause 8.2.1(a) or (b). It has a furnace rated at 80 kW and a hot water tank rated at 30 kW. The furnace is equipped with a barometric draft control and the hot water tank has a draft-hood. The air supply is from outdoors. Determine the area of air supply duct.
- 12 000 mm<sup>2</sup>
  - 14 000 mm<sup>2</sup>
  - 30 000 mm<sup>2</sup>
  - 35 000 mm<sup>2</sup>
9. A structure conforms to Clause 8.2.1(a) or (b). It has a mid-efficient furnace rated at 150 MBH and a hot water tank with an input of 40 MBH. The furnace has no draft control device, but the hot water tank is equipped with a draft-hood. The air supply is from outdoors. Determine the area of air supply duct.
- 4 in.<sup>2</sup>
  - 14 in.<sup>2</sup>
  - 29 in.<sup>2</sup>
  - 18 in.<sup>2</sup>
10. A structure does not comply with Clause 8.2.1(a) or (b). It is equipped with a boiler rated at 150 MBH and a hot water tank rated at 60 MBH. Both appliances are equipped with draft control devices. The volume of the structure is 8 000 cu ft Determine the area of air supply duct.
- 16 in.<sup>2</sup>
  - 29 in.<sup>2</sup>

- c. 32 in.<sup>2</sup>  
d. None required
11. A structure does not conform to Clause 8.2.1(a) or (b). It is equipped with a boiler rated at 225 MBH and a hot water tank rated at 50 MBH. Both appliances do not use a draft control device and the volume of the structure is 10 000 cu ft Determine the area of air supply duct.
- a. 20 in.<sup>2</sup>  
b. 32 in.<sup>2</sup>  
c. 40 in.<sup>2</sup>  
d. None required
12. A boiler room is located within an enclosure in a structure that does not comply with Clause 8.2.1(a) or (b). The boiler is rated at 200 MBH and a hot water tank is rated at 60 MBH. Both units are equipped with draft-hoods. The volume of the structure is 20 000 cu ft and Table 8.3 indicates that the air supply may be taken from the structure. Calculate the area of openings required to be cut into the enclosure.
- a. 20 in.<sup>2</sup>  
b. 260 in.<sup>2</sup> upper and lower  
c. 260 in.<sup>2</sup> upper opening only  
d. 260 in.<sup>2</sup> lower opening only
13. A mechanical room is equipped with gas appliances with a total input of 1 800 MBH. All appliances are equipped with draft control devices. Determine the free area of air supply opening.
- a. 18 in.<sup>2</sup>  
b. 60 in.<sup>2</sup>  
c. 201 in.<sup>2</sup>  
d. 260 in.<sup>2</sup>
14. A structure is equipped with a boiler rated at 400 MBH and a hot water tank rated at 80 MBH. Both pieces of equipment are equipped with draft control devices and the air supply is ducted from outdoors. Determine the free area of ventilation opening
- a. 7 in.<sup>2</sup>  
b. 10 in.<sup>2</sup>  
c. 12 in.<sup>2</sup>  
d. 68 in.<sup>2</sup>
15. A structure is equipped with a boiler rated at 1 000 kW and has a barometric draft control. The louvered opening has 65% free area. Determine the area of air supply opening.
- a. 70 000 mm<sup>2</sup>  
b. 201 500 mm<sup>2</sup>

- c. 310 000 mm<sup>2</sup>  
d. None required
16. A structure is equipped with appliances rated at 2 000 MBH. None of the appliances are equipped with draft control devices. Determine the free area of air supply opening.
- a. 10 in.<sup>2</sup>  
b. 67 in.<sup>2</sup>  
c. 214 in.<sup>2</sup>  
d. 285 in.<sup>2</sup>
17. A structure has a mechanical room into which air must be ducted from outdoors. It contains the following appliances:
- One boiler rated at 1 200 MBH, equipped with a barometric damper.
  - Two duct heaters without draft controls rated at 600 MBH each.
  - Two hot water tanks rated at 300 MBH each. Both tanks are equipped with draft-hoods.

Determine the free area of air supply opening:

- a. 80 in.<sup>2</sup>  
b. 171 in.<sup>2</sup>  
c. 220 in.<sup>2</sup>  
d. 240 in.<sup>2</sup>
18. Calculate the air requirements supplied from outdoors to a mechanical room equipped with the following appliances:
- One boiler with a draft control at 200 kW.
  - One boiler with no draft control rated at 100 kW.
  - Two duct heaters with no draft control rated at 50 kW each.
  - Two hot water tanks with draft-hoods at 100 kW each.

Determine the free area of ventilation opening:

- a. 4 200 mm<sup>2</sup>  
b. 11 250 mm<sup>2</sup>  
c. 12 250 mm<sup>2</sup>  
d. 13 950 mm<sup>2</sup>

Check your answers using the [Self-Test Answer Keys](#) in Appendix 2.

## B4, Self-Test 3

Found in [Competency B4, Learning Task 3](#).

### Self-Test 3

1. If there is more than one gas appliance in the area, the air supply can be located at any appliance.
  - a. True
  - b. False
2. What minimum distance must the air supply opening be located above the finished grade?
  - a. 12 in.
  - b. 18 in.
  - c. 24 in.
  - d. 36 in.
3. What is the maximum vertical distance above the burner level that the air supply can terminate on a low volume installation?
  - a. 6 in.
  - b. 12 in.
  - c. 18 in.
  - d. 24 in.
4. The outside opening for an air supply can not terminate any closer than what distance from a clothes dryer vent?
  - a. 12 in.
  - b. 18 in.
  - c. 24 in.
  - d. 36 in.
5. Mechanical room has one 500 MBH boiler with a draft control device, the air supply can be located anywhere in the mechanical room, provided that it does not interfere with the performance of the ventilation air opening.
  - a. True
  - b. False
6. When using the low volume air supply tables, what is the maximum equivalent length if the duct is oversized by one?

- a. 10 ft
  - b. 20 ft
  - c. 40 ft
  - d. 50 ft
7. When connecting two rectangular ducts the S-cleats are used to joint the two folded (hemmed) edges.
- a. True
  - b. False
8. A combustion air pot is a type of passive air trap designed to to inhibit the unwanted movement of air through the duct.
- a. True
  - b. False
9. What is the minimum clearance requirement from a passive air supply opening to a flue gas vent serving a 100 MBH appliance?
- a. 6 in.
  - b. 12 in.
  - c. 3 ft
  - d. 10 ft

Check your answers using the [Self-Test Answer Keys](#) in Appendix 2.

## Appendix 2: Self-Test Answer Keys

### Competency B1

#### Self-Test 1

- |             |                |                          |
|-------------|----------------|--------------------------|
| 1. b. False | 4. c. 125 psig | 7. b. False              |
| 2. a. True  | 5. a. True     | 8. d. Any of the choices |
| 3. b. False | 6. b. False    |                          |

#### Self-Test 2

- |   |                  |                 |
|---|------------------|-----------------|
| 1. b. Upstream of the automatic gas valve | 2. b. False      | 4. c. 100% safe |
|   | 3. c. CSA B149.3 | 5. b. False     |

#### Self-Test 3

- |  |  |  |
|--|--|--|
| 1. b. Valve disc   | spring is equal to the   | slow or sluggish   |
| 2. c. Diaphragm  | closing force of the   |  |
| 3. a. Spring   | downstream pressure  | 17. a. The pressure  |
| 4. c. To maintain a constant gas pressure at the gas valve inlet | 10. c. Droop   | downstream of a regulator under no flow conditions                             |
| 5. c. The outlet pressure under the diaphragm                    | 11. b. The regulator will close completely                                 | 18. c. 2 psig  |
| 6. d. The adjustable spring above the diaphragm                  | 12. d. Keep downstream pressure closer to set point during flow conditions | 19. a. Two stage regulation  |
| 7. c. The adjusting screw is screwed down                        | 13. a. Provide mechanical advantage for positive shut-off                  | 20. c. First stage 5 psig, Second stage 2 psig                                 |
| 8. c. Allow the regulator to breath                              | 14. b. It decreases  | 21. d. MBH   |
| 9. d. Opening force of the                                       | 15. a. Service regulators  | 22. a. remain permanently open   |
|  | 16. d. Regulator to respond  | 23. d. to keep downstream pressure closer to set point during flow conditions. |
|  |  | 24. b. Normally closed   |

#### Self-Test 4

- |                                   |                            |
|-----------------------------------|----------------------------|
| 1. c. Thermal expansion of solids | 2. d. Thermal expansion of |
|-----------------------------------|----------------------------|

- |  |   |   |
|--|---|---|
| liquids                                      | 13. b. False  | 21. b. inlet gas pressure and spring pressure |
| 3. a. Electro-magnetism                      | 14. b. False  | 22. b. the pressure to the main burner        |
| 4. c. Thermocouple                           | 15. b. Low Fire 1 – 1.5 in.WC, High Fire 3 – 4 in. WC.                            | 23. a. Seismic valve                          |
| 5. d. Gas water heater                       | 16. c. The copper tube has contracted and the Invar rod has opened the gas valve. | 24. d. Redundant gas valve                    |
| 6. c. To open or close the valve seat faster | 17. a. the coil is energized  | 25. a. remain fully open and never close      |
| 7. a. True                                   | 18. a. 30 MV  | 26. b. a thermocouple                         |
| 8. c. Appliance regulator                    | 19. d. 24 MV  | 27. b. False                                  |
| 9. b. ECO                                    | 20. b. downstream of the safety valve   | 28. c. Snaps open to a pre-set minimum input  |
| 10. d. A second automatic shutoff valve seat |   |   |
| 11. c. Electric Stepper motor                |   |   |
| 12. a. True                                  |   |   |

## Competency B2

### Self-Test 1

- |             |   |                              |
|-------------|---|------------------------------|
| 1. b. False | 4. c. Remove the handle and tighten the packing nut | 6. b. False                  |
| 2. a. True  | 5. b. False   | 7. b. Pulls onto the fitting |
| 3. a. True  |   |                              |

### Self-Test 2

- |   |   |   |
|---|---|---|
| 1. b. False   | 6. b. False   | 11. c. The vent must be piped to a safe location outdoors |
| 2. b. 2 psig  | 7. a. True  | 12. a. A vent leak-limiting system                        |
| 3. c. Lowest maximum pressure rating of any downstream components | 8. d. All of the above  | 13. b. False  |
| 4. b. False   | 9. d. Use 1 inch pipe for the entire length – make the change at the vent tapping | 14. c. 10 ft  |
| 5. a. True  | 10. a. the regulator to “hunt”  | 15. b. 3 ft   |

## Competency B3

### Self-Test 1

- |             |                              |             |
|-------------|------------------------------|-------------|
| 1. b. False | 2. d. 50 psi for 180 minutes | 3. b. False |
|-------------|------------------------------|-------------|

4. b. False valve is closed tight  
 5. To verify that the supply 6. b. 22.28 ft<sup>3</sup> (801.5 L)

### Self-Test 2

1. a. True 4. b. False 7. b. 100 ft  
 2. b. False 5. c. 2 psi  
 3. b. False 6. c. 1" NPS

## Competency B4

### Self-Test 1

1. b. Exfiltration 3. b. 5 Pa (.02" wc) air systems  
 2. a. True 4. b. Direct vent and room 5. b. False

### Self-Test 2

1. d. Manufacturer's literature 6. d. 47 in.<sup>2</sup> lower  
 2. c. 9 in.<sup>2</sup> 7. b. 9 in.<sup>2</sup> 13. c. 201 in.<sup>2</sup>  
 3. c. ½" 8. d. 35 000 mm<sup>2</sup> 14. b. 10 in.<sup>2</sup>  
 4. c. Loose building of sufficient volume 9. b. 14 in.<sup>2</sup> 15. c. 310 000 mm<sup>2</sup>  
 5. b. 10% or 10 in.<sup>2</sup> 10. c. 32 in.<sup>2</sup> 16. b. 67 in.<sup>2</sup>  
 11. None required 17. d. 240 in.<sup>2</sup>  
 12. b. 260 in.<sup>2</sup> upper and 18. c. 12 250 mm<sup>2</sup>

### Self-Test 3

1. b. False 4. d. 36 in. 7. b. False  
 2. c. 24 in. 5. b. False 8. a. True  
 3. b. 12 in. 6. d. 50 ft 9. b. 12 in.



---

## Versioning History

This page provides a record of edits and changes made to this book since its initial publication. Whenever edits or updates are made in the text, we provide a record and description of those changes here. If the change is minor, the version number increases by 0.01. If the edits involve substantial updates, the version number increases to the next full number. The files posted by this book always reflect the most recent version. If you find an error in this book, please fill out the [Report an Error](#) form.

Version	Date	Change	Details
1.00	May 6, 2025	Book published.	